

THE SCIENTIFIC JOURNAL  
**SIBERIAN HERALD**  
OF AGRICULTURAL SCIENCE

*SIBIRSKII VESTNIK SEL'SKOKHOZYAISTVENNOI NAUKI*

FOUNDERS: SIBERIAN FEDERAL SCIENTIFIC CENTRE OF AGRO-BIOTECHNOLOGIES OF THE RUSSIAN ACADEMY OF SCIENCES;  
SIBERIAN BRANCH OF THE RUSSIAN ACADEMY OF SCIENCES

ESTABLISHED IN 1971

12 ISSUES PER YEAR

**Volume 54, No 10 (311)**

DOI: 10.26898



**2024**  
**October**

The purpose of the journal is to promptly inform scientists and practitioners of agricultural production about the latest achievements of agricultural science. The "Siberian Herald of Agricultural Science" publishes original articles on fundamental and applied problems in the following areas: general agriculture and crop production; plant breeding, seed production and biotechnology; agrochemistry, soil science, plant protection and quarantine; fodder production; infectious diseases and animal immunology; private zootechnics, feeding, technology of feed preparation and production of livestock products; breeding, selection, genetics, and animal biotechnology; technologies, machinery and equipment for the agro-industrial complex.

**Editor-in-Chief** – Alexander S. Donchenko, Academician of the Russian Academy of Sciences, Doctor of Science in Veterinary Medicine, Head Researcher, Head of the Institute of Experimental Veterinary Science of Siberia and the Far East of the Siberian Federal Scientific Centre of Agro-BioTechnologies of the Russian Academy of Sciences, Novosibirsk, Russia

**Deputy Editor-in-Chief** – Tatyana A. Lombanina, Head of the «Agronauka» Publishing House of the Siberian Federal Scientific Centre of Agro-BioTechnologies of the Russian Academy of Sciences, Novosibirsk, Russia

**Editorial board:**

Vladimir V. Azarenko Dr. Sci. in Engineering, Cor. Mem. of the Nat. Acad. Sci. of Belarus, Minsk, Belarus  
Victor V. Alt Acad. of Russ. Acad. Sci., Dr. Sci. in Engineering, Novosibirsk, Russia  
Olga S. Afanasenko Acad. of Russ. Acad. Sci., Dr. Sci. in Biology, Saint-Petersburg, Russia  
Gennady P. Gamzikov Acad. of Russ. Acad. Sci., Dr. Sci. in Biology, Novosibirsk, Russia  
Kirill S. Golokhvast Cor. Mem. of Russ. Acad. Edu., Dr. Sci. in Biology, Novosibirsk, Russia  
Nikolay P. Goncharov Acad. of Russ. Acad. Sci., Dr. Sci. in Biology, Novosibirsk, Russia  
Mikhail I. Gulyukin Acad. of Russ. Acad. Sci., Dr. Sci. in Veterinary Medicine, Moscow, Russia  
Valery N. Delyagin Dr. Sci. in Engineering, Novosibirsk, Russia  
Seyed Ali Johari Associate Professor, PhD, Sanandaj, Iran  
Irina M. Donnik Acad. of Russ. Acad. Sci., Dr. Sci. in Biology, Moscow, Russia  
Asankadyr T. Zhunushov Dr. Sci. in Veterinary Medicine, Acad. of the Nat. Acad. Sci. Rep. of Kyrgyzstan, Bishkek, Kyrgyzstan  
Nikolay M. Ivanov Cor. Mem. of Russ. Acad. Sci., Dr. Sci. in Engineering, Novosibirsk, Russia  
Andrey Yu. Izmailov Acad. of Russ. Acad. Sci., Dr. Sci. in Engineering, Moscow, Russia  
Nikolay I. Kashevarov Acad. of Russ. Acad. Sci., Dr. Sci. in Agriculture, Novosibirsk, Russia  
Valery I. Kiryushin Acad. of Russ. Acad. Sci., Dr. Sci. in Biology, Moscow, Russia  
Akhyzbek K. Kurishbaev Dr. Sci. in Agriculture, Acad. of Nat. Acad. Sci. Rep. of Kazakhstan, For. Mem. of the Russ. Acad. Sci., Alma-Ata, Kazakhstan  
Sergey N. Mager Dr. Sci. in Biology, Novosibirsk, Russia  
Muhammad A. Nawaz Professor, PhD, Tomsk, Russia  
Askar M. Nametov Dr. Sci. in Veterinary Medicine, Cor. Mem. of the Nat. Acad. Sci. Rep. of Kazakhstan, Uralsk, Kazakhstan  
Vasil S. Nikolov Dr. Sci. in Veterinary Medicine, Sofia, Bulgaria  
Sergey P. Ozornin Dr. Sci. in Engineering, Chita, Russia  
Valery L. Petukhov Dr. Sci. in Biology, Novosibirsk, Russia  
Revmira I. Polyudina Dr. Sci. in Agriculture, Novosibirsk, Russia  
Marina I. Selionova Dr. Sci. in Biology, Moscow, Russia  
Vladimir A. Soloshenko Acad. of Russ. Acad. Sci., Dr. Sci. in Agriculture, Novosibirsk, Russia  
Nikolay A. Surin Acad. of Russ. Acad. Sci., Dr. Sci. in Agriculture, Krasnoyarsk, Russia  
Aristidis M. Tsatsakis Dr. Sci. in Biology, For. Mem. of the Russ. Acad. Sci., Crete, Greece  
Alexander A. Shpedt Dr. Sci. in Agriculture, Krasnoyarsk, Russia  
Sezai Ercisli Professor, PhD, Erzurum, Turkey  
Seung H. Yang Professor, PhD, Gwangju, Korea

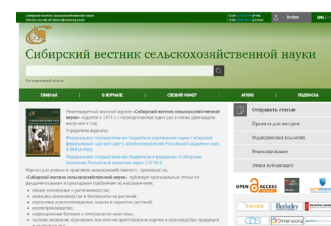

[www.sibvest.elpub.ru](http://www.sibvest.elpub.ru)

Editors *Galina N. Yagupova, Elena V. Mosunova, Evgeniya M. Isaevich. Corrector Valentina E. Selyanina.*

Desktop Publisher *Natalya Yu. Borisko. Translator Marina Sh. Gatsenko.*

Certificate PI FS77-64832 issued by the Federal Service for Supervision of Media, Communications and Information Technologies on February 2, 2016

**Publisher: Siberian Federal Scientific Centre of Agro-BioTechnologies of the Russian Academy of Sciences**

**Editorial and publisher's address: PO Box 463, office 456, SFSCA RAS Building, Krasnoobsk, Novosibirsk District, Novosibirsk Region, 630501, Russia.**

**Printing house address: room 156, SRI of Fodder Crops building, Krasnoobsk, Novosibirsk district, Novosibirsk region, 630501, Russia.**

**Tel/fax: +7-383-348-37-62; e-mail: sibvestnik@sfsc.ru; https://sibvest.elpub.ru**

Published on 11/20/2024. Format 60 × 84<sup>1</sup>/<sub>4</sub>. Paper type. No. 1. Offset printing. Printer's sheet 19,25

Publisher's signature 19,25. Circulation 500 copies. The price is free.

Printed at the Siberian Federal Scientific Centre of Agro-BioTechnologies of the Russian Academy of Sciences

© Siberian Federal Scientific Centre of Agro-BioTechnologies of the Russian Academy of Sciences, 2024

© Siberian Branch of the Russian Academy of Sciences, 2024



СОДЕРЖАНИЕ

CONTENTS

ЗЕМЛЕДЕЛИЕ И ХИМИЗАЦИЯ

AGRICULTURE  
AND CHEMICALIZATION

**Фёдоров Ю.И., Павлидис В.Д.** Пограничные случаи модели сорбции паров воды почвами с функцией источника-стока

**5 Fedorov Yu.I., Pavlidis V.D.** Border-line cases of the water vapor sorption model of the soils with source-drainage function

**Алтаев А.А., Билтуев А.С., Уланов А.К.** Плодородие степных почв Республики Хакасия

**13 Altaev A.A., Biltuev A.S., Ulanov A.K.** Fertility of steppe soils of the Republic of Khakassia

РАСТЕНИЕВОДСТВО И СЕЛЕКЦИЯ

PLANT GROWING AND BREEDING

**Базанов Т.А., Ущачповский И.В., Логинова Н.Н., Минина Е.В., Вересова П.Д.** Динамика экспрессии генов десатуразы в процессе формирования семян масличного льна

**25 Bazanov T.A., Ushchapovsky I.V., Loginova N.N., Minina E.V., Veresova P.D.** Dynamics of desaturase gene expression in the process of oil flax seed formation

- Родин К.А., Небезина А.Б.** Засоренность посевов риса, возделываемого по разным предшественникам при периодических поливах в условиях Нижнего Поволжья **40**
- Rodin K.A., Nevezhina A.B.** Weediness of rice crops cultivated on different forecrops under periodic irrigation in the Lower Volga region conditions
- Антимонова О.Н., Антимонов А.К.** Влияние гидротермических условий на содержание белка и незаменимых аминокислот в пшене проса посевного в лесостепи Самарской области **48**
- Antimonova O.N., Antimonov A.K.** Influence of hydrothermal conditions on the content of protein and essential amino acids in common millet in the forest-steppe of the Samara region
- Ожерельева З.Е., Прудников П.С., Ступина А.Ю., Болгова А.О.** Изучение влияния органоминерального удобрения на устойчивость яблони к весенним заморозкам **58**
- Ozherelieva Z.E., Prudnikov P.S., Stupina A.Yu., Bolgova A.O.** Study of the effect of organomineral fertilizer on the resistance of apple trees to spring frosts

*ЗАЩИТА РАСТЕНИЙ*

*PLANT PROTECTION*

- Асатурова А.М., Жевнова Н.А., Сидоров Н.М., Кремнева О.Ю.** Эффективность бактерий-антагонистов *Bacillus* и *Pseudomonas* в качестве агентов биоконтроля сетчатой пятнистости озимого ячменя в полевых условиях **69**
- Asaturova A.M., Zhevnova N.A., Sidorov N.M., Kremneva O.Yu.** Efficacy of *Bacillus* and *Pseudomonas* antagonist bacteria as biocontrol agents of barley net blotch in field conditions

*ЗООТЕХНИКА И ВЕТЕРИНАРИЯ*

*ZOOTECHNICS  
AND VETERINARY MEDICINE*

- Попов П.А., Осипова И.С.** Мониторинг коагулазоотрицательных стафилококков, выделенных из сборного молока в неблагополучных по маститу коров хозяйствах **78**
- Popov P.A., Osipova I.S.** Monitoring of coagulase-negative staphylococci isolated from the bulk milk in the farms troubled by cow mastitis
- Власенко В.С., Борисов Е.С., Новикова Н.Н.** Эпизоотическая ситуация по лейкозу крупного рогатого скота в Омской области и краткосрочный прогноз ее развития **85**
- Vlasenko V.S., Borisov E.S., Novikova N.N.** Epizootic situation on bovine leukosis in the Omsk region and a short-term forecast of its development

- Юматов Е.Н., Евлагина Е.Г., Евлагин В.Г., Лейнвебер Е.Ф.** Сравнительная оценка производственных платформ для получения вакцин на основе куриных яиц и биотехнологий тутового шелкопряда **93** **Yumatov E.N., Evlagina E.G., Evlagin V.G., Leinweber E.F.** Comparative evaluation of production platforms for chicken egg-based vaccines and mulberry silkworm biotechnology
- Лукьянчикова Н.Л., Цимбалова Т.А., Андреева И.В., Шаталова Е.И., Рогачев В.А.** Мука из насекомых как альтернативный кормовой ингредиент в рационе сельскохозяйственных животных **108** **Lukyanchikova N.L., Tsimbalova T.A., Andreeva I.V., Shatalova E.I., Rogachev V.A.** Insect meal as an alternative feed ingredient in the diet of farm animals
- Лопсан Ч.О.** Особенности проявления лейкоза крупного рогатого скота на территории Республики Тыва **118** **Lopsan Ch.O.** Features of bovine leukosis manifestation on the territory of the Republic of Tuva

*МЕХАНИЗАЦИЯ, АВТОМАТИЗАЦИЯ,  
МОДЕЛИРОВАНИЕ И  
ИНФОРМАЦИОННОЕ ОБЕСПЕЧЕНИЕ*

*MECHANISATION, AUTOMATION,  
MODELLING AND DATAWARE*

- Минеев В.В., Ёлкин О.В., Алейников А.Ф., Морозов В.Б., Рихтер В.А.** Разработка устройства для диагностики пятнистостей земляники садовой **128** **Mineev V.V., Yolkin O.V., Aleynikov A.F., Morozov V.B., Richter V.A.** Development of a device for diagnostics of garden strawberry spot diseases

*НАУЧНЫЕ СВЯЗИ*

*SCIENTIFIC RELATIONS*

- Прудников В.А., Степанова Н.В., Фесько Д.Ю.** Влияние органического вещества дерново-подзолистой почвы на урожайность и качество льнопродукции **141** **Prudnikov V.A., Stepanova N.V., Fesko D.Yu.** Influence of organic matter of sod-podzolic soil on the yield and quality of flax products



<https://doi.org/10.26898/0370-8799-2024-10-1>

УДК: 631.4:004.492

Тип статьи: оригинальная

Type of article: original

## Пограничные случаи модели сорбции паров воды почвами с функцией источника-стока

✉ Фёдоров Ю.И., Павлидис В.Д.

*Оренбургский государственный аграрный университет, Институт управления рисками и комплексной безопасности*

Оренбург, Россия

✉ e-mail: yurf0023@mail.ru

Для разработанной авторами неклассической математической модели процесса сорбции водяных паров поверхностью почвы с источником-стоком дан теоретический анализ влияния источника-стока на динамику сорбционного процесса для одного частного (пограничного) случая. В отличие от модели М. Гризмера, в которой уравнение сорбции однородное, в предложенной модели уравнение сорбции неоднородное – присутствует постоянный ненулевой свободный член, который рассматривается как параметр внешнего воздействия на систему (функция источника-стока). Параметр позволяет управлять сорбционным процессом, изменяя его характеристики. Решение модельного уравнения определяет основное аналитическое соотношение для анализа динамики объемной влажности почвы как функции времени. Поведение функции объемной влажности определяется влиянием выбранного значения параметра, а также соотношением между постоянной начальной и равновесной влажностью, для которого возможны три варианта. В результате исследования динамики объемной влажности почвенной системы согласно разработанной модели установлено, что в этом случае сорбционный процесс будет протекать в трех режимах: первый режим моделируемого процесса – это ограниченный по времени конечный процесс критического иссушения почвы; второй режим – это стационарный процесс, когда объемная влажность почвы с течением времени не меняется и остается равной начальной влажности (процесс асимптотически вырождается); в третьем случае рассматриваемая сорбционная модель описывает неограниченный во времени асимптотический процесс падения объемной влажности почвы от начального значения до предельного (ненулевого) значения.

**Ключевые слова:** математическая модель, динамика сорбции паров воды почвами, источник-сток

## Border-line cases of the water vapor sorption model of the soils with source-drainage function

✉ Fedorov Yu.I., Pavlidis V.D.

*Orenburg State Agrarian University, Institute of Risk Management and Integrated Security*

Orenburg, Russia

✉ e-mail: yurf0023@mail.ru

A theoretical analysis of the influence of the source-drain on the dynamics of the sorption process for one particular (border-line) case is given for the non-classical mathematical model of the process of water vapor sorption by the soil surface with a source-drain developed by the authors. Unlike the model of M. Griesmer, in which the sorption equation is homogeneous, in the proposed model the sorption equation is heterogeneous – there is a constant non-zero free term, which is considered as a parameter of external influence on the system (source-drain function). The parameter allows controlling the sorption process by changing its characteristics. The solution of the model equation determines the basic analytical relationship for analyzing the dynamics of soil volumetric water content as a

function of time. The behavior of the volumetric water content function is determined by the influence of the selected parameter value as well as by the relationship between constant initial and equilibrium moisture, for which three variants are possible. As a result of studying the dynamics of soil system volumetric moisture according to the developed model, it has been established that in this case the sorption process will proceed in three modes: the first mode of the modeled process is a time-limited, finite process of critical soil drying; the second mode is a stationary process, when soil volumetric water content does not change over time and remains equal to the initial moisture (the process asymptotically degenerates); in the third case, the considered sorption model describes a time-unlimited asymptotic process of soil volumetric water content fall from the initial value to the limiting (non-zero) value.

**Keywords:** mathematical model, dynamics of water vapor sorption by soils, source-drainage

**Для цитирования:** Фёдоров Ю.И., Павлидис В.Д. Пограничные случаи модели сорбции паров воды почвами с функцией источника-стока // Сибирский вестник сельскохозяйственной науки. 2024. Т. 54. № 10. С. 5–12. <https://doi.org/10.26898/0370-8799-2024-10-1>

**For citation:** Fedorov Yu.I., Pavlidis V.D. Border-line cases of the water vapor sorption model of the soils with source-drainage function. *Sibirskii vestnik sel'skokhozyaistvennoi nauki = Siberian Herald of Agricultural Science*, 2024, vol. 54, no. 10, pp. 5–12. <https://doi.org/10.26898/0370-8799-2024-10-1>

**Конфликт интересов**

Авторы заявляют об отсутствии конфликта интересов.

**Conflict of interest**

The authors declare no conflict of interest.

## INTRODUCTION

The problem of quantitative description of the processes of absorption and evaporation of gases and vapors by the soil surface is one of the most important in modern agrosoil science and agroecology. The need for research in this direction is associated with the tasks of agrophysical and ecological assessment of soil fertility, preservation of its physical fertility. Physical fertility of soils and productivity of agricultural crops largely depend on the state of soil air. The key component of soil air is water vapors. Optimal air and moisture content in soil promotes the growth of plant crops and microorganisms, the activity of two main ecological functions of soil – photosynthesis and decomposition of organic matter<sup>1</sup>. In addition, modern science has formed an idea of the role of soil in the global

regulation of the gas regime of the planet's atmosphere as the main ecological gas function, in connection with which the importance of research into the processes of sorption of gases and vapors by the soil surface within the framework of environmental safety of agricultural production has increased<sup>2,3</sup> [1, 2].

Due to the important role of the processes in the gas phase of the soil system for agrosoil science and agroecology, many studies have been devoted to the study of the problems in this area. Bibliography on the studies of soil gas sorption is given in the works<sup>4</sup> [2], on water vapor adsorption by soils – in the works (see footnote 3)<sup>5-7</sup> [3-8]. Some aspects of the dynamics of gas and vapor sorption were considered earlier in the paper [9].

The purpose of the research is to quantify the influence of the source-drainage factor

<sup>1</sup>Kudeyarov V.N., Khakimov F.I., Deeva N.F. et al. Assessment of soil respiration in Russia // *Eurasian Soil Science*, 1995, N 1, pp. 33–42.

<sup>2</sup>Zavarzin G.A. Interaction of geosphere and biosphere // *Ecology and Soils*, Pushchino, 1998, pp. 139–153.

<sup>3</sup>Kapinos V.A., Tonkikh A.P. Determination of the total isotherm of water vapor by soils // *Eurasian Soil Science*, 1986, N 10, pp. 107–113.

<sup>4</sup>Brunauer S., Emmet P.H., Teller E. Adsorption of gases in multimolecular layers // *J. Amer. Chem. Soc.*, 1938, vol. 60, pp. 309–319.

<sup>5</sup>Zuev V.S. To the method of measuring and calculating the parameters of the BET equation for water vapor sorption // *Scientific and Technical Bulletin on Agronomic Physics*, 1986, N 69, pp. 54–58.

<sup>6</sup>Pachepsky Ya.A. Mathematical models of processes in ameliorated soils. Moscow: Publishing house of the Moscow State University, 1992, 85 p.

<sup>7</sup>Grismer M.E. Kinetics of water vapor adsorption on soils // *Soil Sci.*, 1987, vol. 143, N 5, pp. 367–371. Available from: Mark E Grismer Retrieved on: 23 June 2015. Printed in U.S.A.

on the sorption process of water vapor by soil within the context of the author's non-classical mathematical model of water vapor sorption by source-sink soils.

The main task is to study the influence of the source- sink function in the sorption model on the dynamics of soil system volumetric moisture for one particular (border-line) case of the model under study, which is defined by the mathematical relations specified in the paper.

## MATERIAL AND METHODS

This paper studies the dynamics of water vapor adsorption (desorption) by soil surface in the author's mathematical model with source-sink function. In the paper [9], we proposed a non-classical mathematical model of the dynamics of water vapor adsorption by soils with a source- sink function in the form of a problem with initial conditions for an inhomogeneous nonlinear differential equation with a stationary free term  $f$  as a source- sink function, which is a parameter of the sorption process:

$$\theta'(t) = k \left( 1 - \frac{\theta}{\theta_p} \right) + f, \theta(0) = \theta_0, \quad (1)$$

where  $\theta'(t)$  – volumetric soil moisture at the moment of time  $t$ ,  $\theta_p$  – constant equilibrium humidity (as a system factor determining the constraints on the dynamics of volumetric humidity),  $k$  – model constant, adsorption rate parameter,  $\theta_0$  – constant initial moisture.

This model is a development, generalization of the water vapor sorption model proposed by Professor M. Grizmer of the University of California (see footnote 7). In contrast to the Grizmer model, in which the sorption equation is homogeneous, in our proposed model the sorption equation is inhomogeneous – there is a constant non-zero free term  $f$ , which influences the sorption process and is considered as a parameter of the modeled process (source- sink function). The parameter  $f$  allows to control the sorption process by changing its characteristics (by changing the values of parameters  $\theta_0$  and  $f$ ), which, in our opinion, expands the possibilities of modeling of sorption processes.

We have obtained an analytical solution of the problem (1). Having represented equation (1) in the standard form for the theory of differential equations, let us write the problem (1) in the form

$$\theta'(t) - k\theta + \frac{k}{\theta_p}\theta^2 = f, \theta(0) = \theta_0, \quad (2)$$

Equation (2) is an inhomogeneous Riccati equation with constant coefficients and a stationary free term. The Riccati equation in general case is not reducible to quadrature. However, the condition of constancy of the coefficients and the parameter  $f$  of the equation (2) makes it possible to reintegrate it in finite form. The classical equation of water vapor sorption is usually integrated by separation of the variables. We propose the following efficient apparatus for integration of the equation (2).

After replacing the unknown function  $\theta(t)$  in the equation (2)

$$\theta(t) = \frac{\theta_p}{k} \frac{z'}{z}, \quad (3)$$

problem (2) is reduced to the Cauchy problem for a linear homogeneous differential equation of the second order with constant coefficients

$$\begin{aligned} z'' - kz' - f \frac{k}{\theta_p} z &= 0, \\ z(0) = 1, z'(0) &= k \frac{\theta_0}{\theta_p}. \end{aligned} \quad (4)$$

The general solution of the equation (4) is found in accordance with the general theory of such equations and is a linear combination of solutions of the fundamental system  $z_1(t)$  and  $z_2(t)$ :

$$z(t) = C_1 z_1(t) + C_2 z_2(t), \quad (5)$$

where  $C_1$  and  $C_2$  – arbitrary constants. The choice of the fundamental system of solutions is determined by the sign of the discriminant  $D$  of the characteristic polynomial of the equation (4), its roots  $\lambda_1$  and  $\lambda_2$ :

$$D = k^2 + \frac{4kf}{\theta_p} = k^2 \left( 1 + \frac{4f}{k\theta_p} \right),$$

$$\begin{aligned} \lambda_1 &= \frac{k}{2} \left( 1 - \sqrt{1 + \frac{4f}{k\theta_p}} \right), \\ \lambda_2 &= \frac{k}{2} \left( 1 + \sqrt{1 + \frac{4f}{k\theta_p}} \right). \end{aligned} \quad (6)$$

The solution of the Cauchy problem (4) is found by the formula (5), in which  $C_1$  and  $C_2$  are the numbers found using the initial values (4) from the system of equations

$$\begin{cases} C_1 z_1(0) + C_2 z_2(0) = 1, \\ C_1 z_1'(0) + C_2 z_2'(0) = k \frac{\theta_0}{\theta_p}. \end{cases} \quad (7)$$

In the work [9] we have shown that depending on the interval to which the values of the model parameter  $f$  belong, which in turn is determined by the sign of the discriminant  $D$ , the found solution  $z(t)$  will be represented by three different formulas at  $D > 0$ ,  $D = 0$ ,  $D < 0$ . Here we study in detail the behavior of the modeled process at  $D = 0$ .

At  $D = 0$ , relations (6) for the discriminant, roots of the characteristic polynomial and the solution of the problem (4) will take the form

$$D = 0, \text{ i.e., } f = -\frac{k\theta_p}{4}, \lambda_1 = \lambda_2 = \frac{k}{2}, \quad (8)$$

$$z(t) = \exp\left(\frac{k}{2}t\right) + k \left( \frac{\theta_0}{\theta_p} - \frac{1}{2} \right) t \exp\left(\frac{k}{2}t\right). \quad (9)$$

Substituting (9) into (3), we find the solution  $\theta(t)$  of the problem (1)

$$\theta(t) = \frac{\theta_p}{2} \frac{2\theta_0 - k \left( \frac{\theta_p}{2} - \theta_0 \right) t}{\theta_p - k \left( \frac{\theta_p}{2} - \theta_0 \right) t}. \quad (10)$$

Formula (10) is the basic analytical relation for analyzing the dynamics of the key characteristic of the considered sorption process – volumetric soil moisture  $\theta(t)$  at time  $t$ .

## RESULTS AND DISCUSSION

In this paper we have evaluated the dynamics of soil volumetric moisture  $\theta(t)$  for a special case of the mathematical model of water vapor sorption by source- sink soils, when the value

of the parameter  $f$  is determined by the relation (8), i.e. at  $D=0$ . Using the found formula (10) for the volumetric moisture content  $\theta(t)$  of the soil system the dynamics was analyzed  $\theta(t)$ . The behavior of  $\theta(t)$  is determined by the influence of the chosen value (8) of the parameter  $f$ , and also the relation between  $\theta_0$  and  $\frac{\theta_p}{2}$ ,

which has three possible variants:

$$0 < \theta_0 < \frac{\theta_p}{2}, \quad \theta_0 = \frac{\theta_p}{2}, \quad \frac{\theta_p}{2} < \theta_0 \leq \theta_p.$$

Here are the results of this analysis:

1).  $0 < \theta_0 < \frac{\theta_p}{2}$ . Since the character of the sorption curve (10) will be determined by the relationship between  $\theta_0$  and  $\frac{\theta_p}{2}$ , then it is convenient to introduce a coefficient, characterizing this ratio

$$r = \theta_0 / \frac{\theta_p}{2} = \frac{2\theta_0}{\theta_p}. \quad (11)$$

As,  $0 < \theta_0 < \frac{\theta_p}{2}$  then  $0 < r < 1$ . Therefore, in the case under consideration it will be

$$\theta_0 = r \frac{\theta_p}{2}, \quad 0 < r < 1. \quad (12)$$

Let's substitute in formula (10) instead of  $\theta_0$  its expressions from (12) and bring it to the form

$$\theta(t) = \frac{\theta_p}{2} \frac{2r - k(1-r)t}{2 - k(1-r)t}, \quad 0 < r < 1. \quad (13)$$

Decomposing the fractional linear function (13) into the sum of the integer part and the proper fraction

$$\theta(t) = \frac{\theta_p}{2} \left( \frac{2-2r}{k(1-r)} \frac{1}{(t-2/k(1-r))} + 1 \right),$$

we conclude that the graph of the function  $\theta(t)$  (13) is a hyperbola with horizontal and vertical asymptotes

$$0 = \frac{\theta_p}{2} \text{ and } t = \frac{2}{k(1-r)}, \text{ i.e. } \left( t = \frac{\theta_p}{2} \frac{4}{k(\theta_p - 2\theta_0)} \right)$$

respectively. But it is possible to interpret function (13) as the volumetric soil moisture  $\theta(t)$  in the considered sorption process only in the time interval from the beginning of the process to the moment when the function  $\theta(t)$  turns to zero, i.e. in the interval  $[0; t_{кр}]$

$$t_{кр} = \frac{4\theta_0}{k(\theta_p - 2\theta_0)}. \quad (14)$$

By the  $t_{кр}$  time point, the soil of the agro-landscape is critically dried out.

The paper by M. Grizmer (see footnote 7) describes the results of the kinetic experiments on the study of various characteristics of water vapor adsorption by fine-grained soils. Taking the values of key parameters from Grizmer's experiments on water vapor adsorption by Volclay's bentonite, we give the form of the function  $\theta(t)$  (13) of soil volumetric moisture in our model and the adsorption curves at different  $r$ :

$$\theta_p = 0,2184, \frac{\theta_p}{2} = 0,1092, k = 1,02,$$

$$\theta(t) = 0,1092 \frac{2r - 1,02(1-r)t}{2 - 1,02(1-r)t}, \quad 0 < r < 1. \quad (15)$$

Function graph (15) at  $r = 0,78$ , i. e. at  $\theta_0 = 0,78 \frac{\theta_p}{2}$ , is shown in Fig. 1, with  $t_{кр} = 6,952$  (min). The solid line shows a part of the graph of the function (15) on the time interval  $[0; t_{кр}]$ , which, in fact, is interpreted as a sorption curve

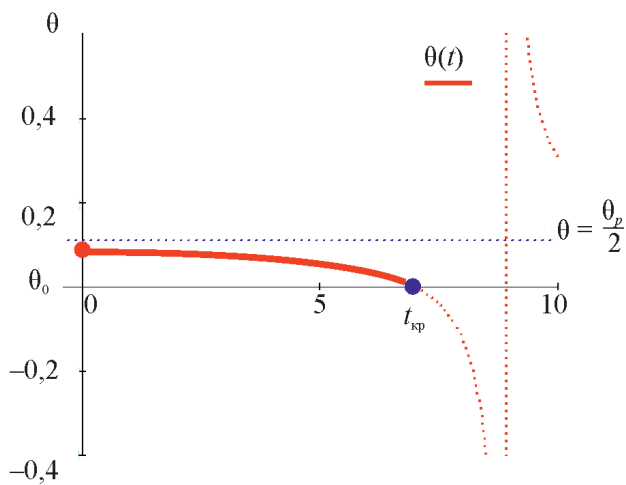

**Рис. 1.** График функции  $\theta(t)$ :  $\theta_0 = 0,78 \frac{\theta_p}{2}, r = 0,78$

**Fig. 1.** Function graph  $\theta(t)$ :  $\theta_0 = 0,78 \frac{\theta_p}{2}, r = 0,78$

describing the sorption process under consideration. The function  $\theta(t)$  on the interval  $[0; t_{кр}]$  is convex upward, monotonically decreasing from  $\theta_0$  to  $\theta(t_{кр}) = 0$ . The parts of the graph in Fig. 1 depicted by the dashed line have no physical meaning in the model under consideration. The process turns into a time-limited, finite process of critical drying of soil.

Sorption curves in the considered case ( $0 < \theta_0 < \frac{\theta_p}{2}$ ) at different  $r$ ,  $0 < r < 1$ , are shown in Fig. 2.

At values of  $\theta_0$  much less than  $\theta_0/2$ , the duration of the  $t_{кр}$  time interval before critical soil drying is extremely short, with  $t_{кр} \rightarrow 0$  at  $\theta_0 \rightarrow 0$ : a fast-flowing process of soil dehydration occurs.

For example, at  $r = 0,2$ , i.e. at  $\theta_0 = 0,2 \frac{\theta_p}{2}$ ,  $t_{кр}$  time = 0,49 (min), and at  $\theta_0 = 0,78 \frac{\theta_p}{2}$   $t_{кр} = 6,952$  (min). When increasing constant initial moisture content  $\theta_0$  from  $\theta_0 = 0$   $\theta_0 = \frac{\theta_p}{2}$  to (in the case of  $0 < \theta_0 < \frac{\theta_p}{2}$ ) the value  $t_{кр}$  will increase indefinitely, and  $t_{кр} \rightarrow +\infty$  at  $\theta_0 \rightarrow \frac{\theta_p}{2} - 0$  – the process of soil dehydration process becomes longer, protracted, but final. For example, at  $r = 0,995$ , i.e. at  $\theta_0 = 0,995 \frac{\theta_p}{2}$ ,  $t_{кр} = 390,196$  (min).

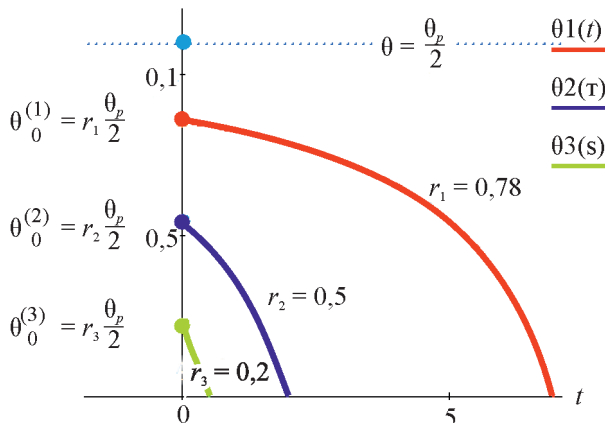

**Рис. 2.** График функции  $\theta(t)$ :  $0 < \theta_0 < \frac{\theta_p}{2}, 0 < r < 1$

**Fig. 2.** Function graph  $\theta(t)$ :  $0 < \theta_0 < \frac{\theta_p}{2}, 0 < r < 1$

Thus, the modeled process in the first case ( $0 < \theta_0 < \frac{\theta_p}{2}$ ) – is a time-limited, finite process of critical soil desiccation.

In the second case  $\theta_0 = \theta_0 = \frac{\theta_p}{2}$ , i.e.  $2\theta_0 = \theta_p$ . The process is becoming stationary because the soil volumetric moisture does not change with time and remains equal to the initial moisture content  $\theta_0$ :

$\theta(t) = \theta_0 = \frac{\theta_p}{2}$ . The process is asymptotically degenerate since the adsorption line in this case coincides with the horizontal asymptote of the adsorption curves at  $\theta_0 < \frac{\theta_p}{2}$  and  $\theta_0 > \theta_0 = \frac{\theta_p}{2}$ .

In the third case  $\frac{\theta_p}{2} < \theta_0 \leq \theta_p$ . As in the first case, the relationship between  $\theta_0$  and  $\frac{\theta_p}{2}$ , we will characterize by the coefficient  $r$  in the formula (11), the range of which will change:

$$\theta_0 = r \frac{\theta_p}{2}, 1 < r \leq 2. \quad (16)$$

The formula of volumetric moisture content  $\theta(t)$  of the soil system (as in the first case) we will assume in the form (13), but taking into account the new range  $1 < r < 2$ :

$$\theta(t) = \frac{\theta_p}{2} \frac{2r - k(1-r)t}{2 - k(1-r)t}, 1 < r < 2. \quad (17)$$

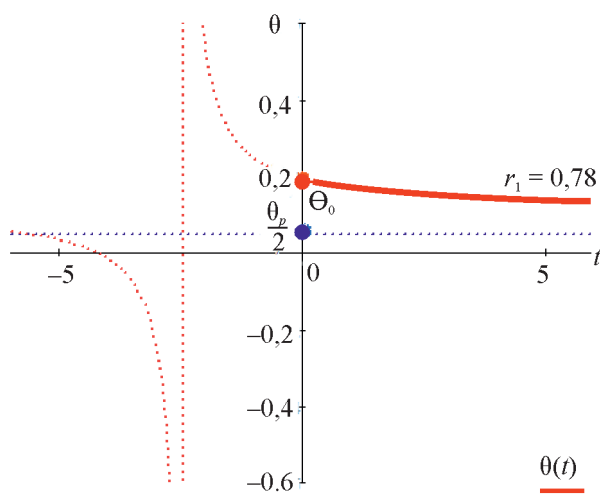

**Рис. 3.** График функции  $\theta(t)$ :  $\frac{\theta_p}{2} < \theta_0 \leq \theta_p, r = 1,8$

**Fig. 3.** Function graph  $\theta(t)$ :  $\frac{\theta_p}{2} < \theta_0 \leq \theta_p, r = 1,8$

The function  $\theta(t)$  (17) is determined on the time interval  $t \in [0; +\infty)$ , convex downward, monotonically decreases from the initial value  $\theta_0$  asymptotically tending to  $\frac{\theta_p}{2}$  at  $t \rightarrow +\infty$ .

The sorption model in this case describes a time-unlimited asymptotic process of soil volumetric moisture content  $\theta(t)$  falling from the value  $\theta_0$  to the limit value (non-zero) value  $\frac{\theta_p}{2}$ .

The function  $\theta(t)$  (17) with the parameters taken from the work of M. Grizmer (see footnote 7) ( $\theta_p = 0,2184, \frac{\theta_p}{2} = 0,1092, k = 1,02$ ), has the form of

$$\theta(t) = 0,1092 \frac{2r - 1,02(1-r)t}{2 - 1,02(1-r)t}, 1 < r \leq 2. \quad (18)$$

Fig. 3 shows the graph of the function (18) at  $r = 1.8$ . The solid line represents one part of this graph, which describes the sorption process considered in the third case. The other part of the graph, depicted by the dashed line, has no physical meaning in the model under consideration.

Several adsorption curves in the considered

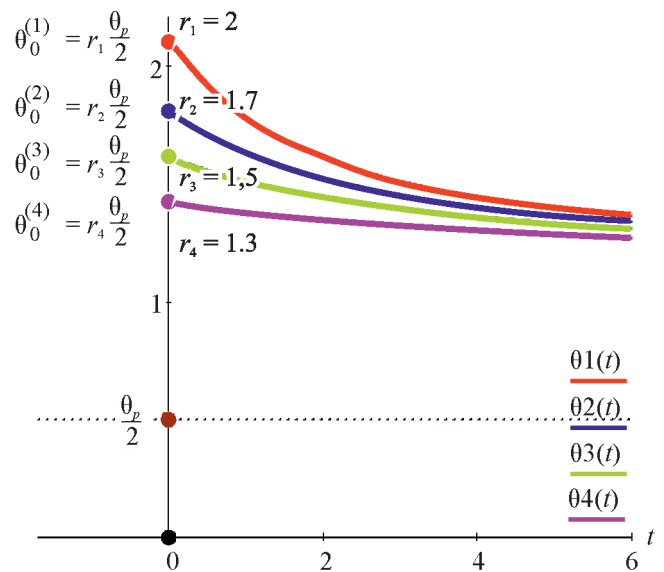

**Рис. 4.** График функции  $\theta(t)$ :  $\frac{\theta_p}{2} < \theta_0 \leq \theta_p, 1 < r \leq 2$

**Fig. 4.** Function graph  $\theta(t)$ :  $\frac{\theta_p}{2} < \theta_0 \leq \theta_p, 1 < r \leq 2$

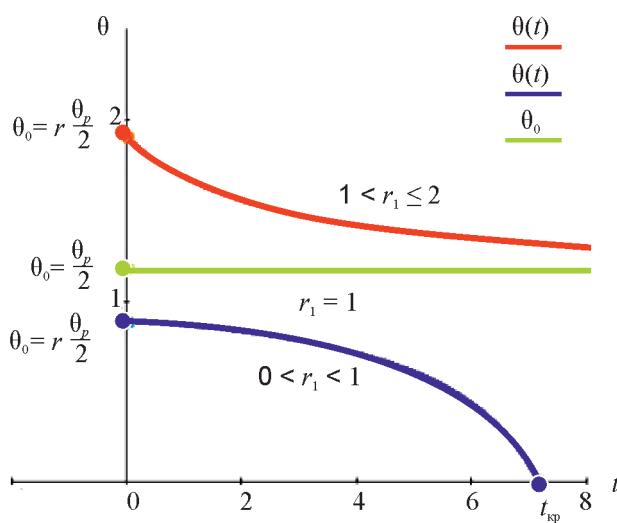

**Рис. 5.** График функции  $\theta(t)$ :  $0 < \theta_0 \leq \theta_p$ ,  $0 < r \leq 2$   
**Fig. 5.** Function graph  $\theta(t)$ :  $0 < \theta_0 \leq \theta_p$ ,  $0 < r \leq 2$

case ( $\frac{\theta_p}{2} < \theta_0 \leq \theta_p$ ) at different  $r$  in fig. 4 show the change in the dynamics of the volumetric moisture content  $\theta(t)$  depending on the  $r$ ,  $1 < r \leq 2$ . The limiting curve at  $r = 2$  bounds from above the whole family of the curves (18).

The process as a whole over the entire range  $0 < r \leq 2$  is characterized by the sorption lines from different  $r$  ranges of  $r$  in fig. 5.

## CONCLUSION

In the article for the author's mathematical model of the process of sorption of water vapor by the soil surface with a source-drain a detailed mathematical analysis of the dynamics of the sorption process in one of its special (special, transitional) cases, which is determined by the condition  $D = 0$ . In this case, the dynamics of the volumetric moisture content  $\theta(t)$  of the soil system is determined not only by the selected model parameters, but also by the relation between  $\theta_0$  and  $\frac{\theta_p}{2}$ , which has three variants are possible. Therefore, this analysis establishes that the sorption process of interaction between water vapor and soil solid phase will proceed in one of three possible regimes. In the first case ( $0 < \theta_0 < \frac{\theta_p}{2}$ ) the modeled process is a time-lim-

ited, finite process of critical soil desiccation; in the second case ( $\theta_0 = \frac{\theta_p}{2}$ ) the process is stationary, soil volumetric moisture does not change with time and remains equal to initial moisture (the process asymptotically degenerates); in the third case ( $\frac{\theta_p}{2} < \theta_0 \leq \theta_p$ ) the sorption model describes a time-unlimited asymptotic process of soil volumetric moisture  $\theta(t)$  falling from the initial value  $\theta_0$  to the limit value.

The results of the conducted studies expand the knowledge about the considered processes and can be applied for further studies of moisture dynamics in the profile of ameliorated and texture-differentiated soils.

## СПИСОК ЛИТЕРАТУРЫ

1. Ковалев И.В., Ковалева Н.О. Экологические функции почв и вызовы современности // Экологический вестник Северного Кавказа. 2020. Т. 16. № 2. С. 4–16.
2. Смагин А.В. Газовая функция почв // Почвоведение. 2000. № 10. С. 1211–1223.
3. Моисеев К.Г., Терлеев В.В. Применение фрактального моделирования в гидрофизике почв // Таврический вестник аграрной науки. 2022. № 3 (31). С. 126–137.
4. Моисеев К.Г., Терлеев В.В. Влияние увеличения количества осадков на структуру почвенного покрова и текстурные свойства почв // Агрофизика. 2019. № 4. С. 22–30. DOI: 10.25695/AGRPH.2019.04.04.
5. Моисеев К.Г. Определение удельной поверхности почв на основе величины гигроскопической влажности // Почвоведение. 2008. № 7. С. 845–849.
6. Харитонова Г.В., Витязев В.Г., Лапекина С.И. Математическая модель адсорбции паров воды почвами // Почвоведение. 2010. № 2. С. 196–205.
7. Харитонова Г.В., Шеин Е.В., Витязев В.Г., Лапекина С.И. Уравнение для описания полной изотермы адсорбции паров воды почвами // Вестник Московского университета. Сер. 17, Почвоведение. 2003. № 1. С. 8–14.
8. Харитонова Г.В., Витязев В.Г. Изотермы сорбции водяного пара почвами // Почвоведение. 2000. № 4. С. 446–453.

9. Федоров Ю.И., Павлидис В.Д., Чкалова М.В. Неклассическая кинетическая математическая модель адсорбции паров воды почвами // Агрофизика. 2023. № 1. С. 57–63. DOI: 10.25695/AGRPH.2023.01.08.

## REFERENCES

1. Kovalev I.V., Kovaleva N.O. Ecological functions of soils and new challenges. *Ekologicheskii vestnik Severnogo Kavkaza = The North Caucasus Ecological Herald*, 2020, vol. 16, no. 2, pp. 4–16. (In Russian).
2. Smagin A.V. The gas function of soils. *Pochvovedenie = Eurasian Soil Science*, 2000, no. 10, pp. 1211–1223. (In Russian).
3. Moiseev K.G., Terleev V.V. Application of fractal simulation in soil hydrophysics. *Tavrisheskii vestnik agrarnoi nauki = Taurida Herald of the Agrarian Sciences*, 2022, no. 3 (31), pp. 126–137. (In Russian).
4. Moiseev K.G., Terleev V.V. The impact of increased precipitation on the structure of soil and soil texture. *Agrofizika = Agrophysica*, 2019, no. 4, pp. 22–30. (In Russian). DOI: 10.25695/

AGRPH.2019.04.04.

5. Moiseev K.G. Determination of the specific soil surface area from the hygroscopic water content. *Pochvovedenie = Eurasian Soil Science*, 2008, no. 7, pp. 845–849. (In Russian).
6. Kharitonova G.V., Vityazev V.G., Lapekina S.I. A mathematical model for the adsorption of water vapor by soils. *Pochvovedenie = Eurasian Soil Science*, 2010, no. 2, pp. 196–205.
7. Kharitonova G.V., Shein E.V., Vityazev V.G., Lapekina S.I. Equation to describe complete isotherms of adsorption of water vapor by soils. *Vestnik Moskovskogo universiteta. Ser. 17, Pochvovedenie = Moscow University Bulletin. Series 17. Soil science*, 2003, no. 1, pp. 8–14. (In Russian).
8. Kharitonova G.V., Vityazev V.G. Isotherms of adsorption of water vapor by soils. *Pochvovedenie = Eurasian Soil Science*, 2000, no. 4, pp. 446–453. (In Russian).
9. Fedorov Yu.I., Pavlidis V.D., Chkalova M.V. Non-classical kinetic mathematical model of water vapor adsorption by soils. *Agrofizika = Agrophysica*, 2023, no. 1, pp. 57–63. (In Russian). DOI: 10.25695/AGRPH.2023.01.08.

## ИНФОРМАЦИЯ ОБ АВТОРАХ

✉ **Фёдоров Ю.И.**, кандидат физико-математических наук, доцент; **адрес для переписки:** Россия, 460014, Оренбург, ул. Челюскинцев, 18; e-mail: yurf0023@mail.ru

**Павлидис В.Д.**, кандидат физико-математических наук, профессор

## AUTHOR INFORMATION

✉ **Yuri I. Fedorov**, Candidate of Science in Physics and Mathematics, Associate Professor; **address:** 18, Chelyuskintsev St., Orenburg, 460014, Russia; e-mail: yurf0023@mail.ru

**Victoria D. Pavlidis**, Candidate of Science in Physics and Mathematics, Professor

Дата поступления статьи / Received by the editors 07.08.2024  
Дата принятия к публикации / Accepted for publication 02.10.2024  
Дата публикации / Published 20.11.2024

## Плодородие степных почв Республики Хакасия

✉ Алтаев А.А., Билтуев А.С., Уланов А.К.

*Бурятский научно-исследовательский институт сельского хозяйства – филиал Сибирского федерального научного центра агробиотехнологий Российской академии наук*

Улан-Удэ, Россия

✉ e-mail: burniish@inbox.ru

Проведено почвенно-геоботаническое обследование основных эрозионно-опасных сельскохозяйственных ландшафтов степной зоны Республики Хакасия путем закладки шести реперных участков на полигонах, выбранных методом дистанционного зондирования Земли. На основании морфологического описания разрезов выделены следующие виды почв: обыкновенный и южный чернозем, темно-каштановая и каштановая. Проективное покрытие чернозема обыкновенного составило 58%, южного – 35–66%, темно-каштановой почвы – 60%, каштановой – 40%. Растительный покров на пахотных почвах представлен культурной и сорной растительностью, на пастбищах – разнотравными ассоциациями с мелко- и крупнодерновинными растениями настоящих степей. Генетические горизонты изученных разрезов соответствуют типу почв. Плодородие почв очень низкое, обусловленное как факторами почвообразования, так и дигрессионными процессами природного и антропогенного характера. Близкое залегание карбонатов от поверхности (20–35 см) при малом количестве осадков и преобладании выпотного водного режима привело к подщелачиванию верхнего (0–20 см) слоя почвы. Среди поглощенных оснований преобладает кальций. Его содержание относительно концентрации магния в 2,5 и 5,5 раза выше на каштановых и черноземных почвах соответственно. Наиболее плодородные почвы, сформированные в наиболее увлажненной Ширинской степи, содержат до 3,3–3,4% органического вещества. В почвах более сухих степей в южной части республики наблюдается снижение содержания органического вещества до 2,1–2,9%. В соответствии с содержанием органического вещества изменялась и концентрация общего азота в пределах 0,17–0,29 мг/кг. Отмечены средняя и высокая степени биогенной аккумуляции подвижных форм фосфора и калия в пахотном слое. Так, корреляция содержания подвижных фосфатов и калия с общим азотом составила 0,45 и 0,97 соответственно. Среднее содержание подвижных фосфатов зафиксировано в черноземах и темно-каштановой почве (15,3–23,6 мг/кг), низкое – в каштановой. Обеспеченность калием изменялась от очень высокой в почвах Ширинской степи до высокой и повышенной в южных черноземах и каштановых почвах Койбалльской и Уйбатской степей.

**Ключевые слова:** Хакасия, сельскохозяйственные почвы, почвенная морфология, агрохимия

## Fertility of steppe soils of the Republic of Khakassia

✉ Altaev A.A., Biltuev A.S., Ulanov A.K.

*Buryat Research Institute of Agriculture – Branch of the Siberian Federal Scientific Centre of Agro-BioTechnologies of the Russian Academy of Sciences*

Ulan-Ude, Russia

✉ e-mail: burniish@inbox.ru

Soil-geobotanical survey of the main erosion-prone agricultural landscapes of the steppe zone of the Republic of Khakassia was carried out by laying six benchmark sites on the testing areas selected by the Earth remote sensing method. Based on the morphological description of the sections, the following soil types were identified: ordinary and southern chernozem, dark chestnut and chestnut soils. The projective coverage of ordinary black soil was 58%, southern black soil – 35–66%, dark chestnut soil – 60%, chestnut soil – 40%. Vegetation cover on the arable soils is represented by cultivated and weedy vegetation, on the pastures – by herbaceous associations with fine- and sod forming plants of true steppes. Genetic horizons of the studied sections correspond to the soil type. Soil fertility is very low due to both soil formation factors and natural and anthropogenic digression processes. The close occurrence of carbonates from the surface (20–35 cm) with low precipitation and predominance of

exudational water regime resulted in alkalinization of the upper (0–20 cm) soil layer. Calcium predominates among the absorbed bases. Its content relative to magnesium concentration is 2.5 and 5.5 times higher on chestnut and chernozem soils, respectively. The most fertile soils formed in the most moistened Shirinskaya steppe contain up to 3.3–3.4% of organic matter. In the soils of drier steppes in the southern part of the republic there is a decrease in organic matter content to 2.1–2.9%. The concentration of total nitrogen also varied in accordance with the organic matter content, ranging from 0.17–0.29 mg/kg. Medium and high degree of biogenic accumulation of mobile forms of phosphorus and potassium in the arable layer was noted. Thus, the correlation of mobile phosphate and potassium content with total nitrogen was 0.45 and 0.97, respectively. The average content of mobile phosphates was recorded in chernozems and dark chestnut soil (15.3–23.6 mg/kg), low – in chestnut soil. Potassium supply varied from very high in the soils of Shirinskaya steppe to high and elevated in southern chernozems and chestnut soils of Koibalskaya and Uibatskaya steppes.

**Keywords:** Khakassia, agricultural soils, soil morphology, agrochemistry

**Для цитирования:** *Алтаев А.А., Билтуев А.С., Уланов А.К.* Плодородие степных почв Республики Хакасия // Сибирский вестник сельскохозяйственной науки. 2024. Т. 54. № 10. С. 13–24. <https://doi.org/10.26898/0370-8799-2024-10-2>

**For citation:** Altaev A.A., Biltuev A.S., Ulanov A.K. Fertility of steppe soils of the Republic of Khakassia. *Sibirskii vestnik sel'skokhozyaistvennoi nauki* = *Siberian Herald of Agricultural Science*, 2024, vol. 54, no. 10, pp. 13–24. <https://doi.org/10.26898/0370-8799-2024-10-2>

#### **Конфликт интересов**

Авторы заявляют об отсутствии конфликта интересов.

#### **Conflict of interest**

The authors declare no conflict of interest.

#### **Благодарность**

Исследование проведено в рамках выполнения работ по теме «Национальная программа действий по борьбе с опустыниванием Республики Хакасия», по Соглашению Бурятского научно-исследовательского института сельского хозяйства с Федеральным научным центром агроэкологии, комплексных мелиораций и защитного лесоразведения Российской академии наук № 05-11/ВИП ГЗ от 30 мая 2023 г.

#### **Acknowledgements**

The study was conducted as part of the work on the topic "National Action Program to Combat Desertification of the Republic of Khakassia", according to the Agreement of the Buryat Research Institute of Agriculture – branch of the SFSCA with the Federal Research Center for Agroecology of the Russian Academy of Sciences No. 05-11/VIP GZ dated May 30, 2023.

## **INTRODUCTION**

The Republic of Khakassia, located in the Altai-Sayan mountainous region, is part of the Siberian Federal District and is part of the East Siberian economic region. As of January 1, 2021, the land fund of the Republic amounted to 6156.9 thousand hectares, of which 30.4% (1871.9 thousand hectares) was occupied by agricultural land<sup>1</sup>. The trends of climate aridization in the world cause a number of negative processes that reduce the productivity of agricultural land<sup>2</sup> [1], and the temperature increase

in Russia since the beginning of the twentieth century has averaged 0.9...1.1 °C [2]. Thus, in the southern regions of Western Siberia, including the Republic of Khakassia, the main factors of land vulnerability are and are predicted to be heat waves, droughts, dust storms, dry winds, wind erosion (see footnote 2). Significant potential erosion hazard of the agricultural part of the region's territory is also indicated by the results of scientific research of the Research Institute of Agrarian Problems of Khakassia [3–5].

<sup>1</sup>Report on the state and use of land in the Republic of Khakassia in 2020 / Federal Service of State Registration, Cadastre and Cartography. URL: <https://rosreestr.gov.ru/> (date of reference: 06.10.2024).

<sup>2</sup>National report "Global climate and soil cover of Russia: drought manifestations, measures of prevention, control, elimination of consequences and adaptation measures (agriculture and forestry)" / ed. by R.S.-Kh. Edelgeriev, Moscow, 2021, vol. 3, 700 p.

In general, in the typical composition of arable and post-agricultural soils on the territory of Khakassia chernozems of different subtypes prevail: low-moisture ordinary chernozems are mainly developed on hills and hills, southern chernozems lie lower on the southern slopes, medium-moisture ordinary chernozems, sometimes leached chernozems are located on the northern slopes. In the valley there are slightly saline and deeply slightly saline southern and ordinary chernozems. Chestnut soils are confined mainly to plain relief elements, which correspond to ancient river terraces [6]. According to agro-ecological zoning of the territory of Khakassia, four agrolandscape regions (dry-steppe Priabakan-Uybatsky, steppe Sayan-Altaisky, forest-steppe Sayan-Altaisky and sub-taiga Sayan-Altaisky), seven agro-ecological groups and 11 types of land have been identified in the erosion-prone agricultural part of the republic [4, 5]. The main steppe areas of Khakassia are confined to the Minusinsk Basin - transformed low-bush-grass common cattail, fescue-feather grass, sedge-fescue with common cattail and koeleria and fine-wormwood-fescue steppes<sup>3</sup> [7].

The present-day soil cover of Khakassia is very heterogeneous due to differences in the geomorphology of the districts and their history. The spatial distribution of soils shows latitudinal zonality and vertical belt [6, 8]. According to the degree of humus content, 41.6% (214.9 thousand hectares) of arable land are low- and low-humus soils (containing less than 4% of humus), 36.6% – medium-humus soils and only 21.8% of soils are characterized by a high degree of humus content. On the whole in the republic the soils contain 4.7% of humus, its reserves in 0–20 cm layer are 95–110 t/ha [8, 9].

The purpose of the study is to determine the current level of fertility of the main erosion-prone agricultural landscapes of the steppe zone of the Republic of Khakassia.

The objectives are:

- 1) laying out soil transects and conduct morphological description of typical soils of the study sites;
- 2) conducting a geobotanical survey of the studied agro-landscapes;
- 3) assessment of the fertility of the studied soils according to soil-agrochemical indicators;
- 4) development of the proposals on preservation and restoration of dry pastures, as well as an increase of their productivity.

## MATERIAL AND METHODS

The Buryat Research Institute of Agriculture within the framework of research on the subject of “National Action Program to Combat Desertification” in the territory of the Republic of Khakassia in 2022 and 2023 six reference plots were laid out on polygons selected by the Earth remote sensing (ERS) and subsequent route soil-geobotanical survey (see fig. 1). The survey plots were located in the main erosion-hazardous landscapes of the steppe zone on the territory of three districts of the republic (see Table 1). The survey area can be divided into two aerial landscape regions with different soil-climatic potential: Sayan-Altaisky (Shirinskaya steppe) and Priabakan-Uybatsky dry-steppe (Koibalsky and Uybatskaya steppes) [5].

According to geographical zoning, the study sites are located in different geographical points of the Nazarovsk-Minusinsk intermountain depression: within the Chebakovo-Balakhtinskaya Basin in the zone of location of the Shirinskaya lake-kettlehole steppe (polygons Borets and Tselinnoye), in the Minusinsk Basin in the zone of location of the Uybatskaya (Zarya, Vesenne) and Koibalskaya steppes (Krasnopolye, Berezovka).

Climatic characteristics of the agrolandscape areas differ significantly. The Shirinskaya steppe is moderately dry with an average annual precipitation of 320-380 mm and HTC = 0.8-0.12 (according to Selyaninov). Dry Uybatskaya and

<sup>3</sup>Gadzhiev I.M., Korolyuk A.Yu., Titlyanova A.A., Andrievsky V.S., Grishina L.G., Kosykh N.P., Kyrgyz Ch.O., Romanova I.P., Sambuu A.D., Smelyansky I.E. Steppes of Central Asia. Novosibirsk, 2002, 299 p.



Рис. 1. Расположение реперных участков

Fig. 1. Location of the benchmark sites

Табл. 1. Почвенно-ландшафтная характеристика территории размещения реперных участков

Table 1. Soil-landscape characteristics of the territory of benchmark site location

Polygon	Soil	Type of degradation	District	Terrain
Borets	Ordinary chernozem	Water erosion	Shirinsky	Shirinskaya lake-kettlehole steppe. Steppe foothill terrain
Tselinnoye	Dark chestnut	»	»	The same
Berezovka	Southern chernozem	Water erosion, deflation	Altaysky	Koibalskaya steppe. Steppe South Siberian plain terrain
Krasnopolye	»	The same	»	The same
Vesennee	Dark chestnut	»	Ust-Abakansky	Uybatskaya steppe. Steppe South Siberian plain terrain
Zarya	Southern chernozem	»	»	The same

Koibalskaya steppes are characterized by more aridity: the sum of precipitation is 250–300 mm,  $HTC = 0.80$  (according to Selyaninov)<sup>4</sup>.

Mixed soil samples were taken from the 0–20 cm layer. The soils were described according to the classification 1977<sup>5</sup>. Chemical analysis of the soils was carried out in the accredited testing laboratory of the State station of agrochemical service “Khakasskaya” according to the standard methods accepted in the agrochemical service<sup>6</sup>.

## RESULTS AND DISCUSSION

In soil-geographical respect<sup>7</sup> the area of distribution of lakeside landscapes belongs to the Minusinsk province of ordinary and southern chernozems and the Tuva province of dark chestnut and chestnut soils. The general character and direction of soil formation process here are determined by peculiarities of bioclimatic conditions. Severity of ecological conditions connected with long freezing of soils, short vegetation period, dry spring, uneven precipitation and sharp fluctuations of daily and annual temperatures, causes essential regional differences of steppe soil formation in Khakassia from the processes occurring in the steppe zone of the European territory of Russia. Organic matter is supplied to the soils mainly by underground plant organs concentrated in the upper, most moistened and warmed thickness of the soil profile. Low productivity of phytocenoses and poor movement of soil formation products cause general low thickness and low humus of zonal soils (see fig. 2).

The formation of soil cover of the steppe zone of Khakassia is also accompanied by a significant manifestation of exogenous processes. Deflation, especially activated in dry years and in spring-early summer period, delays soil development at one stage. In this connection, the soils are often characterized by shortened profile thickness and underdevelopment<sup>8</sup>. Fertility of the degraded soils was studied on polygons in different soil-geographical areas of the Republic: within the Chebakovo-Balakhtinskaya (polygons Borets, Tselinnoe) and Minusinsk basins (Zarya, Vesennee, Krasnopolye, Berezovka) of the Nazarovsk-Minusinskaya intermountain depression<sup>9</sup>.

### *Morphological description of typical soils of the study sites*

The Borets polygon is located on the steppe plain area at the foot of the slope. The relief is plain and hilly. To characterize the morphological features of the soil, a transect 9.7 km north-east of the village of Borets was laid on arable land. The projective coverage of the field after harvesting oats is 58%. Cultural and weedy vegetation is found on the plot: *Avena sativa* (33,0%), *Setaria glauca* (2,0), *Erodium cicutarium* (1,7), *Vicia cracca* (1,0), *Milium effusum* L. (1,0), *Sonchus arvensis* (0,9), *Vicia segetalis* (0,9), *Elytrigia repens* (0,7), *Fallopia convolvulus* L. (0,5), *Lactuca tatarica* L. (0,3%).

The soil profile is represented by the following horizons:

1. A<sub>p</sub> (plow horizon), 0–19 cm – dark gray in color, moist, loose, the structure of soil ag-

<sup>4</sup>Subregional National Action Program to Combat Desertification for the South of Middle Siberia of the Russian Federation (Republic of Khakassia, Republic of Tuva, southern districts of the Krasnoyarsk Territory) / ed. by V.K. Savostyanov, Abakan, 2000, 260 p. <sup>5</sup>Classification and diagnostics of the soils of the USSR. Moscow: Kolos, 1977, 224 p.

<sup>6</sup>GOST 26423-85. Soils. Methods of determination of specific electrical conductivity, pH and dense residue of water extract. Moscow: Standardinform, 2011; GOST 26205-91. Soils. Determination of mobile compounds of phosphorus and potassium by the method of Machigin in modification of CINAО. Moscow: Publishing House of Standards, 1992; GOST 26213-2021. Soils. Methods of determination of organic matter. Moscow, 2021; GOST 26487-85. Soils. Determination of exchangeable calcium and exchangeable (mobile) magnesium by CINAО methods. Moscow, 1986.

<sup>7</sup>Dobrovolsky G.V., Urusevskaya I.S. Geography of soils: textbook for students of higher educational institutions. Moscow, 2006, 458 p.

<sup>8</sup>Shamshayeva V.F. Soils of lakeside landscapes of the steppe zone of Khakassia: extended abstract of candidate's thesis in biology, Tomsk, 2003, 20 p.

<sup>9</sup>Kutkina N.V., Eremina I.G. Agrolandscape land zoning in Khakassia // Soil resources and their rational use: materials of the All-Russian scientific-practical conference dedicated to the 100th anniversary of the birth of Dr. of Science in Agriculture, Prof. P.S. Bugakov (Krasnoyarsk, 22 April, 2022). Krasnoyarsk, 2022, pp. 36-41.

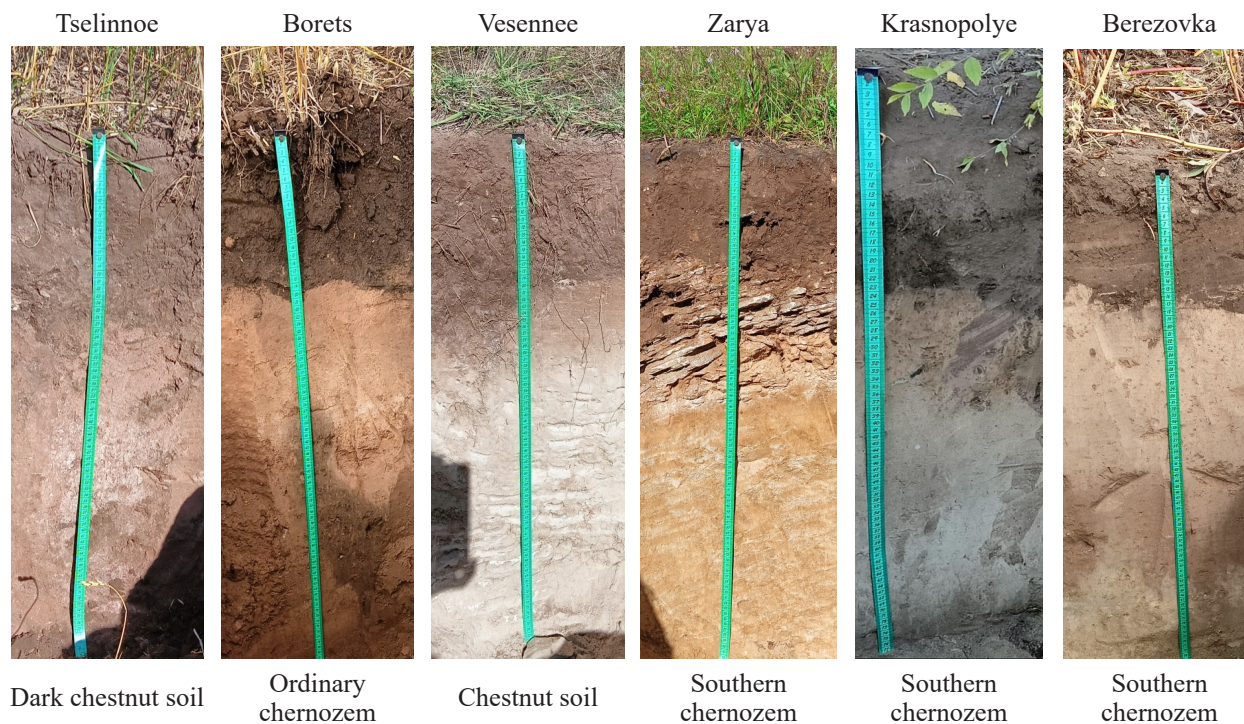

**Рис. 2.** Почвенные разрезы

**Fig. 2.** Soil sections

gregates is crumbly, there are inclusions of plant roots, no new formations, the transition to the underlying horizon is sharp in color, effervescence with HCl is vigorous, the granulometric composition is medium loamy (physical clay content is 38.7%).

2. B, 19–55 cm – light brown in color, moist, structureless, dense, no inclusions or new formations, the transition to the underlying horizon is tongued (irregular), the reaction with HCl is vigorous, the granulometric composition is medium loamy.

3. BC, 55–82 cm – brown in color, fresh (moist), structureless, dense, there are inclusions of small gravel, the reaction with HCl is vigorous, the granulometric composition is sandy loam.

Soil type – ordinary carbonate medium-loamy weakly eroded chernozem on deluvial deposits<sup>10</sup>.

*The Tselinnoe polygon* is located on a plain-hilly area with elevation differences of 130–140 meters. The soil profile was established in the

middle part of a gentle slope on arable land, 7.9 km northeast of the village of Zhemchuzhny. The projective cover of the field under wheat is 60%. The vegetation cover consists of the following species: *Triticum aestivum* (31,0%), *Avena sativa* (2,0), *Milium effusum* L. (2,0), *Taraxacum officinale* (1,0), *Setaria glauca* (1,0), *Sonchus arvensis* (0,9), *Erodium cicutarium* (0,9), *Fallopia convolvulus* L. (0,9), *Hordeum vulgare* (0,3%).

The soil profile is represented by the following horizons:

1. A<sub>p</sub> horizon, 0–19 cm – dark gray in color, fresh (moist), the structure is crumbly to fine crumbly, the density is loose, there are inclusions of plant roots, no new formations, the transition to the underlying horizon is sharp in terms of density, the reaction to 10% HCl is vigorous, the granulometric composition is heavy loamy (physical clay content is 42.2%).

2. AB horizon, 19–26 cm – dark brown in color, fresh (moist), the structure of soil aggregates is crumbly to dusty, the density is compact, there are inclusions of plant roots, new formations of

<sup>10</sup>Classification and diagnostics of the soils of Western Siberia (instruct. materials for soil mapping). Novosibirsk, 1979, 48 p.

siliceous-gypsum concretions, the transition to the underlying horizon is distinct, the reaction to 10% HCl is vigorous, the granulometric composition is heavy loamy.

3. B horizon, 26–79 cm – light brown in color, fresh (moist), the structure of soil aggregates is dusty, the density is loose, no inclusions, new formations are white soft spots (calcareous concretions, 1.0–1.5 cm in diameter), the reaction to 10% HCl is vigorous, the granulometric composition is medium loamy.

The soil is dark chestnut carbonate medium-loamy deflated (wind-eroded) on deluvial-eluvial deposits.

*The Berezovka polygon* is located 6.7 km southwest of the village of Berezovka, on the upper part of a gentle slope in a buckwheat field. The relief is hilly with elevation differences of 160–170 meters. The projective cover is 60%. The vegetation is represented by the following species: *Polygonum fagopyrum* (20,0%), *Sonchus arvensis* (4,0), *Erodium cicutarium* (3,0), *Convolvulus arvensis* (3,0), *Milium effusum* L. (1,0), *Lactuca tatarica* L. (1,0), *Atriplex patula* L. (1,0), *Alopecurus myosuroides* (1,0), *Taraxacum officinale* (1,0), *Camelina sativa* (1,0), *Agrostis stolonifera* (1,0), *Galium aparine* (1,0), *Eriophorum vaginatum* (1,0), *Vicia segetalis* (1,0%).

The soil profile is represented by the following horizons:

1. A<sub>p</sub> horizon, 0–17 cm – dark gray in color, fresh (moist), dense, the structure is fine crumbly, there are inclusions of plant roots, no new formations, the transition to the underlying horizon is sharp in terms of color and density, effervescence (with HCl) is vigorous, the granulometric composition is light loamy (physical clay content is 24.6%).

2. AB horizon, 17–45 cm – light brown in color, fresh (moist), structureless, dense, there are inclusions of roots, no new formations, the transition to the underlying horizon is gradual, the reaction to 10% HCl is vigorous, the granulometric composition is light loamy.

3. B horizon, 45–70 cm – pale yellow in color, fresh (moist), loose, the structure is dusty, no

inclusions or new formations, there is no reaction to 10% HCl, the granulometric composition is sandy loam.

The soil is carbonate medium-loamy moderately eroded southern chernozem on alluvial deposits.

*The Krasnopolye polygon* is located 7.8 km northwest of the village of Krasnopolye, on a north-facing slope. The terrain is hilly with an elevation difference of 115–120 meters. The land use is pasture. The vegetation is represented by an elm-forb association: *Ulmus pumila* L. (9,0%), *Artemisia vulgaris* (2,0), *Artemisia frigida* (2,0), *Carex acuta* (2,0), *Teloxys aristata* (1,0), *Sonchus arvensis* (1,0), *Barbarea vulgaris* Ait. f. (1,0), *Galium aparine* (1,0), *Thlaspi arvense* Linn. (1,0), *Convolvulus arvensis* (1,0), *Vicia cracca* (1,0), *Camelina sativa* (1,0), *Taraxacum officinale* (1,0), *Phleum pratense* (1,0), *Salsola tragus* (1,0%). The projective cover is 35%.

The typical soil profile is represented by the following horizons:

1. A horizon, 0–23 cm – dark brown in color, dry, loose, the structure is crumbly to dusty, there are inclusions of plant roots, no new formations, the transition to the underlying horizon is sharp in terms of color and density, effervescence occurs at the surface, the granulometric composition is light loamy (physical clay content is 29.2%).

2. AB horizon, 23–34 cm – dark brown in color, fresh (moist), crumbly structure, the density is compact, there are inclusions of roots, the transition to the underlying horizon is distinct in terms of color, the reaction to 10% HCl is vigorous, the granulometric composition is light loamy.

3. BB horizon, 34–77 cm – pale yellow (buff) in color, fresh (moist), dense, the structure is powdery, there are inclusions of roots (mainly dwarf elm), no new formations, the reaction to 10% HCl is vigorous, the granulometric composition is sandy loam.

The soil is carbonate medium-loamy moderately eroded southern chernozem on deluvial-eluvial deposits.

The *Vesennee polygon* is located on a gentle slope, 9.4 km southeast of the village of Vesennoye. The terrain is plain-hilly with small elevation differences of up to 10 meters. The vegetation cover consists of small and large tussock plants of true steppes and forbs: *Stipa lessingiana* (14,0%), *Aster amellus* (5,0), *Artemisia vulgaris* (4,0), *Artemisia frigida* (3,0), *Taraxacum officinale* (3,0), *Teloxys aristata* (2,0), *Agropyron pectinatum* (2,0), *Elymus junceus* Fisch. (1,0), *Echinochloa crus-galli* (1,0), *Alopecurus pratensis* (1,0), *Iris sibirica* (1,0), *Plantago psyllium* (1,0), *Gnaphalium uliginosum* (1,0), *Myosotis arvensis* (1,0%). The projective cover is 40%.

The soil profile, established on a pasture, is represented by the following horizons:

1. A horizon, 0–20 cm – brown in color, dry, dense, the structure is crumbly to nutty, there are inclusions of stones and plant roots, no new formations, the transition to the underlying horizon is distinct in terms of color and density, effervescence is vigorous at the surface, the granulometric composition is medium loamy (physical clay content is 31.2%).

2. AB horizon, 20–33 cm – light brown in color, fresh (moist), dense, the structure is fine crumbly, there are inclusions of plant roots and carbonates, new formations include cutans, the transition to the underlying horizon is gradual, effervescence (with HCl) is vigorous, the granulometric composition is light loamy.

3. B horizon, 33–80 cm – light gray in color, fresh (moist), dense, the structure is platy, there are inclusions of stone slabs and carbonates, no new formations, the reaction to HCl is vigorous, the granulometric composition is sandy loam.

The soil is chestnut carbonate medium-loamy on deluvial-alluvial deposits.

The *Zarya polygon* is located on a gently hilly area with an elevation difference of 60–70 meters, 2.8 km southwest of the village of Zarya. The soil profile was established on a gentle north-facing slope in pastureland. The vegetation is steppe forbs: *Poa angustifolia* (17,0%), *Aster amellus* (15,0), *Artemisia frigida* (14,0), *Taraxacum officinale* (5,0), *Artemisia vulgaris*

(3,0), *Elytrigia repens* (3,0), *Teloxys aristata* (2,0), *Barbarea vulgaris* (2,0), *Senecio vulgaris* (1,0), *Vicia cracca* (1,0), *Salsola tragus* (1,0), *Ambrosia artemisiifolia* (1,0), *Chelidonium majus* (0,7), *Linaria vulgaris* (0,3%). The projective cover is 66%.

A soil section was laid down at the site, represented by the following horizons:

1. A horizon, 0–20 cm – dark gray in color, fresh (moist), dense, the structure is crumbly, there are inclusions of stones and small plant roots, no new formations, the transition to the underlying horizon is sharp in terms of color and density, the reaction to HCl is vigorous, the granulometric composition is light loamy (physical clay content is 29.7%).

2. BCA horizon, 20–45 cm – yellow-brown in color, fresh (moist), dense, the structure is platy, there are inclusions of carbonates, no new formations, the transition to the underlying horizon is sharp in terms of density, the reaction to HCl is vigorous, the granulometric composition is light loamy.

3. BC horizon, 45–92 cm – brown in color, fresh (moist), moderately dense, the structure is granular-powdery, no inclusions or new formations, there is no reaction to 10% HCl, the granulometric composition is sandy loam.

The soil is carbonate medium-loamy southern chernozem on deluvial-alluvial deposits.

The landscape of the studied sites is predominantly plain-hilly with elevation differences of 70–170 meters. Typical polygons are located on slopes of various aspects and gradients. In this regard, the soils are erosion-prone and subject to varying degrees of deflation and water erosion. The soils are cultivated and used as arable land and pastures.

#### *Agrochemical parameters of the soils*

The fertility of the degraded soils is very low, influenced by both soil-forming factors and degenerative processes of natural and anthropogenic origin (see Table 2). Acid-base properties are one of the main physicochemical indicators of soils, determining their productivity. Environmental conditions significantly affect the mi-

**Табл. 2.** Агрохимические показатели почв полигонов исследования**Table 2.** Agrochemical indicators of the study site soils

Polygon, soil	pH <sub>water</sub>	Organic matter (mass fraction)	N <sub>total</sub>	P <sub>2</sub> O <sub>5</sub> mobile	K <sub>2</sub> O exchangeable	Ca <sup>2+</sup>	Mg <sup>2+</sup>	Solids
		%		mg/kg (according to Machigin)		mg-eq /100 g		%
Borets, ordinary medium loamy chernozem	7,9 ± 0,1	3,4	0,29 ± 0,03	19,8 ± 4,0	> 500	19,4 ± 1,0	2,50 ± 0,25	0,18 ± 0,04
Tselinnoye, dark chestnut brown medium loamy soil	7,9 ± 0,1	3,3	0,28 ± 0,03	23,6 ± 4,7	> 500	14,8 ± 0,7	6,00 ± 0,60	0,17 ± 0,03
Berezovka, medium loamy southern chernozem	7,8 ± 0,1	2,5	0,20 ± 0,02	19,3 ± 3,9	171 ± 17	12,9 ± 0,6	1,50 ± 0,19	0,15 ± 0,03
Krasnopolye, medium loamy southern chernozem	7,6 ± 0,1	2,1	0,17 ± 0,01	15,3 ± 3,1	136 ± 14	11,9 ± 0,6	0,75 ± 0,09	0,13 ± 0,03
Vesennee, chestnut medium loamy	7,7 ± 0,1	2,9	0,22 ± 0,02	9,16 ± 2,7	222 ± 22	9,5 ± 0,5	3,88 ± 0,39	0,29 ± 0,06
Zarya, medium loamy southern chernozem	7,8 ± 0,1	2,7	0,20 ± 0,02	19,7 ± 5,9	198 ± 20	12,5 ± 0,6	2,25 ± 0,23	0,15 ± 0,03

crobiological and enzymatic activity of soils, as well as the root nutrition of plants. The shallow occurrence of carbonates near the soil surface (20–35 cm), combined with low precipitation and a predominant evaporative water regime, led to the alkalization of the upper 20-centimeter soil layer. As a result, all soil types were characterized by a weakly alkaline reaction (pH 7.6–7.9). Among the absorbed bases, calcium predominates. In chestnut and chernozem soils, its content was several times higher than that of magnesium—2.5 and 5.5 times, respectively.

The soils of the studied polygons are medium-loamy in granulometric composition, which ensures a potentially favorable water and air regime for functioning. However, under conditions of moisture deficit and prolonged seasonal frost, they have low productivity and are unable to ac-

cumulate significant amounts of organic matter. The most fertile soils, formed in the more humid Shirinskaya steppe, contain up to 3.6–3.8% organic matter. In the soils of the drier steppes in the southern part of the republic (Koibalskaya and Uybatskaya steppes), there is a decrease in organic matter content to 2,1–2,9%.

This is related not only to soil-forming conditions but also to the active development of deflation processes—the main factors of dehumification in arable soils<sup>11</sup>. In accordance with the content of organic matter (mass fraction), the content of total nitrogen also varied within 0,17–0,29 мг/ кг<sup>12</sup>.

The content of available phosphorus and potassium in the soils depended on the mineral composition of the parent material and the degree of their weathering. A moderate to high

<sup>11</sup>Rozhentsova A.V., Spirina V.Z. Steppe black soils of the left bank of the Minusinsk depression // Reflection of bio-, geo-, anthropospheric interactions in soils and soil cover: Proceedings of the VII International Scientific Conference dedicated to the 90th anniversary of the Department of Soil Science and Soil Ecology TSU (Tomsk, September 14–19, 2020), Tomsk, 2020, pp. 292–296.

<sup>12</sup>Biltuev A.S., Lapukhin T.P., Budazhapov L.V. Climate, soil fertility and productivity of grain crops in the arid conditions of Transbaikalia: status and forecast. Ulan-Ude, 2015, 141 p.

level of biogenic accumulation of these elements was recorded in the plow layer. The average content of available phosphates was observed in chernozems and dark chestnut soils (15.3–23.6 mg/kg), while low levels were found in chestnut soils. The potassium availability ranged from very high in the soils of the Shirinskaya steppe to high and elevated in the southern chernozems and chestnut soils of the Koibalskaya and Uybatskaya steppes. The studied soils of Khakassia are characterized by a very significant (9–25 times) excess of available potassium compared to phosphorus. This trend is typical for most steppe soils in the republic<sup>13</sup>. The studied soils are not saline, and the content of the solid residue did not exceed 0.3% [10, 11].

The most fertile soils of Khakassia are located in the northern part of the republic, in the steppe Sayan-Altai aerolandscape region (Shirinskaya lake-basin steppe). The soil-forming conditions have allowed the formation of the most fertile soils here—ordinary chernozems, which possess a combination of favorable water-physical and agrochemical properties for cultivating field crops. Data from five rounds of agrochemical surveys (1966–2003) have shown a dynamic decline in the content of humus, available phosphorus, and potassium. This is due not only to insufficient application of organic and mineral fertilizers but also to the development of erosion processes on sloping lands [5, 12]. The true arid steppes are located in the southern part of the republic, in the dry-steppe Priabakan-Uybatsky agrolandscape region (Koibalskaya and Uybatskaya steppes), where the soil cover is mainly composed of southern chernozems and chestnut soils. These soils are low in humus and have low potential fertility in terms of nitrogen. Effective fertility in terms of phosphorus is moderate in southern chernozems and low in chestnut soils, while in terms of potassium, it is elevated and high, respectively. The soils require measures to increase fertility levels

and reduce the impact of deflation. At the same time, the Koybalskaya steppes are the most susceptible to deflation [12, 13].

## CONCLUSION

The soils of the steppe territories in the Republic of Khakassia are located in the Sayan-Altai and Priabakan-Uybatsky aerolandscape regions, which differ in natural and climatic conditions and, accordingly, in potential fertility. The most fertile ordinary chernozems predominate in the steppes of the Sayan-Altai region and are primarily used in field crop production. Due to the highly dissected relief, the soils are susceptible to water erosion. To prevent water erosion on sloping lands, anti-erosion measures developed by the Research Institute of Agrarian Problems of Khakassia are recommended. Special attention should also be paid to the fertilizer application system aimed at maintaining effective fertility.

In the southern steppes, the zonal soils are southern chernozems and chestnut soils, which are characterized by lower nitrogen and phosphorus content. The predominant agricultural activity on these lands is livestock farming, including nomadic practices. The main factor in the degradation of these soils is deflation. The existing experience in Eastern Siberia for improving pasturelands in regions with developed livestock farming shows that the primary way to improve degraded pastures in dry steppes is the rationalization of their use within a pasture rotation system. The preservation and restoration of dry pastures, as well as increasing their productivity, should focus on the following directions:

1. Rationalization of use based on a pasture rotation system. The introduction of pasture rotation fundamentally changes the technology of free-range grazing, creating opportunities for planned pasture management and differentiated,

<sup>13</sup>*Spirina V.Z.* Black soils of Minusinsk flexure on red-colored loams // Soil resources of Siberia: challenges of the XXI century: proceedings of the All-Russian scientific conference with international participation, dedicated to the 110th anniversary of the outstanding organizer of science and the first director of ISSA SB RAS R.V. Kovalev (Novosibirsk, 4-8 December 2017) / edited by A.I. Syso, Novosibirsk, 2017, Ch. 1, pp. 139-142.

regulated stocking rates on pasture areas, taking into account their productivity.

2. Application of the methods for fundamental and surface improvement of low-productivity and degraded pastures. At the same time, the choice of measures should be approached selectively, taking into account local specifics based on geobotanical and agrochemical surveys of the area. For overseeding grasses, it is advisable to use local seed material from natural lands with high productivity and valuable herbage. The pasture rotation system should include the mandatory application of mineral nitrogen fertilizers during grassland renovation and the period of spring grass regrowth. Mountainous areas have a high coverage of water sources. Water reclamation in these areas will significantly increase pasture productivity and improve the fertility of the degraded areas.

Since the conducted studies only determine the current status of soils and vegetation cover, monitoring surveys of the territories using spectral analysis of landscapes and Earth remote sensing are necessary to determine the rates and direction of degradation processes.

## СПИСОК ЛИТЕРАТУРЫ

1. *Snakin V.V.* Low-carbon energy and global climate warming // *Life of the Earth*. 2024. Vol. 46. N 1. P. 4–19. DOI: 10.29003/m3770.0514-7468.2024\_46\_1/4-19.
2. *Анисимов О.А., Жильцова Е.Л., Шаповалова К.О., Ершова А.А.* Анализ индикаторов изменения климата. Ч. 1: Восточная Сибирь // *Метеорология и гидрология*. 2019. № 12. С. 31–42.
3. *Кутькина Н.В., Еремина И.Г.* Демутация и биопродуктивность залежи в условиях холмисто-сопочной степи Хакасии // *Вестник Красноярского государственного аграрного университета*. 2021. № 10 (175). С. 3–10. DOI: 10.36718/1819-4036-2021-10-3-10.
4. *Чебоचाков Е.Я., Муртаев В.Н.* Противоэрозийная эффективность технологии освоения залежных земель в степной зоне // *Вестник Казанского государственного аграрного университета*. 2020. Т. 15. № 1 (57). С. 43–47. DOI: 10.12737/2073-0462-2020-43-47.
5. *Чебоचाков Е.Я., Шапошников Г.М., Кансаргин А.И., Муртаев В.Н.* Совершенствование агроландшафтного районирования эрозийно опасной территории Республики Хакасия и агроэкологическая группировка земель // *Вестник Красноярского государственного аграрного университета*. 2019. № 10. С. 24–31.
6. *Еремина И.Г., Кутькина Н.В.* Информационная база данных почв Республики Хакасия // *Аграрная наука*. 2022. № 4. С. 88–92. DOI: 10.32634/0869-8155-2022-358-43-88-92.
7. *Королюк А.Ю.* Степи Назаровско-Минусинской межгорной впадины: синтаксономическая ревизия // *Растительный мир Азиатской России*. 2022. Т. 15. № 3. С. 171–190. DOI: 10.15372/RMAR20220301.
8. *Чебоचाков Е.Я., Муртаев В.Н.* Современное состояние использования пахотных земель в хозяйствах разных форм собственности Приенисейской Сибири // *Вестник Красноярского государственного аграрного университета*. 2021. № 2 (167). С. 10–16. DOI: 10.36718/1819-4036-2021-2-10-16.
9. *Ковалева Ю.П., Тарбеев В.А., Мамонтова С.А., Колтакова О.П., Иванова О.И.* Оценка мелиоративного состояния орошаемых земель Республики Хакасия // *International Agricultural Journal*. 2024. N 2. P. 326–344. DOI: 10.55186/25876740\_2024\_8\_2\_9.
10. *Градобоева Н.А., Елизарьев В.В., Сиренева Н.В.* Мониторинг почвенного плодородия пахотных земель Республики Хакасия // *Достижения науки и техники АПК*. 2019. Т. 30. № 7. С. 44–47.
11. *Иванов А.Л., Савин И.Ю., Столбовой В.С., Аветян С.А., Шишконокова Е.А., Каишинов А.Н.* Карта агрогенной эродированности почв России // *Доклады Российской академии наук. Науки о Земле*. 2020. Т. 493. № 2. С. 99–102. DOI: 10.31857/S2686739720080095.
12. *Чебоचाков Е.Я., Муртаев В.Н.* Агроэкологическая оценка технологии обработки чернозема обыкновенного залежи на юге Средней Сибири // *Аграрная наука*. 2023. № 4. С. 101–104. DOI: 10.32634/0869-8155-2023-369-4-101-104.
13. *Чебоचाков Е.Я., Муртаев В.Н.* Эффективность почвозащитной системы земледелия в условиях освоения залежных земель в Приенисейской Сибири // *Вестник Красноярского государственного аграрного университета*. 2020. № 4. С. 66–73.

## REFERENCES

- Snakin V.V. Low-carbon energy and global climate warming. *Life of the Earth*, 2024, vol. 46, no. 1, pp. 4–19. DOI: 10.29003/m3770.0514-7468.2024\_46\_1/4-19.
- Anisimov O.A., Zhiltsova E.L., Shapovalova K.O., Ershova A.A. Analysis of climate change indicators. Part 1: Eastern Siberia. *Meteorologiya i gidrologiya = Russian Meteorology and Hydrology*, 2019, no. 12, pp. 31–42. (In Russian).
- Kut'kina N.V., Eremina I.G. Fallow lands demutation and bioproductivity under Khakass hilly steppe conditions. *Vestnik KrasGAU = Bulletin of KrasSAU*, 2021, no. 10 (175), pp. 3–10. (In Russian). DOI: 10.36718/1819-4036-2021-10-3-10.
- Chebochakov E.Ya., Murtaev V.N. Anti-erosion efficiency of fallow lands development technologies in the steppe zone. *Vestnik Kazanskogo gosudarstvennogo agrarnogo universiteta = Vestnik of the Kazan State Agrarian University*, 2020, vol. 15, no. 1 (57), pp. 43–47. (In Russian). DOI: 10.12737/2073-0462-2020-43-47.
- Chebochakov E.Ya., Shaposhnikov G.M., Kapsargin A.I., Murtaev V.N. The improvement of agrolandscape zoning of erosionally hazardous territory of the Republic of Khakassia and agroecological lands grouping. *Vestnik KrasGAU = Bulletin of KrasSAU*, 2019, no. 10, pp. 24–31. (In Russian).
- Eremina I.G., Kut'kina N.V. Information database of soils of the Republic of Khakassia. *Agrarnaya nauka = Agrarian Science*, 2022, no. 4, pp. 88–92. (In Russian). DOI: 10.32634/0869-8155-2022-358-43-88-92.
- Korolyuk A.Yu. Steppes of the Nazarovsko-Minusinskaya intermountain depression: syntaxonomical revision. *Rastitel'nyy mir Aziatskoy Rossii = Flora and vegetation of Asian Russia*, 2022, vol. 15, no. 3, pp. 171–190. (In Russian). DOI: 10.15372/RMAR20220301.
- Chebochakov E.Ya., Murtaev V.N. Current state of the use of arable land in farms of different forms of ownership in Yenisei Siberia. *Vestnik KrasGAU = Bulletin of KrasSAU*, 2021, no. 2 (167), pp. 10–16. (In Russian). DOI: 10.36718/1819-4036-2021-2-10-16.
- Kovaleva Yu.P., Tarbeev V.A., Mamontova S.A., Kolpakova O.P., Ivanova O.I. Assessment of the reclamation status of irrigated lands of the republic Khakassia. *International Agricultural Journal = International Agricultural Journal*, 2024, no. 2, pp. 326–344. (In Russian). DOI: 10.55186/25876740\_2024\_8\_2\_9.
- Gradoboeva N.A., Elizariyev V.V., Sireneva N.V. Monitoring of soil fertility of arable lands of the Republic of Khakassia. *Dostizheniya nauki i tekhniki APK = Achievements of Science and Technology of AIC*, 2019, vol. 30, no. 7, pp. 44–47. (In Russian).
- Ivanov A.L., Savin I.Yu., Stolbovoy V.S., Avetyan S.A., Shishkonakova E.A., Kashtanov A.N. Map of agrogenic soil erosion in Russia. *Doklady Rossiyskoy akademii nauk. Nauki o Zemle = Reports of the Russian Academy of Sciences. Earth Sciences*, 2020, vol. 493, no. 2, pp. 99–102. (In Russian). DOI: 10.31857/S2686739720080095.
- Chebochakov E.Ya., Murtaev V.N. Agroecological assessment of the technology of processing ordinary chernozem deposits in the south of Central Siberia. *Agrarnaya nauka = Agrarian Science*, 2023, no. 4, pp. 101–104. (In Russian). DOI: 10.32634/0869-8155-2023-369-4-101-104.
- Chebochakov E.Ya., Murtaev V.N. The efficiency of soil protection system of farming in the development of fallow lands in the Yenisei Siberia. *Vestnik KrasGAU = Bulletin of KrasSAU*, 2020, no. 4, pp. 66–73. (In Russian).

## ИНФОРМАЦИЯ ОБ АВТОРАХ

✉ **Алтаев А.А.**, кандидат биологических наук, доцент, старший научный сотрудник, заведующий лабораторией; **адрес для переписки:** Россия, 670045, Улан-Удэ, ул. Третьякова, 25 «з»; e-mail: burniish@inbox.ru

**Билтуев А.С.**, кандидат биологических наук, доцент, старший научный сотрудник, заведующий лабораторией

**Уланов А.К.**, доктор сельскохозяйственных наук, доцент, ведущий научный сотрудник, заместитель директора

## AUTHOR INFORMATION

✉ **Alexander A. Altaev**, Candidate of Science in Biology, Associate Professor, Senior Researcher, Laboratory Head; **address:** 25 z, Tretyakova St., Ulan-Ude, 670045, Russia; e-mail: burniish@inbox.ru

**Alexander S. Biltuev**, Candidate of Science in Biology, Associate Professor, Senior Researcher, Laboratory Head

**Alexander K. Ulanov**, Doctor of Science in Agriculture, Associate Professor, Lead Researcher, Deputy Director

Дата поступления статьи / Received by the editors 19.06.2024  
Дата принятия к публикации / Accepted for publication 05.08.2024  
Дата публикации / Published 20.11.2024



<https://doi.org/10.26898/0370-8799-2024-10-3>

УДК: 633.521:577.21

Тип статьи: оригинальная

Type of article: original

## Динамика экспрессии генов десатуразы в процессе формирования семян масличного льна

✉ Базанов Т.А., Ущачовский И.В., Логинова Н.Н., Минина Е.В., Вересова П.Д.

Федеральный научный центр лубяных культур

Тверь, Россия

✉ e-mail: t.bazanov@fncl.ru

Масличный лен (*Linum usitatissimum* L.) – многоцелевая культура, используемая во многих отраслях промышленности. Состав масла семян традиционных сортов льна характеризуется высоким содержанием ненасыщенных жирных кислот типа Omega-3. В процессе биосинтеза липидов в клетке важным этапом является десатурация жирных кислот, определяющая итоговое соотношение насыщенных и ненасыщенных жирных кислот в масле. Основными ферментами, определяющими эффективность десатурации, являются мембраносвязанные десатуразы (FAD) и растворимые десатуразы (SAD). Цель данной работы – исследование экспрессии генов десатураз в процессе развития семян различных сортов льна масличного. Материалом для исследования послужили восемь сортов льна масличного с различным жирнокислотным составом масла. Образцы выращивали в растительной камере до цветения. На 5, 10, 15, 20, 25, 30 и 35-й день после цветения проводили отбор коробочек с растений с последующим извлечением РНК из семян. Выполняли обратную транскрипцию и полуколичественную RT-PCR. Полученные в результате реакции продукты разделяли с использованием 1,2%-го агарозного геля. Ген аденин фосфорилтрансферазы-1 (APT<sub>1</sub>) использовали как эталонный. В результате исследования получены данные по экспрессии шести генов десатураз льна: SAD1, SAD2, FAD2A, FAD2B, FAD3A и FAD3B. Оценка экспрессии генов SAD1 и SAD2 у всех исследованных сортов на всех изученных стадиях развития семени не выявила различий. Экспрессия генов десатуразы семейства FAD2 зависела от стадии развития семян. В течение изученного периода формирования семян уровень экспрессии был высоким, что указывает на интенсивность биосинтеза и накопления α-линоленовой и линолевой кислот. Экспрессия генов десатураз FAD3, контролирующего заключительный этап превращения ненасыщенных жирных кислот льна, незначительно зависела от времени после цветения. Выявлена пропорциональная зависимость содержания α-линоленовой кислоты в масле от уровня экспрессии генов десатураз FAD3. Полученные данные указывают на динамику в процессе метаболизма жирных кислот при формировании семян льна. Определена генотип-специфичность при оценке экспрессии десатураз семейства FAD в семенах льна масличного.

**Ключевые слова:** лен масличный, экспрессия, ПЦР, десатуразы, FAD, SAD, РНК, гель-электрофорез

## Dynamics of desaturase gene expression in the process of oil flax seed formation

✉ Bazanov T.A., Ushchapovsky I.V., Loginova N.N., Minina E.V., Veresova P.D.

Federal Research Center for Bast Fiber Crops

Tver, Russia

✉ e-mail: t.bazanov@fncl.ru

Oil flax (*Linum usitatissimum* L.) is a multi-purpose crop used in many industries. The composition of traditional flax seed oil varieties is characterized by a high content of desaturated Omega-3 fatty acids. In the process of lipid biosynthesis in the cell, an important step is the desaturation of fatty acids, which determines the final ratio of saturated and desaturated fatty acids in the oil. The main enzymes

that determine the efficiency of desaturation are membrane-bound desaturases (FADs) and soluble desaturases (SADs). The purpose of the work is to study the expression of desaturase genes in the process of seed development of different oilseed flax varieties. Eight varieties of oil flax with different fatty acid composition of oil served as the material for the study. The samples were grown in a plant chamber until flowering and on days 5, 10, 15, 20, 25, 30 and 35 after flowering, bolls were taken from the plants followed by RNA extraction from the seeds. Then reverse transcription and semi-quantitative RT-PCR were performed. The resulting reaction products were separated using a 1.2% agarose gel. The adenine phosphoribosyltransferase-1 (APT<sub>1</sub>) gene was used as a reference. As a result of the study, data were obtained on the expression of six flax desaturase genes: SAD1, SAD2, FAD2A, FAD2B, FAD3A and FAD3B. Evaluation of the expression of the SAD1 and SAD2 genes in all the studied varieties at all the studied stages of seed development did not find any differences. Expression of desaturase genes of the FAD2 family depended on the stage of seed development. During the studied period of seed formation, the expression level was high, indicating the intensity of biosynthesis and accumulation of  $\alpha$ -linolenic and linoleic acids. The expression of FAD3 desaturase genes, which control the final stage of the conversion of flax desaturated fatty acids, did not significantly depend on the time after flowering. A proportional dependence of the content of  $\alpha$ -linolenic acid in oil on the level of expression of the FAD3 desaturase genes was revealed. The data obtained indicate the dynamics in the metabolism of fatty acids during the formation of flax seeds. Genotype specificity was determined when assessing the expression of desaturases of the FAD family in oil flax seeds.

**Keywords:** oil flax, expression, PCR, desaturases, FAD, SAD, RNA, gel electrophoresis

**Для цитирования:** Базанов Т.А., Ущяповский И.В., Логинова Н.Н., Минина Е.В., Вересова П.Д. Динамика экспрессии генов десатуразы в процессе формирования семян масличного льна // Сибирский вестник сельскохозяйственной науки. 2024. Т. 54. № 10. С. 25–39. <https://doi.org/10.26898/0370-8799-2024-10-3>

**For citation:** Bazanov T.A., Ushchapovsky I.V., Loginova N.N., Minina E.V., Veresova P.D. Dynamics of desaturase gene expression in the process of oil flax seed formation. *Sibirskii vestnik sel'skokhozyaistvennoi nauki = Siberian Herald of Agricultural Science*, 2024, vol. 54, no. 10, pp. 25–39. <https://doi.org/10.26898/0370-8799-2024-10-3>

#### Конфликт интересов

Авторы заявляют об отсутствии конфликта интересов.

#### Conflict of interest

The authors declare no conflict of interest.

#### Благодарность

Работа выполнена при поддержке Минобрнауки РФ в рамках государственного задания ФГБНУ «Федеральный научный центр лубяных культур» (тема № FGSS-2024-0002).

#### Acknowledgments

The research was carried out under the support of the Ministry of Science and Higher Education of the Russian Federation within the state assignment of the Federal Research Center for Bast Fiber Crops (theme no. FGSS-2024-0002).

## INTRODUCTION

Oil flax (*Linum usitatissimum* L.) is a multipurpose crop cultivated for use in various industries—food, medical, and chemical. Flax is rightfully considered one of the leading oilseed crops, recognized worldwide for the high value of its oil, which is extracted from seeds through various mechanical and chemical methods [1]. Annually, 3–5 million hectares are sown with oil flax globally<sup>1</sup>. The Russian Federation is among

the top three global producers and exporters of oilseed flax seeds. In the last three years, the area under oilseed flax cultivation in Russia has ranged from 1.5 to 2.0 million ha<sup>2</sup>.

Oilseed flax seeds contain up to 50% oil, which has a unique composition of fatty acids—oleic acid (~24%), stearic acid (~4%), linoleic acid (~15%),  $\alpha$ -linolenic acid (~50%), and palmitic acid (~6%) [2, 3]. Flaxseed oil is particularly rich in  $\alpha$ -linolenic acid (ALA), an

<sup>1</sup>FAOSTAT: Food and Agriculture Organization of the United Nations. URL: <https://www.fao.org/faostat/en/?%23data/QL#home> (date of reference: 17.03.2024).

<sup>2</sup>Federal State Statistics Service. URL: <https://rosstat.gov.ru/> (date of reference: 22.03.2024).

essential omega-3 fatty acid [4, 5]. In the human body, ALA cannot be synthesized independently, and its deficiency can lead to various health problems. Therefore, ALA must be obtained externally through dietary supplements [3]. Additionally, ALA, together with linoleic acid, serves as a precursor for the synthesis of long-chain polyunsaturated fatty acids (eicosapentaenoic, docosapentaenoic, docosahexaenoic, and arachidonic acids), which play an important role in reducing total cholesterol levels and preventing chronic diseases, including cardiovascular, oncological, neurodegenerative, inflammatory, and other [3–7].

In addition to the production of edible oil, as well as a wide range of nutraceuticals and health food products [8], oil from oil flax is used in the production of biodiesel, various resins, plastics, varnishes, linoleum, oil-based and printing inks, and as a protective coating for wood and concrete [1, 9].

The high content of linolenic acid contributes to the high oxidation rate of flaxseed oil, which reduces its shelf life as a food product but simultaneously gives it unique drying properties essential for various industrial applications [6, 10].

The biosynthesis of fatty acids occurs in every plant cell and is one of the key metabolic pathways ensuring growth and development. When fatty acid biosynthesis is inhibited, any cell dies [11, 12].

Fatty acid desaturation is an essential biochemical process in which the key enzymes are desaturases, which are responsible for fatty acid biosynthesis in cells. They catalyze the conversion of a single bond (C-C) in the acyl chain into a double bond (C=C), which leads to the creation of unsaturated fatty acids from saturated ones [4–6].

Fatty acid desaturases are divided into two phylogenetically unrelated groups: membrane-bound (FAD) and soluble (SAD). Membrane-bound desaturases are part of plant cell membranes and are located in the endoplasmic

reticulum or other membrane organelles, whereas soluble desaturases are usually found in free form within the cell and are not associated with membrane structures. Both types of desaturases are specific to different fatty acids and control the balance of saturated and unsaturated fatty acids in plant cells, which affects oil composition and functionality [4, 5].

To date, desaturase genes have been studied in various plant species, including flax. Flax desaturases are encoded by duplicated genes. The soluble desaturase SAD genes play a key role in the conversion of stearyl-ACP to oleoyl-ACP by adding a double bond at the  $\Delta 9$  position. FAD2 genes, in turn, are responsible for the desaturation of oleic acid to linoleic acid, and FAD3 genes are involved in the conversion of linoleic acid to linolenic acid. Two major FAD3 gene isoforms have been identified in flax: FAD3A and FAD3B, which encode microsomal desaturases capable of desaturating linoleic acid. The study of desaturase gene isoforms is important from the point of view of breeding, as it may allow controlling the level of linolenic acid content in linseed oil at the genetic level<sup>3</sup> [13, 14].

The stepwise desaturation of fatty acids is an important stage in their biosynthesis, determining the ratio of saturated and unsaturated fatty acids in the oil. Based on this ratio, it is possible to determine the most appropriate direction for its utilization, either as a source of nutritional products useful for human metabolism or for industrial applications [12].

The study of the expression profile of desaturase genes will make it possible to assess the functional properties and genetic features that are necessary in controlling the process of lipid biosynthesis, creating new high-tech flax varieties with the required parameters.

In addition, genes expressed during seed formation have not been sufficiently studied in flax. Expanding this knowledge and analyzing the expression profiles of flax desaturase genes will help to assess their role in the formation of

<sup>3</sup>Thambugala D., Cloutier S. Fatty acid composition and desaturase gene expression in flax (*Linum usitatissimum* L.) // Journal of applied genetics. 2014. Vol. 55. P. 423–432. DOI: 10.1007/s13353-014-0222-0.

different types of fatty acids, allow a more detailed study of the key molecular and genetic mechanisms of oil biosynthesis in flax seeds, and identify key regulatory genes affecting the coordination and control of seed development processes. The study of desaturase gene expression will allow expanding the knowledge of flax biology and improving the processes of breeding and creating new varieties with desired characteristics [4].

The purpose of the study was to investigate the expression of desaturase genes during seed development of different oil flax varieties.

### MATERIAL AND METHODS

Experimental studies were carried out in the “Molecular-genetic research and cell selection” laboratory of the Federal Research Center for Bast Fiber Crops (“FRC BFC”) in 2024.

The material for the study of desaturase gene expression was eight varieties of oil flax obtained from the collection of the separate subdivision “Flax Institute” of the Federal Research Center for Bast Fiber Crops (Torzhok). The varieties were selected taking into account the degree of ALA content as one of the most valuable fatty acids. The list of varieties under study is presented in Table 1.

The studied flax varieties were grown in a growth chamber under the following conditions: temperature 22 °C and day/night photoperiod –

16/8 h. During plant development, individual flowers and bolls formed from them were noted. For molecular analysis, bolls were collected from plants on days 5, 10, 15, 20, 25, 30, and 35 after flowering (hereafter referred to as DAF) and RNA extraction was performed.

For RNA extraction, 0.2 g of seeds from each capsule of the corresponding variety were used. RNA extraction was performed using the column-based total RNA isolation kit for plant material “RNA-Xtrac Plants” (Biomedical Innovations LLC, Russia) according to the manufacturer's instructions. The quality of the isolated RNA was checked using spectrophotometric methods and by electrophoresis of RNA samples in a 1.5% agarose gel. The obtained RNA samples were treated with DNase before the reverse transcription step. cDNA synthesis was carried out using the “M-MuLV Reverse Transcriptase without RNase H Activity (RH-)” kit (Biolabmix, Russia) in accordance with the manufacturer's instructions.

To obtain RNA sequences, the UniProt interface was used. The obtained sequences were subjected to BLAST analysis against *L. usitatissimum* scaffolds using NCBI software. Gene-specific primers for PCR were designed using Primer3plus software, and their nucleotide sequences are presented in Table 2.

The principle of semi-quantitative RT-PCR is based on measuring the relative expression of

**Табл. 1.** Перечень сортообразцов льна масличного, использованных для исследования экспрессии генов десатураз

**Table 1.** List of linseed flax varieties used to study the expression of desaturase genes

Variety	Main fatty acid content, %		
	Oleinic	Linoleic	Linolenic
AGT 427/10	13,1	13,4	64,3
Vitagold	18,3	14,8	58,1
LM 91	23,8	19,4	47,0
AGT 1568/07	17,1	28,6	43,5
AGT 422/10	18,3	35,5	32,6
AGT 987/02	17,4	53,1	18,5
Yantar	15,3	66,8	8,3
Amon	14,8	71,8	3,1

target genes during the linear phase of the reaction<sup>4</sup>. In this PCR method, all studied cDNA samples are amplified with the same number of cycles, followed by separation via electrophoresis and staining using a specific dye (e.g., EtBr). As a result, the expression rate of the target gene can be assessed by measuring the intensity of the band corresponding to the formed amplicon. The band intensity reflects the number of copies of the target cDNA (i.e., target mRNA) at the start of PCR and, consequently, the level of expression of the target gene in the sample.

Semi-quantitative RT-PCR was performed in a T-100 thermocycler (BioRad) using the obtained cDNA samples corresponding to 5–35 days of sampling and RNA extraction. The reaction mixture for amplification contained 4 ng of cDNA, 1x PCR buffer, 1.5 mM MgCl<sub>2</sub>, 0.8 mM dNTP, 0.4 μM of each primer, and 1.5 units of Taq DNA polymerase. The first stage of amplification involved initial denaturation at 95 °C for 15 minutes; this was followed by 28 cycles of denaturation at 95 °C for 10 seconds, primer annealing at 62 °C for 10 seconds, and elongation at 72 °C for 10 seconds. The final stage was terminal elongation at 72 °C for 10 minutes. The use of 28 cycles is recommended in studies on gene expression<sup>5</sup> (see footnote 3).

The resulting amplicons were separated using a 1.2% agarose gel of 15 × 10 cm in TAE buffer pre-stained with ethidium bromide. Electrophoretic separation was performed for 2 h with an amperage of 200 mA. PCR products were quantified by fluorescence intensity scanning in UV light using a ChemiDoc MP gel documentation system (Bio-Rad, USA). Image Lab image analysis software version 6.0.1 (Bio-Rad, USA) was used to measure the signal strength of each amplified band.

The adenine phosphoribosyltransferase-1 (APT1) gene was used as a reference gene [15]. The expression of target desaturase genes was assessed relative to it by dividing the signal of the desaturase gene amplicon by the signal of APT1 gene. Independent replicate RT-PCR was performed in three replicates for each genotype, gene (including APT1), and plant developmental stage under study.

## RESULTS AND DISCUSSION

This study provides expression data for six flax desaturase genes SAD1, SAD2, FAD2A, FAD2B, FAD3A and FAD3B for eight flax accessions at seven stages of seed development.

Figure 1 shows an example of electrophoretic separation of cDNA amplification products of

**Табл. 2.** Нуклеотидные последовательности праймеров, использованных в полуколичественной RT-PCR

**Table 2.** Nucleotide sequences of primers used in semi-quantitative RT-PCR

Gene	Primer sequence, 5'→3'	
	Forward primer	Reverse primer
SAD1	TCGCAGCAGACGAGAAACG	AGGGTCGATCTCGAAGAGCTT
SAD2	AAGCTGGAGATCTTTAAGTCCCTT	GTTCGGGCAGGAAATCTTGT
FAD2A	CGTGGATCGAGACTACGGGTTA	ATGGTGCGCGACATGTGT
FAD2B	TGGCACTCAAAGTACCTCAACAA	AAGGCCAGCCGAGAGTGA
FAD3A	GACTTCAAACACTGTGGCTCT	GATAGCCACACCATTGGTGC
FAD3B	GCAGCGGTCTTGATTTCAACA	ATTTTGAGGACCGGAGCGAA
APT <sub>1</sub>	TAGAGCTGACCAGGACAAACA	GTTTATGAATGCGCTTGTCTCA

<sup>4</sup>Wang F. Semi-quantitative RT-PCR: An effective method to explore the regulation of gene transcription level affected by environmental pollutants. *Environmental Toxicology and Toxicogenomics: Principles, Methods, and Applications*, New York, NY: Springer US, 2021, pp. 95–103. DOI: 10.1007/978-1-0716-1514-0\_7.

<sup>5</sup>Kumar S., Jordan M. C., Datla R., Cloutier S. The LuWD40-1 gene encoding WD repeat protein regulates growth and pollen viability in flax (*Linum usitatissimum* L.) // *PLoS one*, 2013, vol. 8, N 7, p. e69124. DOI: 10.1371/journal.pone.0069124.

the FAD3A desaturase gene FAD3A cDNA of the AGT 422/10 strain and the APT<sub>1</sub> reference gene.

The expression levels and patterns of all the genes studied varied significantly. Thus, the genes SAD1 and SAD2 in all studied varieties showed almost identical profile, not differing in expression level between the varieties (see fig. 2, 3).

The oleic acid content in this sample of the varieties ranges from 13.1 to 23.8%, but the data obtained indicate that the fatty acid composition of flaxseed oil is practically unaffected by the genes of these desaturases.

FAD gene expression landscapes were compared for each of the cultivars studied (see fig. 4-11).

The variety AGT427/10 contains the highest amount of ALA (64.3%) in the oil of the studied samples and the lowest content of linoleic acid (13.4%). Comparison of the FAD gene expression profiles of this variety (see fig. 2) helps to explain this fatty acid composition. The expression of all four genes increases rapidly by day 10 after flowering, then decreases for the FAD2 genes on day 15. Meanwhile, for FAD2A, FAD3A, and FAD3B genes, the expression increases strongly by day 20, while for FAD2B, the expression increase is not significant at all, then the expression for all genes decreases smoothly. This suggests that in the seeds of cultivar AGT 427/10 from the very beginning of development there is an active simultaneous sequential conversion of oleic acid to linoleic acid and linoleic acid to ALA, mainly with the participation of de-

saturases determined by FAD2A, FAD3A, and FAD3B genes.

Comparison of FAD gene expression for the Vitagold cultivar also indicates some genotype-specificity of fatty acid metabolism. The landscape of FAD3 gene expression has a proportional angular profile with a maximum on the 20th day after flowering, while the maximum of FAD2 gene expression is shifted 5 days later. This indicates that despite the high level of FAD3 gene expression as in the previous cultivar, the ALA content in the oil of this cultivar will slightly decrease as a result of the shift of the maximum period of linoleic acid production, which is confirmed by the literature data for the Vitagold cultivar (58.1% ALA and 14.8% linoleic acid).

The expression landscape of FAD genes of LM 91 variety is generally similar to the data of Vitagold variety in terms of expression periods, but a characteristic decrease in the maximum for FAD3 genes and an increase in the maximum for FAD2 genes is noticeable. This is due to the fatty acid composition of the oil of this variety (47% ALA and 19.4% linoleic acid). The peak of FAD3B gene expression on the 30th day did not allow a decrease in ALA content in this cultivar. This point is confirmed when analyzing the FAD gene expression profiles of AGT 1568/07 variety AGT 1568/07.

The expression landscapes of the genes under consideration in cultivars LM 91 and AGT 1568/07 (43.5% ALA and 28.6% linoleic acid) are generally identical except for two positions: the presence of an additional maximum of FAD2B gene expression at day 10 and the absence of a second maximum of FAD3B gene expression at day 30, which explains the shift in the balance of LC composition. The data indicate that more linoleic acid produced at an early stage of seed development is not converted to ALA at later stages. The reasons for this cannot be established within the scope of this study.

The concentrations of ALA and linoleic acid in the oil of the AGT 422/10 variety are almost equilibrium, with 33% ALA and 36% linoleic acid. This is well described by the gene expres-

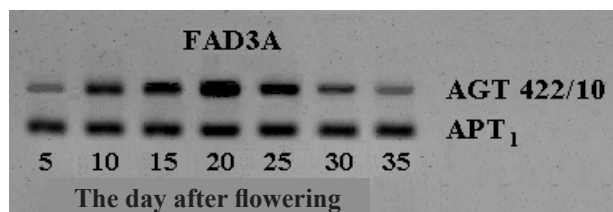

**Рис. 1.** Электрофоретическое разделение продуктов ПЦР кДНК гена десатураз FAD3A сорта AGT 422/10 и референсного гена APT<sub>1</sub>

**Fig. 1.** Electrophoretic separation of PCR products cDNA of the FAD3A desaturase gene of the AGT 422/10 variety and the reference gene APT<sub>1</sub>

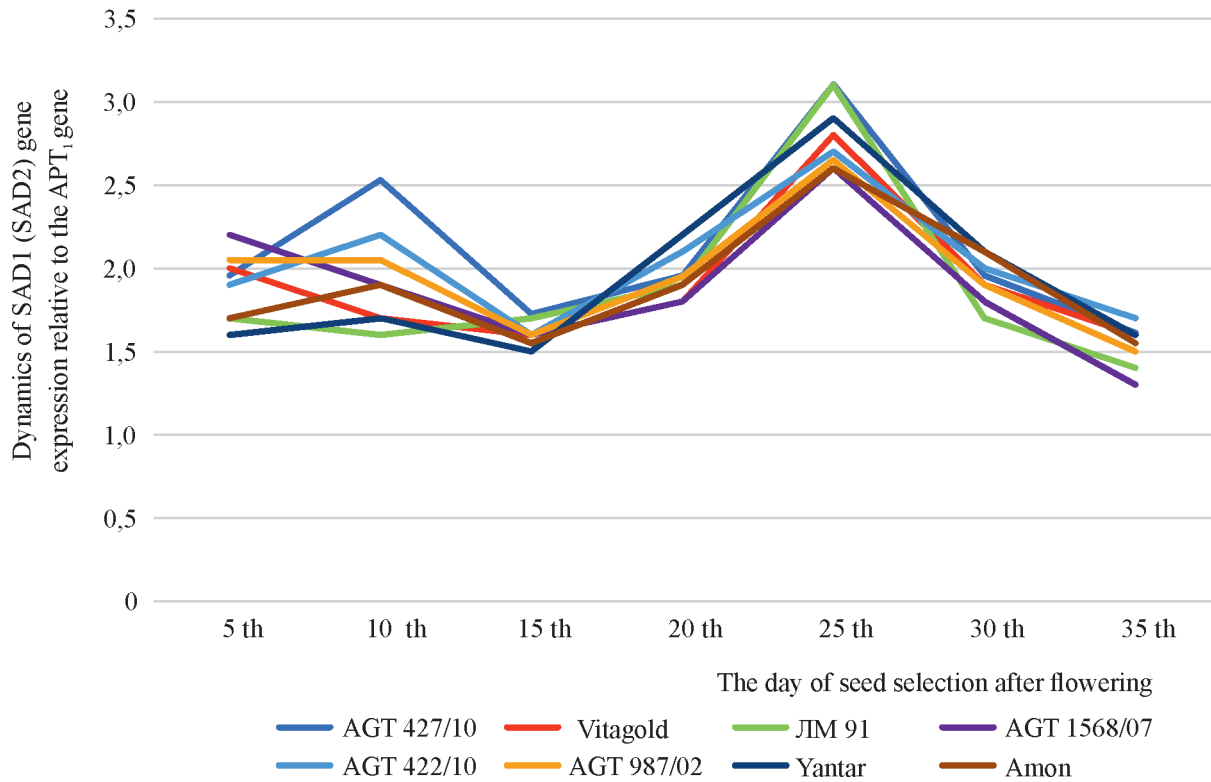

**Рис. 2.** Динамика экспрессии гена SAD1 относительно гена APT<sub>1</sub>

**Fig. 2.** Dynamics of SAD1 gene expression relative to the APT<sub>1</sub> gene

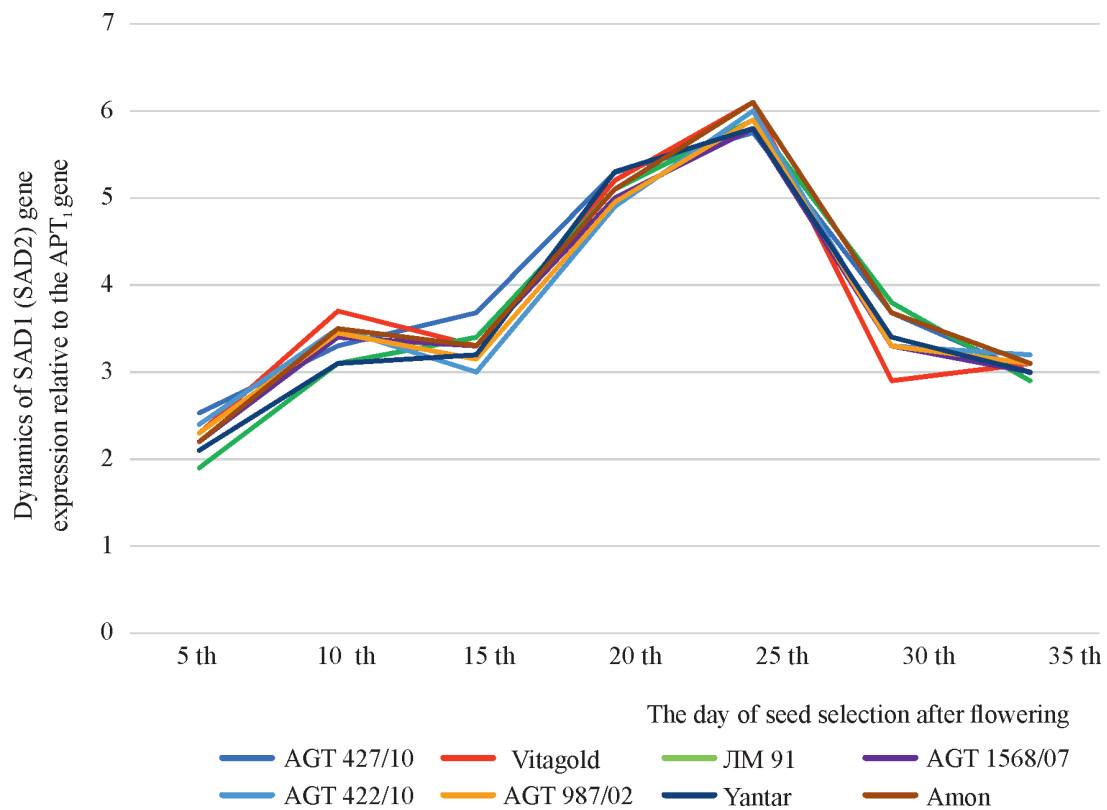

**Рис. 3.** Динамика экспрессии гена SAD2 относительно гена APT<sub>1</sub>

**Fig. 3.** Dynamics of SAD2 gene expression relative to the APT<sub>1</sub> gene

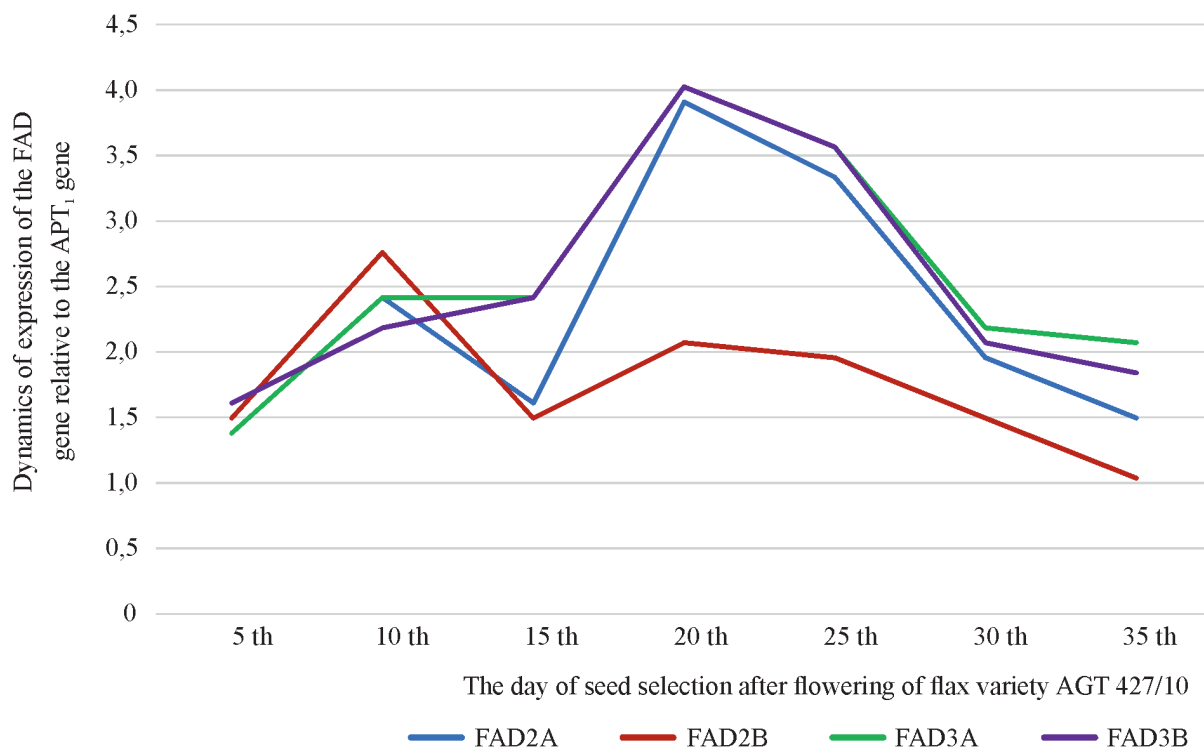

**Рис. 4.** Динамика экспрессии генов FAD2 и FAD3 сорта AGT 427/10 относительно гена APT<sub>1</sub>

**Fig. 4.** Dynamics of expression of the FAD2 and FAD3 genes of the AGT 427/10 variety relative to the APT<sub>1</sub> gene

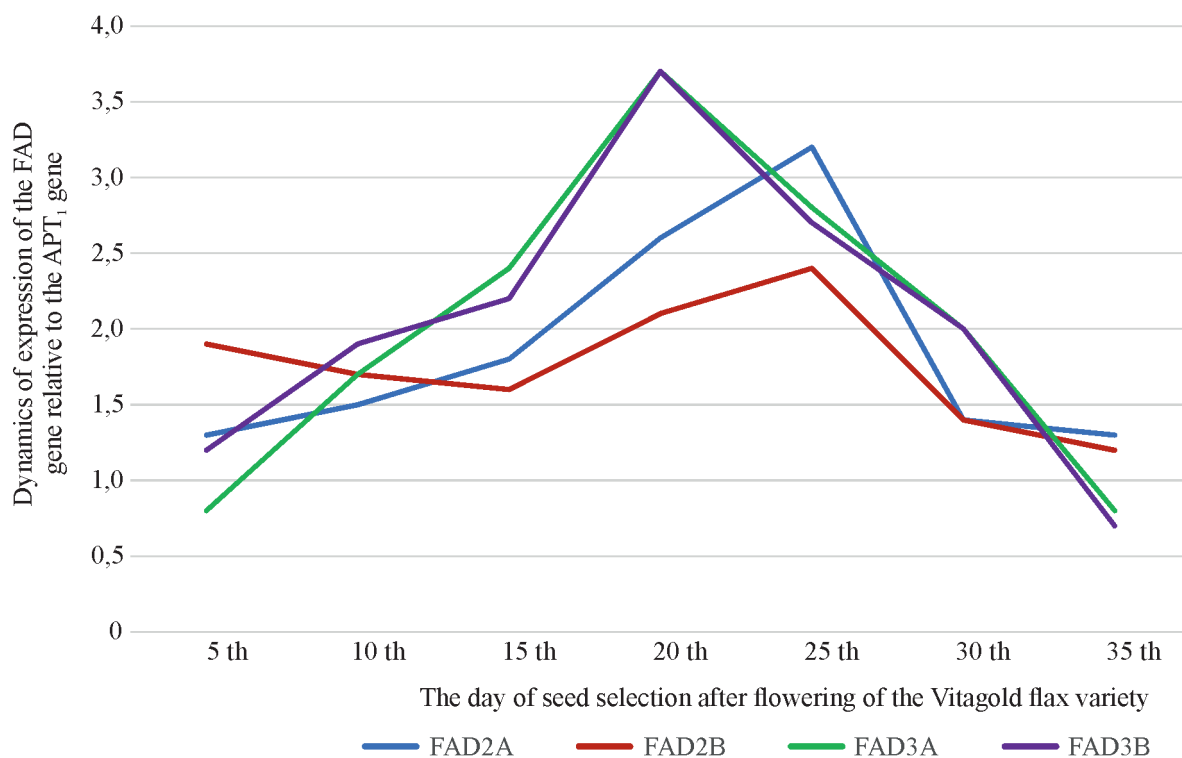

**Рис. 5.** Динамика экспрессии генов FAD2 и FAD3 сорта Витаголд относительно гена APT<sub>1</sub>

**Fig. 5.** Dynamics of expression of the FAD2 and FAD3 genes of the Vitagold variety relative to the APT<sub>1</sub> gene

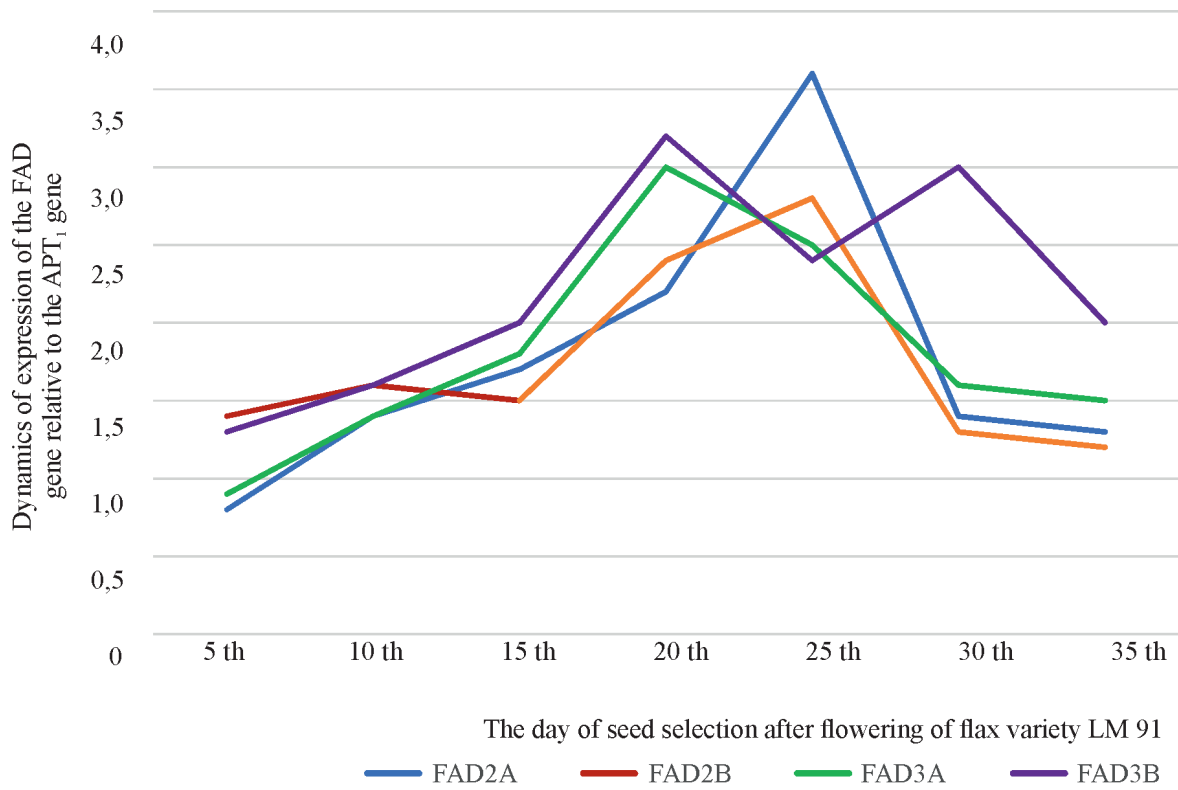

*Рис. 6.* Динамика экспрессии генов FAD2 и FAD3 сорта ЛМ 91 относительно гена APT<sub>1</sub>  
**Fig. 6.** Dynamics of expression of the FAD2 and FAD3 genes of the LM 91 variety relative to the APT<sub>1</sub> gene

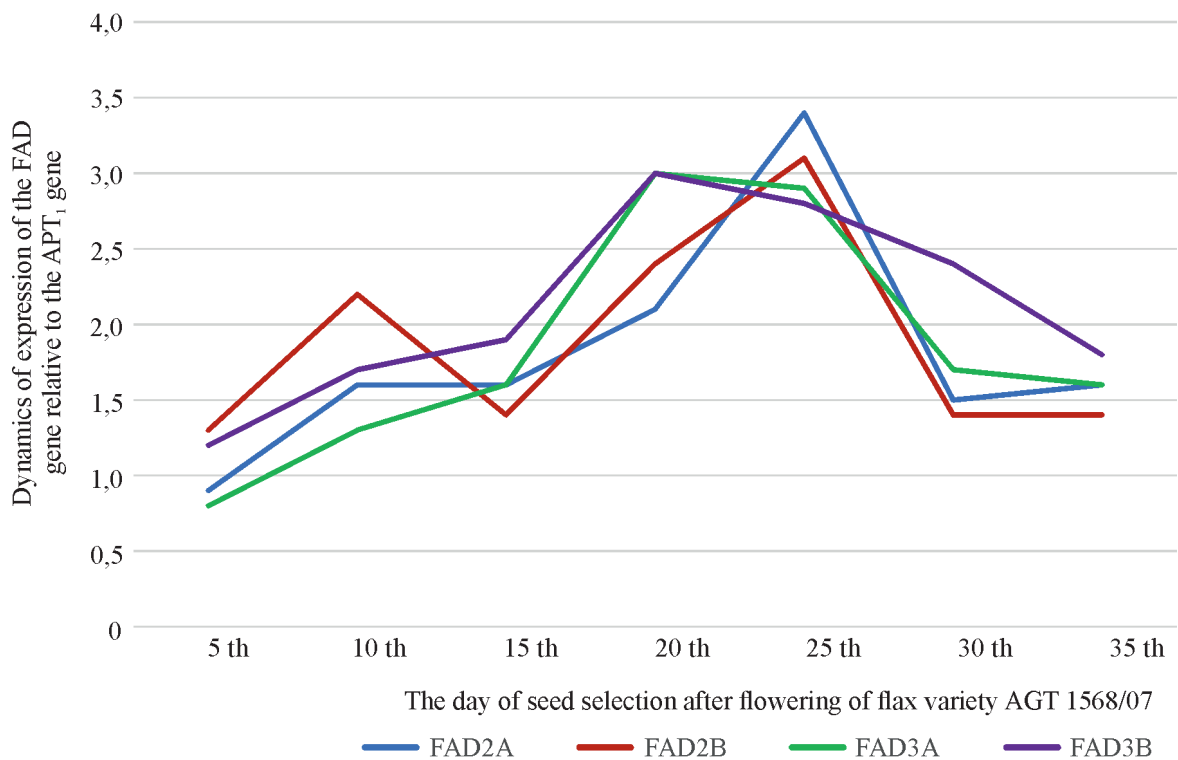

*Рис. 7.* Динамика экспрессии генов FAD2 и FAD3 сорта AGT 1568/07 относительно гена APT<sub>1</sub>  
**Fig. 7.** Dynamics of expression of the FAD2 and FAD3 genes of the AGT 1568/07 variety relative to the APT<sub>1</sub> gene

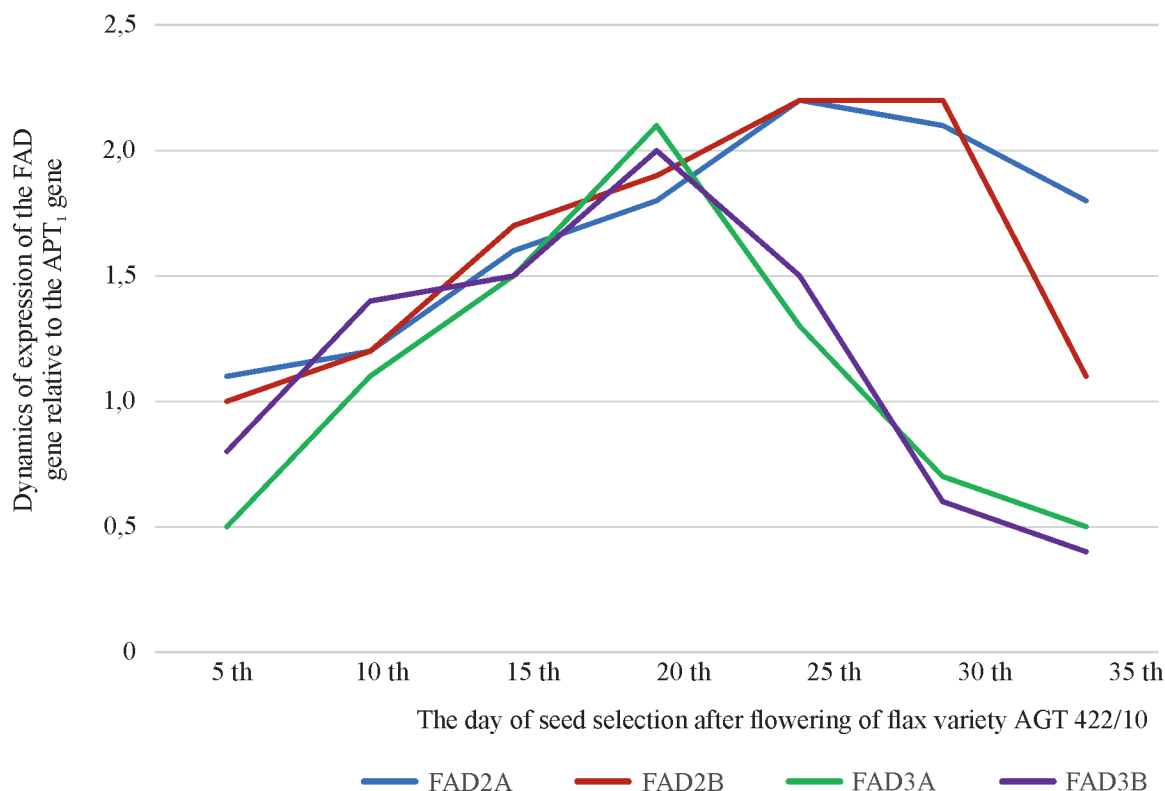

**Рис. 8.** Динамика экспрессии генов FAD2 и FAD3 сорта AGT 422/10 относительно гена APT<sub>1</sub>

**Fig. 8.** Dynamics of expression of the FAD2 and FAD3 genes of the AGT 422/10 variety relative to the APT<sub>1</sub> gene

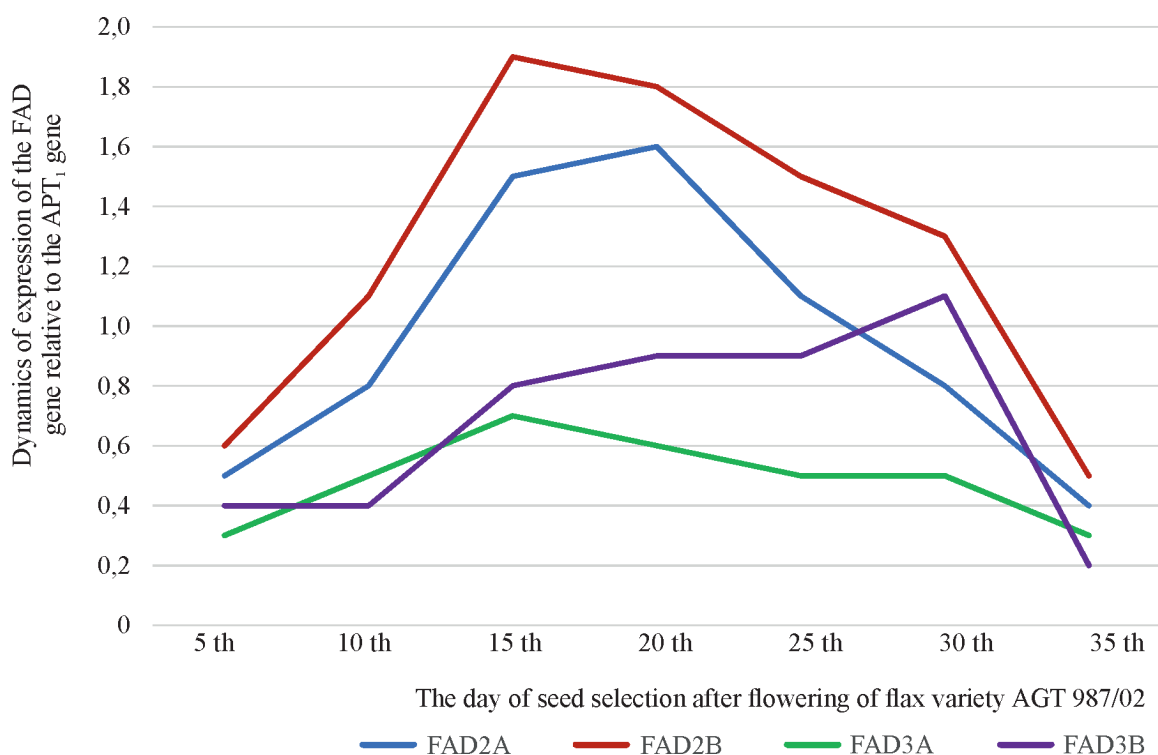

**Рис. 9.** Динамика экспрессии генов FAD2 и FAD3 сорта AGT 987/02 относительно гена APT<sub>1</sub>

**Fig. 9.** Dynamics of expression of the FAD2 and FAD3 genes of the AGT 987/02 variety relative to the APT<sub>1</sub> gene

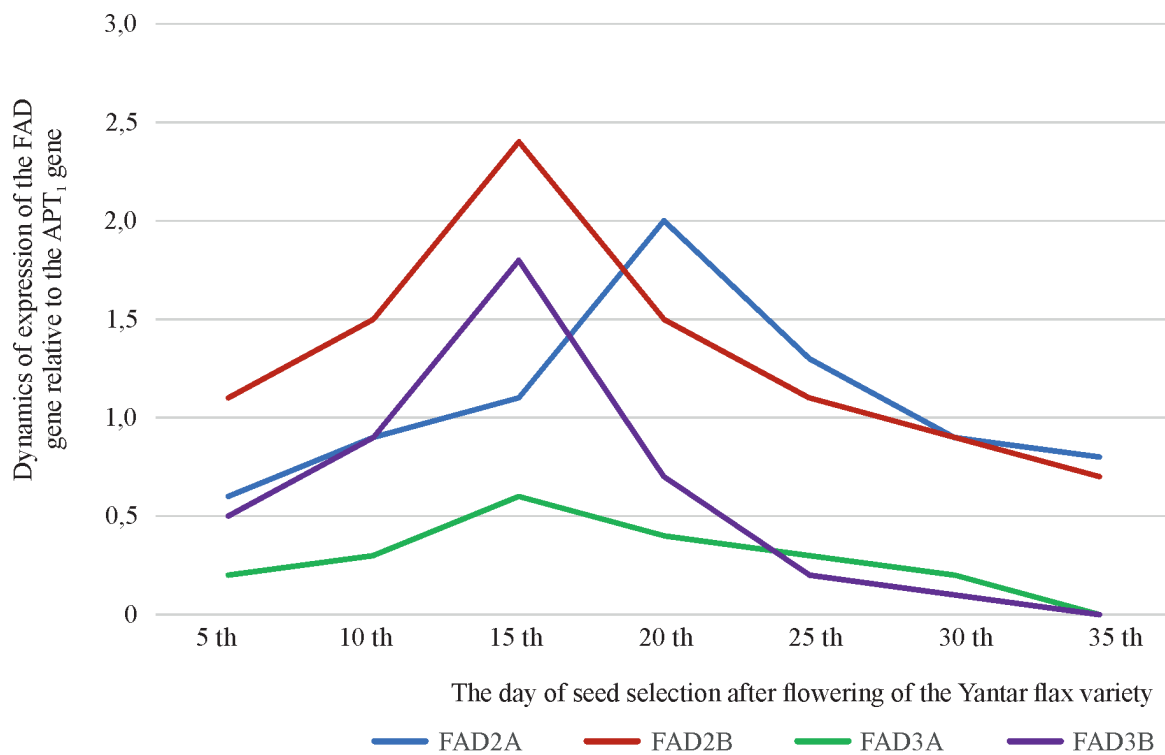

**Рис. 10.** Динамика экспрессии генов FAD2 и FAD3 сорта Янтарь относительно гена APT<sub>1</sub>

**Fig. 10.** Dynamics of expression of the FAD2 and FAD3 genes of the Yantar variety relative to the APT<sub>1</sub> gene

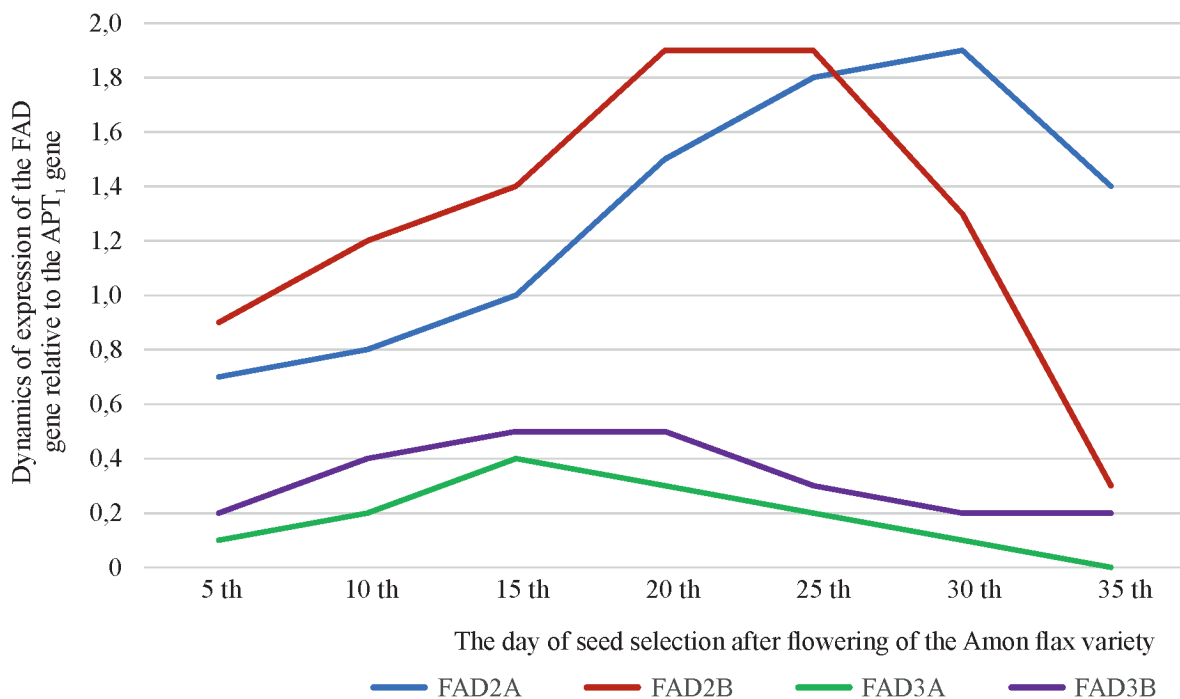

**Рис. 11.** Динамика экспрессии генов FAD2 и FAD3 сорта Амон относительно гена APT<sub>1</sub>

**Fig. 11.** Dynamics of expression of the FAD2 and FAD3 genes of the Amon variety relative to the APT<sub>1</sub> gene

sion landscape of both desaturases. The expression profile of FAD2 and FAD3 genes grows almost linearly until day 20, then FAD3 gene expression declines, and FAD2 continues to grow smoothly with a decline after day 30. Thus, up to the 20th day desaturases work synchronously, ALA synthesis takes place, then the concentration of FAD3 desaturases decreases and linoleic acid accumulation continues until the 35th day.

The expression profiles of FAD desaturases in the cultivar AGT 987/02 turned out to be very diverse. FAD2 genes showed the most pronounced expression of different strength but uniform profile. FAD3 genes were characterized by a low level of expression, and the expression of the FAD3A gene was quite insignificant. The expression of FAD3B gene smoothly increased up to the 30th day with subsequent decline. All this is characteristically reflected in the fatty acid composition of the oil (18.5% ALA and 53.1% linoleic acid), when the concentration of FAD2 desaturases begins to prevail, and the desaturation of linoleic acid and its conversion into ALA decreases.

The oil composition of the Yantar variety had a low content of ALA (8%) and a high content of linoleic acid (67%). Sufficiently high expression levels of FAD2A and FAD2B genes, whose profiles are characterized by the position of maxima (15th and 20th days, respectively), indicate periods of intensive linoleic acid production. At the same time, the FAD3B gene is also expressed quite intensively with a maximum at day 15, which should have increased linoleic acid conversion, but the strong decline in expression at day 20 of DPC does not allow for an increase in ALA concentration. The FAD3A gene is practically not expressed in this cultivar.

Amon is one of the lowest linolenic representatives of oilseed flax. The balance of fatty acids in its oil is almost completely shifted toward linoleic acid (8.3% ALA and 66.8% linoleic acid). The expression profiles of FAD genes in this case look expected: intensive prolonged expression of FAD2 genes and almost complete absence of FAD3 gene expression.

An important point in the study of FAD gene expression profiles in the varieties of this sample, which should be especially noted, is the gradual decrease in the intensity of FAD2 gene expression in the row from high-linolenic varieties to varieties with low ALA content. This decrease is characterized by a decrease in the conversion of oleic acid to linoleic acid. However, the concentration of oleic acid in the oil of the studied varieties is relatively stable. This may be due to changes in the intensity of expression of other genes of the FAD2 family.

## CONCLUSION

Desaturases play an important role in regulating the fatty acid composition of flax oil. The obtained data revealed the presence of dynamics in the process of fatty acid metabolism during the formation of flax seeds. Genotype specificity in assessing the expression of FAD family desaturases in flax seeds was determined.

The expression of desaturase genes of the FAD2 family in the studied period of seed formation was high and depended on the phase of seed formation. This largely determines the intensity of ALA and linoleic acid accumulation. The expression of FAD3 desaturase genes, which are the last enzyme group in the series of transformations of unsaturated fatty acids in flax, was less variable with respect to the time after flowering, but showed a proportional dependence of ALA content in oil on the expression level. Desaturases of the SAD family were practically not differentiated either by expression level or by development phase, which may be related to the relatively stable content of oleic acid in samples in the studied sample of oilseed flax varieties.

In general, assessment of oilseed flax desaturase gene expression in relation to time allows to increase the informativeness of data on genetic diversity of flax crop, to assess not only the levels of gene expression, but also their relationship with the phase of seed development.

## СПИСОК ЛИТЕРАТУРЫ

1. Markulin L., Makhno Y., Drouet S., Zare S., Anjum S., Tungmunnithum D., Sabzalian M.,

- Abbasi B.H., Lainé E., Levchuk H., Hano C. On “the most useful” oleaginous seeds: *Linum usitatissimum* L., a genomic view with emphasis on important flax seed storage compounds // *Oil Crop Genomics*. 2021. P. 135–157. DOI: 10.1007/978-3-030-70420-9\_8.
2. Поморова Ю.Ю., Овсенья С.К., Серова Ю.М. Химико-биологические свойства и потенциальная ценность семян масличного льна (обзор) // *Масличные культуры*. 2023. № 1 (193). С. 73–84. DOI: 10.25230/2412-608X-2023-1-193-73-84.
  3. Yang J., Wen C., Duan Y., Deng Q., Peng D., Zhang H., Ma H. The composition, extraction, analysis, bioactivities, bioavailability and applications in food system of flaxseed (*Linum usitatissimum* L.) oil: A review // *Trends in Food Science & Technology*. 2021. Vol. 118. P. 252–260. DOI: 10.1016/j.tifs.2021.09.025.
  4. Dmitriev A.A., Kezimana P., Rozhmina T.A., Zhuchenko A.A., Povkhova L.V., Pushkova E.N., Novakovskiy R.O., Pavelek M., Vladimirov G.N., Nikolaev E.N., Kovaleva O.A., Kostyukevich Yu.I., Chagovets V.V., Romanova E.V., Snezhkina A.V., Kudryavtseva A.V., Krasnov G.S., Melnikova N.V. Genetic diversity of SAD and FAD genes responsible for the fatty acid composition in flax cultivars and lines // *BMC Plant Biology*. 2020. Vol. 20. P. 1–12. DOI: 10.1186/s12870-020-02499-w.
  5. Pushkova E.N., Povkhova L.V., Dvorianinova E.M., Novakovskiy R.O., Rozhmina T.A., Gryzunov A.A., Sigova E.A., Zhernova D.A., Borkhert E.V., Turba A.A., Yablokov A.G., Bolshova N.L., Dmitriev A.A., Melnikova N.V. Expression of FAD and SAD genes in developing seeds of flax varieties under different growth conditions // *Plants*. 2024. Vol. 13. N 7. P. 956. DOI: 10.3390/plants13070956.
  6. Бражников В.Н., Бражникова О.Ф. Конкурсное сортоиспытание и жирнокислотный состав масла сортообразцов льна масличного (*Linum usitatissimum* L.) // *Международный сельскохозяйственный журнал*. 2020. № 2. С. 67–71. DOI: 10.24411/2587-6740-2020-12034.
  7. Al-Madhagy S., Ashmawy N.S., Mamdouh A., Eldahshan O.A., Farag M.A. A comprehensive review of the health benefits of flaxseed oil in relation to its chemical composition and comparison with other omega-3-rich oils // *European journal of medical research*. 2023. Vol. 28. N 1. P. 240. DOI: 10.1186/s40001-023-01203-6.
  8. Noreen S., Tufail T., Ul Ain H.B., Awuchi C.G. Pharmacological, nutraceutical, and nutritional properties of flaxseed (*Linum usitatissimum*): An insight into its functionality and disease mitigation // *Food Science & Nutrition*. 2023. Vol. 11. N 11. P. 6820–6829. DOI: 10.1002/fsn3.3662.
  9. Tang Z.X., Ying R.F., Lv B.F., Yang L.H., Xu Z., Yan L.Q., Wei Y.S. Flaxseed oil: extraction, health benefits and products // *Quality Assurance and Safety of Crops & Foods*. 2021. Vol. 13. N 1. P. 1–19. DOI: 10.15586/qas.v13i1.783.
  10. Brühl L., Bonte A., N'Diaye K., Matthäus B. Oxidation of Cyclo-Lino Peptides in Linseed Oils during Storage // *European Journal of Lipid Science and Technology*. 2022. Vol. 124. N 12. P. 2200137. DOI: 10.1002/ejlt.202200137.
  11. Miklaszewska M., Zienkiewicz K., Inhana P., Zienkiewicz A. Lipid metabolism and accumulation in oilseed crops // *OCL*. 2021. Vol. 28. P. 50. DOI: .1051/oc/2021039.
  12. Porokhovinova E.A., Matveeva T.V., Khafizova G.V., Bemova V.D., Doubovskaya A.G., Kishlyan N.V., Podolnaya L.P., Gavrilova V.A. Fatty acid composition of oil crops: genetics and genetic engineering // *Genetic Resources and Crop Evolution*. 2022. Vol. 69. N 6. P. 2029–2045. DOI: 10.1007/s10722-022-01391-w.
  13. Povkhova L.V., Melnikova N.V., Rozhmina T.A., Novakovskiy R.O., Pushkova E.N., Dvorianinova E.M., Zhuchenko A.A., Kamionskaya A.M., Krasnov G.S., Dmitriev A.A. Genes associated with the flax plant type (oil or fiber) identified based on genome and transcriptome sequencing data // *Plants*. 2021. Vol. 10. N 12. P. 2616. DOI: 10.3390/plants10122616.
  14. Cao S., Zhang J., Cheng H., Aslam M., Lv H., Dong W., Hu A., Guo M., Liu Q., Qin Y. Identification and evolutionary analysis of FAD2 gene family in green plants // *Tropical Plant Biology*. 2021. Vol. 14. P. 239–250. DOI: 10.1007/s12042-020-09276-x.
  15. Ma X., Gao Y., Ma X., Wu B., Yan B., Li Y., Wang Y., Xu P., Wen M., Wang H., Wang Y., Guo L. Effect of Different Types of Organic Manure on Oil and Fatty Acid Accumulation and Desaturase Gene Expression of Oilseed Flax in the Dry Areas of the Loess Plateau of China // *Agronomy*. 2024. Vol. 14. N 2. P. 381. DOI: 10.3390/agronomy14020381.

## REFERENCES

1. Markulin L., Makhno Y., Drouet S., Zare S., Anjum S., Tungmunnithum D., Sabzalian M., Abbasi B.H., Lainé E., Levchuk H., Hano C. On “the most useful” oleaginous seeds: *Linum usitatissimum* L., a genomic view with emphasis on important flax seed storage compounds. *Oil Crop Genomics*, 2021, pp. 135–157. DOI: 10.1007/978-3-030-70420-9\_8.
2. Pomorova Yu. Yu., Ovsepyan S.K., Serova Yu.M. Chemical and biological properties and potential value of oil flax seeds (review). *Maslichnye kul'tury = Oil crops*, 2023, vol. 1 (193), pp. 73–84. (In Russian). DOI: 10.25230/2412-608X-2023-1-193-73-84.
3. Yang J., Wen C., Duan Y., Deng Q., Peng D., Zhang H., Ma H. The composition, extraction, analysis, bioactivities, bioavailability and applications in food system of flaxseed (*Linum usitatissimum* L.) oil: A review. *Trends in Food Science & Technology*, 2021, vol. 118, pp. 252–260. DOI: 10.1016/j.tifs.2021.09.025.
4. Dmitriev A.A., Kezimana P., Rozhmina T.A., Zhuchenko A.A., Povkhova L.V., Pushkova E.N., Novakovskiy R.O., Pavelek M., Vladimirov G.N., Nikolaev E.N., Kovaleva O.A., Kostyukevich Yu.I., Chagovets V.V., Romanova E.V., Snezhkina A.V., Kudryavtseva A.V., Krasnov G.S., Melnikova N.V. Genetic diversity of SAD and FAD genes responsible for the fatty acid composition in flax cultivars and lines. *BMC Plant Biology*, 2020., vol. 20, pp. 1–12. DOI: 10.1186/s12870-020-02499-w.
5. Pushkova E.N., Povkhova L.V., Dvorianinova E.M., Novakovskiy R.O., Rozhmina T.A., Gryzunov A.A., Sigova E.A., Zhernova D.A., Borkherth E.V., Turba A.A., Yablokov A.G., Bolshova N.L., Dmitriev A.A., Melnikova N.V. Expression of FAD and SAD genes in developing seeds of flax varieties under different growth conditions. *Plants*, 2024, vol. 13, no. 7, p. 956. DOI: 10.3390/plants13070956.
6. Brazhnikov V.N., Brazhnikova O.F. Competitive variety and fatty-acid composition of oil of variety of flax flax (*Linum usitatissimum* L.). *Mezhdunarodnyi sel'skokhozyaistvennyi zhurnal = International Agricultural Journal*, 2020, vol. 2, pp. 67–71. (In Russian). DOI: 10.24411/2587-6740-2020-12034.
7. Al-Madhagy S., Ashmawy N.S., Mamdouh A., Eldahshan O.A., Farag M.A. A comprehensive review of the health benefits of flaxseed oil in relation to its chemical composition and comparison with other omega-3-rich oils. *European journal of medical research*, 2023, vol. 28, no. 1, p. 240. DOI: 10.1186/s40001-023-01203-6.
8. Noreen S., Tufail T., Ul Ain H.B., Awuchi C.G. Pharmacological, nutraceutical, and nutritional properties of flaxseed (*Linum usitatissimum*): An insight into its functionality and disease mitigation. *Food Science & Nutrition*, 2023, vol. 11, no. 11, pp. 6820–6829. DOI: 10.1002/fsn3.3662.
9. Tang Z.X., Ying R.F., Lv B.F., Yang L.H., Xu Z., Yan L.Q., Wei Y.S. Flaxseed oil: extraction, health benefits and products. *Quality Assurance and Safety of Crops & Foods*, 2021, vol. 13, no. 1, pp. 1–19. DOI: 10.15586/qas.v13i1.783.
10. Brühl L., Bonte A., N'Diaye K., Matthäus B. Oxidation of Cyclo-Lino Peptides in Linseed Oils during Storage. *European Journal of Lipid Science and Technology*, 2022, vol. 124, no. 12, p. 2200137. DOI: 10.1002/ejlt.202200137.
11. Miklaszewska M., Zienkiewicz K., Inchana P., Zienkiewicz A. Lipid metabolism and accumulation in oilseed crops. *OCL*, 2021, vol. 28, p. 50. DOI: 10.1051/ocl/2021039.
12. Porokhovina E.A., Matveeva T.V., Khafizova G.V., Bemova V.D., Doubovskaya A.G., Kishlyan N.V., Podolnaya L.P., GavriloVA V.A. Fatty acid composition of oil crops: genetics and genetic engineering. *Genetic Resources and Crop Evolution*, 2022, vol. 69, no. 6, pp. 2029–2045. DOI: 10.1007/s10722-022-01391-w.
13. Povkhova L.V., Melnikova N.V., Rozhmina T.A., Novakovskiy R.O., Pushkova E.N., Dvorianinova E.M., Zhuchenko A.A., Kamionskaya A.M., Krasnov G.S., Dmitriev A.A. Genes associated with the flax plant type (oil or fiber) identified based on genome and transcriptome sequencing data. *Plants*, 2021, vol. 10., no. 12, p. 2616. DOI: 10.3390/plants10122616.
14. Cao S., Zhang J., Cheng H., Aslam M., Lv H., Dong W., Hu A., Guo M., Liu Q., Qin Y. Identification and evolutionary analysis of FAD2 gene family in green plants. *Tropical Plant Biology*, 2021, vol. 14, pp. 239–250. DOI: 10.1007/s12042-020-09276-x.
15. Ma X., Gao Y., Ma X., Wu B., Yan B., Li Y., Wang Y., Xu P., Wen M., Wang H., Wang Y., Guo L. Effect of Different Types of Organic Manure on Oil and Fatty Acid Accumulation and Desaturase Gene Expression of Oilseed Flax in the Dry Areas of the Loess Plateau of China. *Agronomy*, 2024, vol. 14, no. 2, p. 381. DOI: 10.3390/agronomy14020381.

---

## ИНФОРМАЦИЯ ОБ АВТОРАХ

✉ **Базанов Т.А.**, кандидат химических наук, заведующий лабораторией, ведущий научный сотрудник; **адрес для переписки:** Россия, 170041, Тверь, Комсомольский проспект, 17/56; e-mail: t.bazanov@fncl.k.ru

**Ущাপовский И.В.**, кандидат биологических наук, ведущий научный сотрудник

**Логинова Н.Н.**, научный сотрудник

**Минина Е.В.**, младший научный сотрудник, аспирант

**Вересова П.Д.**, младший научный сотрудник

## AUTHOR INFORMATION

✉ **Taras A. Bazanov**, Candidate of Science in Chemistry, Laboratory Head, Lead Researcher; **address:** 17/56, Komsomolsky Prospect, Tver, 170041, Russia; e-mail: t.bazanov@fncl.k.ru

**Igor V. Ushapovsky**, Candidate of Science in Biology, Lead Researcher

**Natalya N. Loginova**, Researcher

**Ekaterina V. Minina**, Junior Researcher, Post-graduate Student

**Polina D. Veresova**, Junior Researcher

*Дата поступления статьи / Received by the editors 15.07.2024*  
*Дата принятия к публикации / Accepted for publication 16.08.2024*  
*Дата публикации / Published 20.11.2024*

## Засоренность посевов риса, возделываемого по разным предшественникам при периодических поливах в условиях Нижнего Поволжья

Родин К.А., ✉ Небезина А.Б.

*Всероссийский научно-исследовательский институт орошаемого земледелия – филиал Федерального научного центра гидротехники и мелиорации им. А.Н. Костякова*  
Волгоград, Россия  
✉ e-mail: aina.kanaeva@mail.ru

Изучены способы снижения затрат воды в наиболее водозатратном секторе сельскохозяйственного производства, связанного с орошением риса. Он в орошаемой земледелии относится к доминантной и самой водозатратной культуре. Представлены экспериментальные данные по засоренности посевов риса, орошаемого периодическими поливами, в зависимости от предшествующих культур. Ежегодно сорняки засоряют сельскохозяйственные посева, что ведет к значительному снижению урожая и его качества. Результаты исследования позволяют определить видовой состав сорных растений и меры борьбы с ними посредством обработки посевов риса баковой смесью гербицидов. Установлено суммарное водопотребление культуры по разным предшественникам. В результате наблюдений выявлены основные виды сорняков, в состав которых входили: щирица запрокинутая, ежовник (куриное просо), вьюнок полевой и другие представители сорной растительности. В борьбе с сорной растительностью использовали почвенный гербицид Стомп (6,0 л/га) в сочетании с обработкой по вегетации растений риса баковой смесью гербицидов Камбио (2,5 л/га) + Топик (0,5 л/га), растворенных в 200 л воды. Также в работе указаны данные по структурным показателям растений риса по разным предшественникам, что позволило установить фактическую урожайность. В результате полученных данных установлено, какой предшественник является эффективным как для снижения засоренности посевов, так и для получения наибольшей урожайности растений риса по вариантам опыта.

**Ключевые слова:** рис, периодическое орошение, сорняки, предшественники, урожайность

## Weediness of rice crops cultivated on different forecrops under periodic irrigation in the Lower Volga region conditions

Rodin K.A., ✉ Nevezhina A.B.

*All-Russian Research Institute of Irrigated Agriculture – Branch of the Federal Scientific Center for Hydraulic Engineering and Land Reclamation named after A. N. Kostyakov*  
Volgograd, Russia  
✉ e-mail: aina.kanaeva@mail.ru

The ways to reduce water inputs in the most water-intensive sector of agricultural production related to rice irrigation have been studied. In irrigated agriculture, it is the dominant and most water-intensive crop. Experimental data on weediness of rice crops irrigated with intermittent waterings depending on the preceding crops are presented. Every year weeds infest agricultural crops leading to a significant reduction in yields and crop quality. The results of the study make it possible to determine the species composition of weeds and weed control measures through the treatment of rice crops with a tank mixture of herbicides. Total water consumption of the crop by different forecrops has been determined. As a result of the observations, the main weed species have been identified, which included the following weed species: redroot amaranth, barnyard grass (prickly grass), corn bindweed and other representatives of the weedy vegetation. Soil herbicide Stomp (6.0 l/ha) was used in combination with treatment of the rice plants with a tank mixture of Cambio (2.5 l/ha) + Topik (0.5 l/ha) herbicides dissolved in 200 liters of water. Also in the work, the data on structural indices of rice plants on different forecrops are indicated, which allowed to establish the actual yield. As a result of the data obtained, it was established what forecrop is effective both for reducing weediness of crops and obtaining the highest yield of the rice plants in the variants of the experiment.

**Keywords:** rice, periodic irrigation, weeds, forecrops, yield

**Для цитирования:** Родин К.А., Небезина А.Б. Засоренность посевов риса, возделываемого по разным предшественникам при периодических поливах в условиях Нижнего Поволжья // Сибирский вестник сельскохозяйственной науки. 2024. Т. 54. № 10. С. 40–47. <https://doi.org/10.26898/0370-8799-2024-10-4>

**For citation:** Rodin K.A., Nevezhina A.B. Weediness of rice crops cultivated on different forecrops under periodic irrigation in the Lower Volga region conditions. *Sibirskii vestnik sel'skokhozyaistvennoi nauki = Siberian Herald of Agricultural Science*, 2024, vol. 54, no. 10, pp. 40–47. <https://doi.org/10.26898/0370-8799-2024-10-4>

#### Конфликт интересов

Авторы заявляют об отсутствии конфликта интересов.

#### Conflict of interest

The authors declare no conflict of interest.

## BINTRODUCTION

Rice is a valuable grain crop grown mainly according to the technology of basin flooding. This technology of rice cultivation requires large expenditures of irrigation water, which leads to additional financial costs, requires today the search for solutions to new problems in order to preserve water resources and ecological and sanitary condition of crops [1-3]. At the present stage, due to the shortage of fresh water not only in the Russian Federation, but also globally, there is a need to develop water-saving technologies for cultivation of agricultural crops, including rice [4, 5].

The All-Russian Research Institute of Irrigated Agriculture has developed a water-saving technology of rice irrigation, which saves irrigation water 3-5 times more compared to the traditional method of rice cultivation by flooding. This technology does not require the construction of specialized rice irrigation systems, but allows rice cultivation on general-purpose lands [6, 7].

In the conditions of the Krasnodar region, 8-field rice rotation, with more than 50% of the rice crop, was considered the best. The degree of saturation of rice crop rotations with perennial grasses with the mandatory inclusion of intermediate crops is currently relevant. Such a combination of rice rotation crops allows saturating the soil with fresh organic matter, obtaining consistently high yields of other crops and increasing rice yields without worsening the fertility of

arable lands [8–11].

Agrotechnical role of clean and occupied fallows, annual fallow crops and perennial grasses as the main forecrops in reducing the weediness of rice crops cultivated under flood irrigation, as well as their impact on yields has been the subject of many scientific works [12, 13]. According to the results of these works it was established that the main forecrops of rice are perennial legumes, seeded fallow with legume-grass crops, green-manured fallow, as well as intermediate crops [14, 15].

The problem of weediness of rice crops irrigated by periodic irrigation is not quite solved and is urgent at present. When cultivating rice under the technology of periodic irrigation as a forecrop can serve both row crops and continuous crops. Therefore, we selected such crops as soybean, potato and rice as forecrop for rice irrigated with intermittent irrigation in order to assess the impact on weed reduction and yield increase [16].

## MATERIAL AND METHODS

The studies were conducted from 2018 to 2020 with a systematic arrangement of predecessors. The soil water regime was maintained at no less than 80% of minimum water capacity (MWC) in the 0.4 –meter soil layer. The irrigation method used was drip irrigation (see fig. 1).

Soil moisture was determined by thermostat-weight method by layers through 0.1 m to a depth of 0.6 m. Evapotranspiration was calculated by water balance method according to

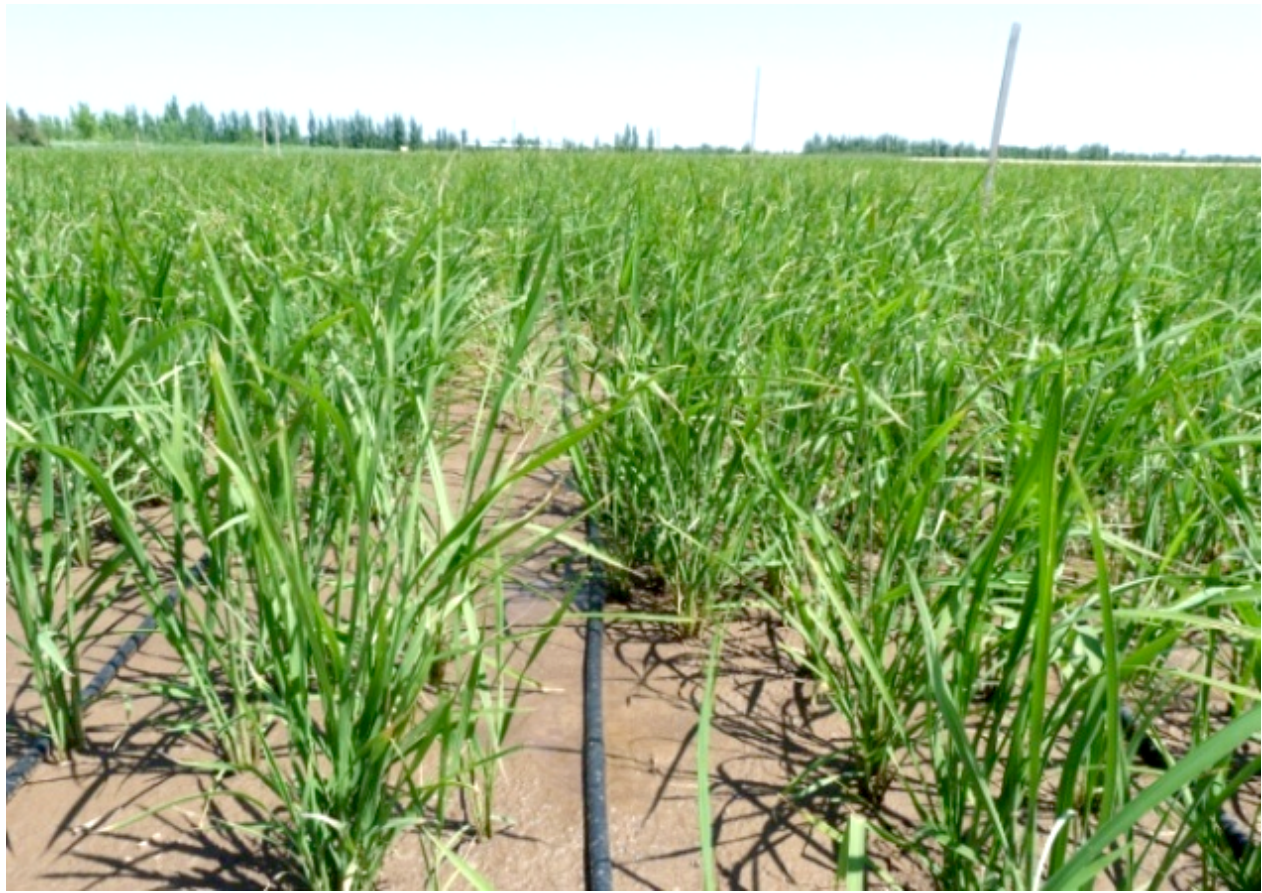

**Рис. 1.** Капельное орошение риса  
**Fig. 1.** Rice drip irrigation

the formula of A.N. Kostyakov<sup>1</sup>. Irrigation rates, taking into account the peculiarities of drip irrigation, were determined according to the equation of I.P. Kruzhilin, E.A. Khodyakov et al.<sup>2</sup> Water consumption coefficient, water consumption for formation of one ton of yield ( $K_v$ ,  $m^3/t$ ) was calculated according to the formula of A.N. Kostyakov<sup>3</sup>. Mineral fertilizers were calculated using the balance method of nutrient replacement according to the method of V.I. Filin<sup>4</sup>. Weediness of the crop was taken into account in the phase of 2–3 leaves by the method of projective coverage according to the recommended method of G.F. Nikitenko<sup>5</sup>.

In the fight against weeds, soil herbicide Stomp was used without incorporation into the soil at a dose of 6.0 liters/ha, dissolved in 200 liters of water. A tank mixture of herbicides Cambio (2.5 l/ha) + Topik (0.5 l/ha) dissolved in the recommended volume of water was applied against single and dicotyledonous weeds in the phase of 2–3 leaves of rice.

Mineral fertilizers were applied to the planned yield of 5 t/ha on the soybean forecrop –  $N_{68}P_{62}K_{75}$ , on the potato and rice forecrop –  $N_{95}P_{62}K_{75}$ , according to the methodological recommendations.

The seeding rate of rice plants was 5 million germinated seeds/ha.

1 Kostyakov A.N. Fundamentals of land reclamation. Moscow: Selkhozgiz, 1960, 621 p.

2 Patent No. 2204241 of the Russian Federation. Method of determination of irrigation rates at drip irrigation of tomatoes / I.P. Kruzhilin, E.A. Khodiakov, Y.I. Kruzhilin, A.M. Saldaev, A.V. Galda. 20.05.2003.

3 Kostyakov A.N. Selected works. Moscow: Selkhozgiz, 1961, vol. 1, 2, 807 p., 743 p.

4 Filin V.I. Reference book on crop production with the basics of yield programming. Volgograd: VGSKhA, 1994, 274 p.

5 Nikitenko G.F. Experimental work in field farming. Moscow: Rosselhozizdat, 1982, 190 p.

## RESULTS AND DISCUSSION

It is important to note that the studied forecrops did not have a noticeable effect on the change in the numerical value of the irrigation rate, which, according to the research data, remained constant throughout one growing season. However, the forecrops had varying effects on the contribution of soil moisture to meeting the water requirements of rice. This means that rice plants use soil moisture differently depending on the forecrop. For instance, the maximum difference between the water reserves in the 0.4-meter soil layer before rice sowing and the water reserves in the soil before harvesting was observed in the variant with soybean as the forecrop.

Over the three-year period, the total water consumption of rice under different forecrops ranged from 5,510 to 5,885 m<sup>3</sup>/ha. The maximum irrigation water requirement was observed for rice plants following the soybean forecrop, averaging 5,835 m<sup>3</sup>/ha. The lowest water consumption was recorded in the variant with rice

as the forecrop, averaging 5,570 m<sup>3</sup>/ha (see Table 1).

As a result of observations, the composition of the main weeds in rice crops irrigated with periodic watering was determined. It included the following weeds: the annual dicotyledonous redroot pigweed (*Amaranthus retroflexus* L.), the annual monocotyledonous barnyard grass (*Echinochloa crus-galli*), and the perennial root-sucker field bindweed (*Convolvulus arvensis*) (see Fig. 2).

Weed estimation before treatment with a tank mixture of herbicides showed that the maximum number of weeds was present in the variant with rice following the potato forecrop (67 plants/m<sup>2</sup>), while the number of weeds was slightly lower in the variant with rice following the rice forecrop (66 plants/m<sup>2</sup>). The minimum number of weeds (48 plants/m<sup>2</sup>) was observed in the variant with soybean as the forecrop. Fourteen days after treating the rice crops with a tank mixture of the herbicides Cambio and Topik, the weed population significantly decreased across

**Табл. 1.** Суммарное водопотребление риса по разным предшественникам, м<sup>3</sup>/га

**Table 1.** Total rice water consumption for various forecrops, m<sup>3</sup>/ha

Year of research	Irrigation norm	Atmospheric moisture used by plants	Soil moisture used by plants	Total water consumption
<i>Soy</i>				
2018	4810	495	450	5755
2019	3970	1475	440	5885
2020	3600	1760	506	5866
Average	4127	1243	465	5835
<i>Potato</i>				
2018	4810	495	295	5600
2019	3970	1463	293	5726
2020	3600	1758	343	5701
Average	4127	1239	310	5676
<i>Rice</i>				
2018	4810	495	205	5510
2019	3970	1431	211	5612
2020	3600	1754	231	5585
Average	4127	1227	216	5570



**Рис. 2.** Сорные растения в посевах риса:

*а* – однолетний однодольный ежовник (куриное просо) (*Echinochloa crus-galli*); *б* – однолетняя двудольная щирица запрокинутая (*Amaranthus retroflexus*); *в* – многолетний корнеотпрысковый вьюнок полевой (*Convolvulus arvensis*)

**Fig. 2.** Weed plants in rice crops:

*a*– annual monocotyledonous barnyard grass (prickly grass) (*Echinochloa crus-galli*); *b* – annual dicotyledonous redroot amaranth (*Amaranthus retroflexus*); *v* – perennial sobole corn bindweed (*Convolvulus arvensis*)

almost all forecrops, ranging from 1 to 2 plants/m<sup>2</sup> (see Table 2).

The application of herbicides contributed to a reduction in the number of weeds in the rice crops. Before harvesting, the overall weed infestation across the experimental variants ranged from 4 to 9 plants/m<sup>2</sup>.

tation across the experimental variants ranged from 4 to 9 plants/m<sup>2</sup>.

Analysis of the data shows that the degree of weed infestation in rice crops affects structural indicators and, consequently, its productivity (see Table 3).

**Табл. 2.** Количество основных видов сорняков в посевах риса по разным предшественникам с учетом обработки гербицидами (среднее по годам исследований, шт./м<sup>2</sup>.)

**Table 2.** Number of main weed species in rice crops on different forecrops with regard to herbicide treatment (average over the years of research, pcs. /m<sup>2</sup>)

Weed	Forecrop								
	soy			potato			rice		
	Before herbicide treatment	14 days after herbicide treatment	Before harvesting	Before herbicide treatment	14 days after herbicide treatment	Before harvesting	Before herbicide treatment	14 days after herbicide treatment	Before harvesting
Redroot pigweed ( <i>Amaranthus retroflexus</i> L.)	29	0	2	45	0	4	40	0	4
Barnyard grass ( <i>Echinochloa crus-galli</i> )	18	0	1	20	1	4	24	0	3
Root-sucker field bindweed ( <i>Convolvulus arvensis</i> )	1	1	1	2	1	1	2	2	2
Total weediness	48	1	4	67	2	5	66	2	9

**Табл. 3.** Элементы структуры урожая риса по разным предшественникам (средние значения по годам исследований)

**Table 3.** Elements of rice yield structure by different forecrops (average values by years of research)

Forecrop	Plant stand density, pcs./m <sup>2</sup>	Productive bushiness	Main panicle		Side panicle		Weight of 1000 grains, g	Yield, t/ha
			Number of grains, pcs.	Grain weight, g	Number of grains, pcs.	Grain weight per panicle, g		
Rice	248	1,5	38	1,38	31	0,52	27,5	4,92
Potato	251	1,5	39	1,39	31	0,57	28,5	5,06
Soy	253	1,6	39	1,41	32	0,68	29,8	5,09
LSD <sub>0,5</sub>	1,06	0,02	0,02	0,09	0,02	0,06	0,04	0,07

Thus, the maximum yield (5.09 t/ha) was achieved in the variant where rice followed the soybean forecrop, where the total number of weeds was the lowest compared to other forecrops. The plant density of rice in this forecrop variant was 253 plants/m<sup>2</sup>, the productive tillering was 1.6, and the weight of 1000 grains was 29.8 g.

## CONCLUSION

As a result of the research, the main types of weeds infesting rice crops (barnyard grass, red-root pigweed, and field bindweed) were identified. Their maximum number at the time of estimation after the application of the herbicide Stomp (6.0 L/ha) was 67 plants/m<sup>2</sup>. After treating the rice crops at the 2–3 leaf stage with a tank mixture of the herbicides Cambio (2.5 L/ha) + Topik (0.5 L/ha), the weed infestation decreased, and the total number of weeds at harvest ranged from 4 to 9 plants/m<sup>2</sup>.

Reduction in weed infestation in periodically irrigated rice crops was observed in the variant where rice followed the soybean forecrop, contributing to the formation of the highest yield (5.09 t/ha) compared to the potato and rice forecrops".

## СПИСОК ЛИТЕРАТУРЫ:

1. Зеленский П.Г., Зеленская О.В. Оценка эколого-экономической эффективности ресурсосберегающей и природосберегающей технологий возделывания риса // Рисоводство. 2021. № 4 (53). С. 17–22. DOI: 10.33775/1684-2464-2021-53-4-17-22.

2. Гераськина Т.В., Бандурин М.А., Приходько И.А. Совершенствование технологии водопользования на рисовых системах для устойчивого рисоводства // Мелиорация и гидротехника. 2023. Т. 13, № 4. С. 114–130. DOI: 10.31774/2712-9357-2023-13-4-114-130.

3. Малышева Н.Н., Кизинек С.В. Экономические аспекты производства риса на мелиоративных системах Краснодарского края // Мелиорация и гидротехника. 2020. № 1 (37). С. 200–216. DOI: 10.31774/2222-1816-2020-1-200-216.

4. Балакай Г.Т., Масный П.С. Обоснование мероприятий по водосбережению на рисовых оросительных системах // Мелиорация и гидротехника. 2021. Т. 11, № 4. С. 1–16. DOI: 10.31774/2712-9357-2021-11-4-1-16.

5. Малышева Н.Н., Ковалева К.Ю., Хилько А.С. Анализ динамики объемов подаваемой воды на орошение риса // Заметки ученого. 2021. № 9–1. С. 252–259.

6. Кружилин И.П., Ганиев М.А., Родин К.А., Кузнецова Н.В. Менее водозатратная и экологически предпочтительная технология орошения риса периодическими поливами // Известия Нижневолжского агроуниверситетского комплекса: Наука и высшее профессиональное образование. 2019. № 2 (54). С. 49–55. DOI: 10.32786/2071-9485-2019-02-4.

7. Кружилин И.П., Новиков А.Е., Дубенок Н.Н. Обоснование водного режима почвы и регламента поливов аэробного риса // Вестник российской сельскохозяйственной науки. 2021. № 1. С. 62–66. DOI: 10.30850/

- vrsn/2021/1/62-66.
8. Бондаренко А.Н., Гусакова Н.Н., Жук Е.А. Влияние минерального питания на урожайность и качество зерна озимых зерновых культур // Аграрный научный журнал. 2020. № 2. С. 4–8. DOI: 10.28983/asj.y2020i2pp4-8.
  9. Кизинек С.В., Тараненко В.В., Белоусов В.С., Шарифуллин Р.С. Испытание сорговых культур в условиях рисового севооборота // Рисоводство. 2021. № 2 (51). С. 34–37. DOI: 10.33775/1684-2464-2021-51-2-34-37.
  10. Ибраева М.А., Сулейменова А.И., Сундет Т.Р. Накопление растительных остатков и их влияние на гумусное состояние почв рисово-люцернового севооборота // Почвоведение и агрохимия. 2022. № 3. С. 26–37. DOI: 10.51886/1999-740X\_2022\_3\_26.
  11. Белоусов И.Е. Изменение показателей эффективного плодородия почвы в рисовом севообороте // Рисоводство. 2021. № 3 (52). С. 47–52. DOI: 10.33775/1684-2464-2021-52-3-47-52.
  12. Гергель В.В. Урожайность и продуктивность парозанимающих культур в рисовом севообороте // Рисоводство. 2022. № 3 (56). С. 56–60. DOI: 10.33775/1684-2464-2022-56-3-56-60.
  13. Кравченко Р.В., Бардак Н.И., Коваль Д.Н. Роль предшественника в сортовой агротехнологии возделывания риса // Политематический сетевой электронный научный журнал Кубанского государственного аграрного университета. 2022. № 184. С. 348–363. DOI: 10.21515/1990-4665-184-031.
  14. Магомедов Н.Р., Казиметова Ф.М., Сулейманов Д.Ю. Урожайность новых сортов риса в зависимости от минерального питания в Терско-Сулакской подпровинции Дагестана // Проблемы развития АПК региона. 2022. № 2 (50). С. 70–76. DOI: 10.52671/20790996\_2022\_2\_70.
  15. Дедова Э.Б., Кониева Г.Н. Агроэкологическая оценка почв рисовых севооборотов Сарпинской низменности // Российская сельскохозяйственная наука. 2019. № 1. С. 34–39. DOI: 10.31857/S2500-26272019134-39.
  16. Неvezhina A.B. Обоснование возделывания риса по разным предшественникам при периодическом орошении // Орошаемое земледелие. 2021. № 4. С. 20–23. DOI: 10.35809/2618-8279-2021-4-2.
  1. Zelenskii P.G., Zelenskaya O.V. Evaluation of ecological and economic efficiency of resource and nature-saving rice cultivation technologies. *Risovodstvo = Rice Growing*, 2021, no. 4 (53), pp. 17–22. (In Russian). DOI: 10.33775/1684-2464-2021-53-4-17-22.
  2. Geras'kina T.V., Bandurin M.A., Prikhod'ko I.A. Improving water management technology in rice systems for sustainable rice production. *Melioratsiya i gidrotekhnika = Land Reclamation and Hydraulic Engineering*, 2023, vol. 13, no. 4, pp. 114–130. (In Russian). DOI: 10.31774/2712-9357-2023-13-4-114-130.
  3. Malysheva N.N., Kizinek S.V. Economic aspects of rice production on reclamation systems of the Krasnodar Territory. *Melioratsiya i gidrotekhnika = Land Reclamation and Hydraulic Engineering*, 2020, no. 1 (37), pp. 200–216. (In Russian). DOI: 10.31774/2222-1816-2020-1-200-216.
  4. Balakai G.T., Masnyi R.S. Water saving measures substantiation for rice irrigation systems. *Melioratsiya i gidrotekhnika = Land Reclamation and Hydraulic Engineering*, 2021, vol. 11, no. 4, pp. 1–16. (In Russian). DOI: 10.31774/2712-9357-2021-11-4-1-1 16.
  5. Malysheva N.N., Kovaleva K.Yu., Khil'ko A.S. Analysis of the dynamics of the volume of water supplied for irrigation of rice. *Zametki uchenogo = Notes of the scientist*, 2021, no. 9–1, pp. 252–259. (In Russian).
  6. Kruzhilin I.P., Ganiev M.A., Rodin K.A., Kuznetsova N.V. Less water-consuming and environmentally preferable technology of rice irrigation by periodic watering. *Izvestiya Nizhnevolzhskogo agrouniversitetskogo kompleksa: Nauka i vysshee professional'noe obrazovanie = Izvestia of the Lower Volga Agro-University Complex*, 2019, no. 2 (54), pp. 49–55. (In Russian). DOI: 10.32786/2071-9485-2019-02-4.
  7. Kruzhilin I.P., Novikov A.E., Dubenok N.N. Justification of water regime and irrigation regulations for aerobic rice. *Vestnik Rossiiskoi sel'skokhozyaistvennoi nauki = Vestnik of the Russian agricultural science*, 2021, no. 1, pp. 62–66. (In Russian). DOI: 10.30850/VRSN/2021/1/62-66.
  8. Bondarenko A.N., Gusakova N.N., Zhuk E.A. Influence of mineral nutrition on yield and grain quality of winter grain crops. *Agrarnyi nauchnyi zhurnal = Agrarian Scientific Journal*, 2020, no. 2, pp. 4–8. (In Russian). DOI: 10.28983/asj.y2020i2pp4-8.
  9. Kizinek S.V., Taranenko V.V., Belousov V.S., Sharifullin R.S. Testing of sorghum crops in

## REFERENCES

- conditions of rice crop rotation. *Risovodstvo = Rice Growing*, 2021, no. 2 (51), pp. 34–37. (In Russian). DOI: 10.33775/1684-2464-2021-51-2-34-37.
10. Ibraeva M.A., Suleimenova A.I., Sundet T.R. Accumulation of plant residues and their influence on the humus condition of soils of rice-lucerne crop rotation. *Pochvovedenie i agrokhimiya = Soil Science and Agrochemistry*, 2022, no. 3, pp. 26–37. (In Russian). DOI: 10.51886/1999-740x\_2022\_3\_26.
  11. Belousov I.E. Changing soil efficiency rates in rice crop rotation. *Risovodstvo = Rice Growing*, 2021, no. 3 (52), pp. 47–52. (In Russian). DOI: 10.33775/1684-2464-2021-52-3-47-52.
  12. Gergel V.V. Yield and productivity of fallow crops of rice crop rotation. *Risovodstvo = Rice Growing*, 2022, no. 3 (56), pp. 56–60. (In Russian). DOI: 10.33775/1684-2464-2022-56-3-56-60.
  13. Kravchenko R.V., Bardak N.I., Koval' D.N. The role of the precursor in variety agricultural technology of rice culture. *Politematicheskii setevoi elektronnyi nauchnyi zhurnal Kubanskogo gosudarstvennogo agrarnogo universiteta = Polythematic online scientific journal of Kuban State Agrarian University*, 2022, no. 184, pp. 348–363. (In Russian). DOI: 10.21515/1990-4665-184-031.
  14. Magomedov N.R., Kazimetova F.M., Suleimanov D.Yu. Yield of new rice varieties depending on the mineral nutrition in the Tersko-Sulak subprovincion of Dagestan. *Problemy razvitiya APK regiona = Problems of the development of the agricultural sector of the region*, 2022, no. 2 (50), pp. 70–76. (In Russian). DOI: 10.52671/20790996\_2022\_2\_70.
  15. Dedova E.B., Konieva G.N. Agroecological assessment of soils of rice crop rotations of the Sarpinsky lowland. *Rossiiskaya sel'skokozyaistvennaya nauka = Russian Agricultural Science*, 2019, no. 1, pp. 34–39. (In Russian). DOI: 10.31857/S2500-26272019134-39.
  16. Nevezhina A.B. Justification of rice cultivation by different predecessors with periodic irrigation. *Oroshaemoe zemledelie = Irrigated Agriculture*, 2021, no. 4, pp. 20–23. (In Russian). DOI: 10.35809/2618-8279-2021-4-2.

#### ИНФОРМАЦИЯ ОБ АВТОРАХ

**Родин К.А.**, кандидат сельскохозяйственных наук, ведущий научный сотрудник; e-mail: rodin.ka@yandex.ru, ORCID: 0000-0003-3808-2729

✉ **Неvezhina А.Б.**, кандидат сельскохозяйственных наук, старший научный сотрудник; **адрес для переписки:** Россия, 400002, Волгоград, ул. Тимирязева, 9; e-mail: aina.kanaeva@mail.ru, ORCID: 0000-0002-3219-348X

#### AUTHOR INFORMATION

**Konstantin A. Rodin**, Candidate of Science in Agriculture, Lead Researcher; e-mail: rodin.ka@yandex.ru, ORCID: 0000-0003-3808-2729

✉ **Ainagul B. Nevezhina**, Candidate of Science in Agriculture, Senior Researcher; **address:** 9, Timiryazeva St., Volgograd, 400002, Russia; e-mail: aina.kanaeva@mail.ru, ORCID: 0000-0002-3219-348X

Дата поступления статьи / Received by the editors 09.07.2024  
Дата принятия к публикации / Accepted for publication 27.08.2024  
Дата публикации / Published 20.11.2024

## Влияние гидротермических условий на содержание белка и незаменимых аминокислот в пшене проса посевного в лесостепи Самарской области

✉ Антимонова О.Н., Антимонов А.К.

*Поволжский научно-исследовательский институт селекции и семеноводства им. П.Н. Константинова – филиал Самарского федерального исследовательского центра Российской академии наук*

Самарская область, г. Кинель, Россия

✉ e-mail: antimonovaolga@list.ru

Представлены результаты исследований по формированию количественного и качественного состава белка в пшене проса посевного разных сортов в зависимости от метеоусловий в течение вегетационного периода и отдельных фаз вегетации. Исследования проведены в 2018–2020 гг. в Самарской области на трех образцах крупы проса посевного: Поволжское 80 (среднеранний), Крестьянка и Россиянка (среднеспелые). Выявлена корреляционная зависимость содержания белка и незаменимых аминокислот между суммой активных температур и количеством осадков. Метеорологические условия экспериментальных годов можно охарактеризовать как неблагоприятные, засушливые, с неравномерным распределением осадков (ГТК 0,52–0,54). Отмечена положительная сильная связь между суммой активных температур и содержанием белка ( $r = 0,74-0,98$ ,  $d = 60,8-96,0\%$ ) в фазу всходы – полная спелость в зависимости от сорта. Корреляционная связь количества осадков с содержанием белка показала сильную отрицательную связь на всех сортах ( $r = -0,70 \dots -0,99$ ,  $d = 49,0-96,0\%$ ). Повышенный температурный режим и дефицит осадков способствовали увеличению процентного содержания белка в пшене проса изучаемых сортов. Понижение температурного режима и увеличение осадков вызывают снижение накопления белка. Первой дефицитной лимитирующей аминокислотой, по которой оценивают биологическую ценность белка, является лизин с наивысшим показателем 20,75% у сорта Поволжское 80. На увеличение содержания лизина у всех изучаемых сортов значительное влияние оказывает температурный режим июля в фазе кущение – выметывание ( $r = 0,73-0,99$ ).

**Ключевые слова:** просо посевное, белок, биологическая ценность, аминокислоты, корреляция, погодные условия

## Influence of hydrothermal conditions on the content of protein and essential amino acids in common millet in the forest-steppe of the Samara region

✉ Antimonova O.N., Antimonov A.K.

*Povolzhsky Scientific Research Institute of Selection and Seed Growing named after P.N. Konstantinov – Branch of Samara Federal Research Scientific Center RAS*

Kinzel, Samara region, Russia

✉ e-mail: antimonovaolga@list.ru

The results of the studies on the formation of quantitative and qualitative composition of protein in millet of different varieties depending on meteorological conditions during the growing season and separate phases of vegetation are presented. The research was conducted in 2018-2020 in the Samara region on three samples of common millet groats: Povolzhskoe 80 (middle-early), Krestyanka and Rossiyanka (medium-maturing). Correlation dependence of protein and essential amino acids content between the sum of active temperatures and precipitation was revealed. Meteorological conditions of the experimental years can be characterized as unfavorable, arid, with uneven distribution of precipitation (HTC 0.52–0.54). A positive strong relationship was observed between the sum of active temperatures and protein content ( $r = 0.74-0.98$ ,  $d = 60.8-96.0\%$ ) in the phase of sprouting – full ripeness depending on the variety. The correlation of precipitation with protein content showed a strong negative relationship on all the varieties ( $r = -0.70 \dots -0.99$ ,  $d = 49.0-96.0\%$ ). Increased temperature regime and precipitation deficit contributed to the increase in the percentage of protein content in mil-

let groats of the studied varieties. Lower temperatures and increased precipitation cause a decrease in protein accumulation. The first deficient limiting amino acid, by which the biological value of protein is estimated, is lysine with the highest value of 20.75% in the variety Povolzhskoe 80. The increase in lysine content in all the studied varieties is significantly influenced by the temperature regime in July in the phase of tillering – ear formation ( $r = 0,73-0,99$ ).

**Keywords:** common millet, protein, biological value, amino acids, correlation, weather conditions

**Для цитирования:** Антимонова О.Н., Антимонов А.К. Влияние гидротермических условий на содержание белка и незаменимых аминокислот в пшене проса посевного в лесостепи Самарской области // Сибирский вестник сельскохозяйственной науки. 2024. Т. 54. № 10. С. 48–57. <https://doi.org/10.26898/0370-8799-2024-10-5>

**For citation:** Antimonova O.N., Antimonov A.K. Influence of hydrothermal conditions on the content of protein and essential amino acids in common millet in the forest-steppe of the Samara region. *Sibirskii vestnik sel'skokhozyaistvennoi nauki = Siberian Herald of Agricultural Science*, 2024, vol. 54, no. 10, pp. 48–57. <https://doi.org/10.26898/0370-8799-2024-10-5>

#### Конфликт интересов

Авторы заявляют об отсутствии конфликта интересов.

#### Conflict of interest

The authors declare no conflict of interest.

## INTRODUCTION

Common millet (*Panicum miliaceum*) is a heat-loving crop known for its high tolerance to elevated temperatures and lack of precipitation. However, despite its drought resistance and heat tolerance, the dependence of yield and nutritional value of the grain on hydrothermal conditions remains quite high, especially during certain periods of the growing season<sup>1</sup> [1, 2]. Millet is a valuable cereal, food, and fodder crop. Traditional food products and beverages made from millet are widely produced and consumed by people in Africa, India, China, Eastern Europe, and Eurasia. Millet is used to prepare porridges, flatbreads, and both non-alcoholic and alcoholic beverages [3, 4].

Protein content and amino acid composition are the primary qualitative characteristics of millet, providing critical reference values for food processing, market grading, and varietal selection. Therefore, it is important to establish a comprehensive grain quality evaluation framework based on protein content and amino acid composition, as influenced by different weather conditions [5, 6].

Amino acids are the end product of protein breakdown in the digestive tract. They play a crucial role in metabolism, and many of them serve as activators of enzymes and vitamins [7, 8].

The proteins of common millet are not considered high biological value proteins, but when combined with legumes, they create an easily digestible, complete protein rich in nutrients [9, 10].

An optimal balance of amino acids in the diet is essential for proper growth, development, and health in both humans and animals [11]. Therefore, a database on the amino acid composition of food products is highly necessary to facilitate the formulation of animal diets and the management of balanced food consumption for humans [12, 13].

The purpose of the study is to investigate the influence of hydrothermal conditions on the protein content and essential amino acids in common millet grain, depending on the hydrothermal conditions of the Samara region.

Objectives of the study are to:

- analyze weather conditions during the growing season of millet of each variety;
- reveal correlation dependence of protein and essential amino acids content between the sum of active temperatures and the amount of precipitation;
- identify adaptive varieties that form high levels of protein and essential amino acids (EAAs) during years with extreme weather conditions.

<sup>1</sup>Surkov A.Yu., Surkova I.V. Formation of millet yield and its elements depending on hydrothermal conditions // Bulletin of the Kursk State Agricultural Academy, 2018, N 5, pp. 18-23.

## MATERIAL AND METHODS

Scientific research was conducted from 2018 to 2020 in the Laboratory of Breeding and Seed Production of Cereal and Sorghum Crops at the Povolzhsky Scientific Research Institute of Selection and Seed Growing named after P.N. Konstantinov, Branch of Samara Federal Research Scientific Center RAS. The studies were carried out on samples of common millet grain of the varieties Povolzhskoe 80 (mid-early), Krestyanka, and Rossiyanka (mid-season).

Field experiments were conducted in accordance with the methodology<sup>2</sup>. The total plot area was 25 m<sup>2</sup>, the sampling area was 23 m<sup>2</sup>, with four replications. The forecrop was spring barley. The seeding rate was 3.0 million seeds per hectare. Agricultural practices followed the standard practices of the region.

The analysis of protein content in millet was carried out using the InfraLUM FT infrared analyzer. The composition of essential amino acids—lysine, valine, leucine and isoleucine (combined), methionine, threonine, phenylalanine, and tryptophan—was determined using capillary electrophoresis with the Kapel 105M system.

Meteorological data were obtained from the meteorological station of the Samara State Agrarian University (Samara region, Ust-Kinelsky settlement). Among the meteorological factors, the following were analyzed: the sum of active air temperatures by growth phases of the varieties and over the growing season of each studied variety; total amount of precipitation and the hydrothermal coefficient (HTC)<sup>3</sup> of G.T. Selyaninov over the growing season of each studied variety.

The hydrothermal coefficient was determined by the formula

$$HTC = \frac{\Sigma R}{0,1\Sigma t^0 > 10^0},$$

where  $\Sigma R$  – the sum of precipitation in millimeters for the period with air temperatures higher than 10 °C;  $\Sigma t$  – the sum of temperatures in degrees for the same time.

The biological value of protein in groats of millet was determined by the amino acid scoring method, where the amino acid scale of the World Health Organization and the United Nations Food Committee (FAO/WHO scale) is used as an ideal amino acid scale. Calculation of amino acid scoring was carried out by the formula

$$\begin{aligned} \text{Amino-acid score} &= \\ &= \frac{\text{mg AA in 1 g of the tested protein}}{\text{mg AA in 1 g of ideal protein}} \times 100\%. \end{aligned}$$

The results of the experiment were processed by statistical correlation analyses according to B.A. Dospekhov<sup>4</sup> using the Microsoft Exel computer program.

## RESULTS AND DISCUSSION

Meteorological conditions of the experimental years can be characterized as unfavorable, dry, with uneven distribution of precipitation (HTC 0.5–0.54). On average, during the growing season in the variety Povolzhskoe 80 HTC amounted to 0.54 units, Krestyanka –0.53, Rossiyanka –0.52 units. The coefficients of variation were high – 25.7; 26.7 and 23.6%, respectively, which indicates an uneven amount of precipitation input (see Table 1).

For the formation of full ripeness of grain (for 77 days) the sum of active temperatures for the early variety Povolzhskoe 80 required on average 1701.1 °C. For medium-ripening variety Krestyanka (80.3 days) and late-ripening variety Rossiyanka (83.3 days) slightly more – 1755.3 and 1795.9 °C respectively. The variation of the sum of active temperatures in the years of research among the varieties was low, within 2.2–2.9%. Depending on the lengthening of the vegetation period of the varieties of different

<sup>2</sup>Methodology of state variety testing of agricultural crops. Moscow: State Variety Testing Commission, 2019, 329 p.

<sup>3</sup>Selyaninov G.T. Methodology of agricultural characterization of climate / World agroclimatic reference book, Moscow, 1977, 220 p.

<sup>4</sup>Dospekhov B.A. Methodology of field experiment (with the basics of statistical processing of research results). Moscow: Agropromizdat, 1985, 351 p.

**Табл. 1.** Гидротермические показатели в разные фазы вегетации сортов проса и содержание белка в пшенице (среднее за 2018–2020 гг.), %

**Table.** Hydrothermal parameters in different vegetation phases of common millet varieties and protein content in millet (average for 2018–2020), %

Variety (A), options (conditions) (B)	Povolzhskoe 80	CV, %	Krestyanka	CV, %	Rossiyanka	CV, %
Protein, %	10,8 ± 0,4	5,6	10,7 ± 0,3	4,7	11,6 ± 0,3	4,4
Sum of active temperatures, °C	1701,1 ± 43,3	2,3	1755,3 ± 28,6	2,9	1795,9 ± 45,4	2,2
Sprouting - tillering	266,7 ± 51,1	19,2	266,7 ± 51,1	19,2	266,7 ± 51,1	19,2
Tillering – ear formation	495,3 ± 51,1	7,6	576,6 ± 27,2	4,7	622,8 ± 46,4	2,5
Ear formation – full maturity	939,0 ± 37,5	4,6	912,0 ± 16,0	1,8	906,3 ± 31,5	7,5
Amount of precipitation, mm	92,7±12,3	23,0	92,7 ± 12,3	23,0	93,6 ± 11,5	21,2
Vegetation period	77,0 ± 1,0	2,2	80,3 ± 1,7	3,6	83,3 ± 2,1	4,5
HTC	0,54	25,7	0,53	26,7	0,52	23,6

LSD<sub>A</sub> = 10,9 (unreliable)

LSD<sub>B,AB</sub> = 16,7 (reliable)

LSD<sub>total</sub> = 29,0 (reliable)

ripeness groups, the sums of active temperatures tended to increase on average over the years.

Protein content in groats of millet of different varieties during the years of research varied insignificantly (with its average content in the varieties Volga 80 10.8 ± 0.4% and Krestyanka 10.7 ± 0.3%), fluctuated within the range

of 10.2–11.4%, respectively. The coefficient of variation (CV) amounted to 5.6-4.7% (see the figure, Table 1).

In the late variety Rossiyanka with an average protein content of 11.6 ± 0.3% by years it varied from 11.0 to 11.9% with a low coefficient of variation of 4.4%. Such a low percentage of



Диаграмма содержания белка в зерне проса разных сортов за 2018–2020 гг., %  
Diagram of protein content in millet grain of different varieties for 2018-2020, %

CV shows the annually stable protein formation even against the background of uneven distribution of weather conditions during the growing season of millet varieties.

All varieties showed an increase in protein content in groats at the highest temperature regime in 2019 with reduced precipitation. This indicates that high temperature background as well as low precipitation favors high expression of quantitative indicators of protein in millet groats compared to more favorable weather conditions during the growing season (2018, 2020) (see the figure, Table 2).

The influence of meteorological factors on protein content in groats of millet of different varieties shows the correlation analysis displayed in Table 3.

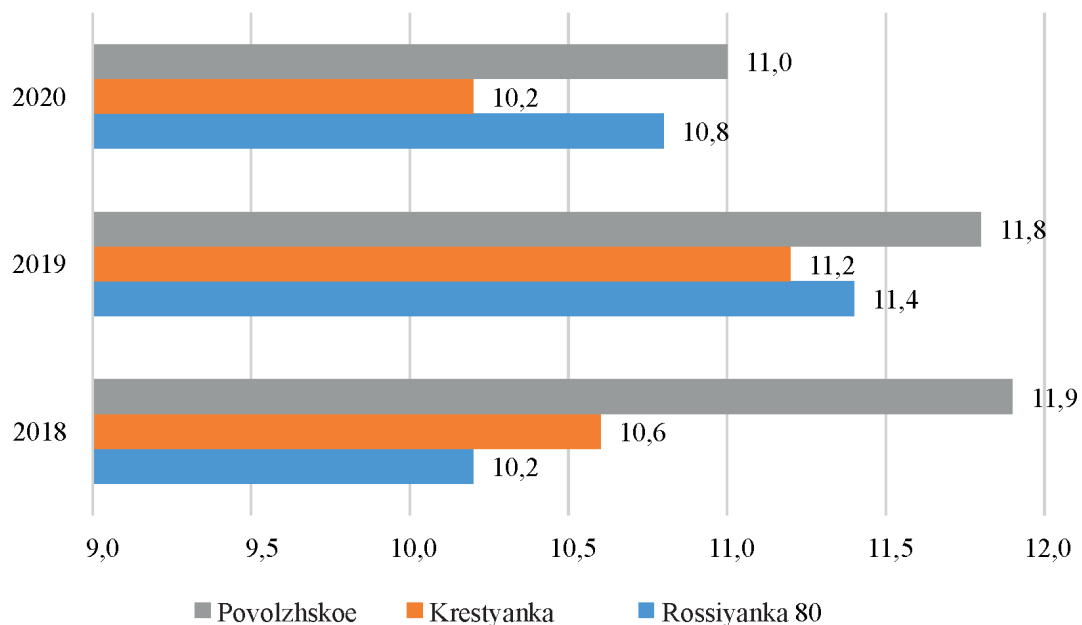
If during vegetation the studied varieties reacted differently to the sum of active temperatures in different phases of vegetation, then in general for the period of sprouting - full ripeness all varieties showed high reliable correlation with the coefficient of determination 54.8–

98.0%, attributable to the share of heat availability of plants. However, it should be taken into account that the quantitative level of protein in millet groats depends not only on meteorological factors, but also on many other factors, including varietal characteristics, agrotechnical, soil-climatic zones, etc.

Analysis of contrasting hydrothermal conditions during the main growth phases of common millet also revealed some features of the amino acid composition of millet grain protein in varieties with different maturation periods. During the growing season (sprouting to complete ripeness), the highest content of threonine, methionine, valine, leucine + isoleucine, and phenylalanine under elevated temperature conditions and precipitation deficit was observed in the middle-early variety Povolzhskoe 80, as confirmed by the correlation coefficients ( $r = 0.43–0.99$ ). Similar conditions during this period are required for high levels of lysine and phenylalanine in the variety Krestyanka ( $r = 0.65$  and  $0.86$ , respectively). In more favorable

**Табл. 2.** Содержание незаменимых аминокислот (НАК) в крупе проса посевного разных сортов (2018–2020 гг.), г/кг

**Table 2.** Content of essential amino acids (EAA) in millet groats of different varieties (2018–2020), g/kg

Year	Sum of active temperatures, °C	Amount of precipitation, mm	EAAs									CV, %
			Lysine	Threonine	Methionine	Valine	Leucine + Isoleucine	Phenylalanine	Tryptophane	Sum	Average	
<i>Povolzhskoe 80</i>												
2018	1676,4	97,6	1,3	2,1	2,2	3,6	12,3	3,6	0,6	25,7	26,1	9,93
2019	1779,9	69,3	1,2	2,3	3,7	4,3	12,2	4,2	0,9	28,8		
2020	1646,9	111,1	1,2	2,0	1,8	4,2	9,6	3,9	1,1	23,8		
<i>Krestyanka</i>												
2018	1754,9	97,6	1,2	2,3	2,1	3,6	12,0	3,5	1,1	25,8	22,6	13,8
2019	1814,7	69,3	1,1	1,5	2,0	3,4	9,9	3,5	0,9	22,3		
2020	1696,3	111,1	0,9	1,1	2,5	3,5	7,5	3,0	1,1	19,6		
<i>Rossiyanka</i>												
2018	1793,5	97,7	1,5	2,6	2,3	4,5	15,8	4,2	0,6	31,5	26,5	24,4
2019	1842,4	72,0	0,9	1,7	1,7	3,3	10,3	3,7	1,0	22,6		
2020	1751,7	111,1	1,2	2,4	3,2	4,0	9,9	3,5	1,1	25,3		

**Табл. 3.** Коэффициенты корреляции между суммой активных температур и содержанием белка в крупе сортов проса посевного по основным фазам развития

**Table. 3.** Indicators of correlation coefficients between the sum of active temperatures and the content of protein in the groats of millet varieties by the main phases of development

Indicator	Povolzhskoe 80		Krestyanka		Rossiyanka	
	<i>r</i>	<i>d</i>	<i>r</i>	<i>d</i>	<i>r</i>	<i>d</i>
<i>Sprouting - tillering</i>						
Protein	0,77	59,3	0,97	94,1	0,56	31,4
Lysine	-0,34	11,6	0,36	13,0	-0,77	59,3
Threonine	0,99	98,0	-0,02	0	-0,93	86,5
Methionine	0,99	98,0	-0,78	60,8	-0,89	79,2
Valine	0,46	21,2	-0,77	59,3	-0,82	67,2
Leucine + isoleucine	0,61	37,2	0,21	4,4	-0,28	7,8
Phenylalanine	0,77	59,3	0,64	41,0	-0,07	0
Tryptophane	-0,06	0	-0,98	96,0	0,16	2,6
<i>Tillering – ear formation</i>						
Protein	-0,80	64,0	-0,16	2,6	0,20	4,0
Lysine	0,99*	98,0	0,73	53,3	0,99*	98,0
Threonine	-0,06	0	0,93	86,5	0,92	84,6
Methionine	-0,19	3,6	-0,28	7,8	0,30	9,0
Valine	-0,97	94,1	0,89	79,2	0,98	96,0
Leucine + isoleucine	0,63	39,7	0,81	65,6	0,88	77,4
Phenylalanine	-0,80	64,0	0,46	21,2	0,76	57,8
Tryptophane	-0,96	92,2	0,54	29,2	-0,82	67,2
<i>Ear formation – full maturity</i>						
Protein	0,98*	96,0	0,85*	72,3	-0,08	0
Lysine	-0,95	90,3	0,03	0	-0,99	98,0
Threonine	0,49	24,0	-0,34	11,6	-0,96	92,2
Methionine	0,60	36,0	-0,53	28,1	-0,42	17,6
Valine	0,98	96,0	-0,93	86,5	-0,99	98,0
Leucine + isoleucine	-0,23	5,29	-0,12	14,4	-0,82	67,2
Phenylalanine	0,98	96,0	0,36	13,0	-0,68	46,2
Tryptophane	0,75	56,3	-0,99	98,0	0,74	54,8
<i>Sprouting - full maturity</i>						
Protein	0,74	54,8	0,99	98,0	0,78	60,8
Lysine	-0,31	9,6	0,65	42,3	-0,54	29,2
Threonine	0,99*	98,0	0,32	10,2	-0,77	59,3
Methionine	0,99*	98,0	-0,94	88,4	-0,99	98,0
Valine	0,43	18,5	-0,51	26,0	-0,62	38,4
Leucine + isoleucine	0,65	42,3	0,53	28,1	0,02	0
Phenylalanine	0,74	54,8	0,86*	74,0	0,23	5,3
Tryptophane	-0,10	1,0	-0,87	75,7	-0,14	2,0
Protein	-0,70	49,0	-0,99*	98,0	-0,70	49,0
Lysine	0,20	4,0	-0,49	24,1	0,65	42,3
Threonine	-0,99*	98,0	-0,12	14,4	0,85	72,3
Methionine	-0,99	98,0	0,86	74,0	0,96	92,2
Valine	-0,33	10,9	0,66	43,6	0,71	50,4
Leucine + isoleucine	-0,73	53,3	-0,35	12,3	0,12	1,4
Phenylalanine	-0,66	43,6	-0,74	54,8	-0,10	0
Tryptophane	0,21	44,1	0,95	90,3	0,01	0

\*Reliable at  $p \leq 0,05$ ..

weather years, these indicators decrease. A weak to strong inverse correlation and a weak direct correlation during the emergence to full maturity period were observed in the medium-maturing variety Rossiyanka for all essential amino acids. Significant influence on the accumulation of all essential amino acids (EAAs) was exerted by the temperature regime only during the tillering to heading phase ( $r = 0.30-0.99$ ) (see Tables 2–4).

It was experimentally revealed that the increase in lysine content in all studied varieties is significantly influenced by the temperature regime of July in the phase of tillering – sprouting ( $r = 0.73-0.99$ ), at the rest of the time it needs more precipitation.

The content of essential amino acids in protein is used to calculate the amino acid score, which characterizes the biological value of protein [14]. In the reference protein it is equal to

100%. If the amino acid score exceeds 100%, the amino acid is in excess, if it is less than 100%, it is in deficiency [15]. The amino acid with the lowest score is considered to be the first limiting amino acid, which is used to determine the biological value of protein. In our studies, all amino acids are limiting, except phenylalanine in the variety Povolzhskoe 80, the score of which exceeds the reference values by 3.37%. The first deficient limiting amino acid is lysine, which varies in the range of 18,31 – 20,75% (see Table 5).

The medium-early variety Povolzhskoe 80 showed a tendency to accumulate a greater amount of the limiting amino acid lysine (20.75%), which is probably due to its early maturity, adaptability to increased temperature regime with acute precipitation deficit during the growing season. However, it should be noted

**Табл. 4.** Коэффициенты корреляции между количеством осадков и содержанием белка и НАК в крупе сортов проса посевного за период всходы – полная спелость

**Table 4.** Indicators of correlation coefficients between the amount of precipitation and the content of protein and EAA in the groats of millet varieties for the period "germination – full ripeness"

Variety / growth phase	Povolzhskoe 80		Krestyanka		Rossiyanka	
	<i>r</i>	<i>d</i>	<i>r</i>	<i>d</i>	<i>r</i>	<i>d</i>
Protein	-0,70	49,0	-0,99*	98,0	-0,70	49,0
Lysine	0,20	4,0	-0,49	24,1	0,65	42,3
Threonine	-0,99*	98,0	-0,12	14,4	0,85	72,3
Methionine	-0,99	98,0	0,86	74,0	0,96	92,2
Valine	-0,33	10,9	0,66	43,6	0,71	50,4
Leucine + isoleucine	-0,73	53,3	-0,35	12,3	0,12	1,4
Phenylalanine	-0,66	43,6	-0,74	54,8	-0,10	0
Tryptophane	0,21	44,1	0,95	90,3	0,01	0

**Табл. 5.** Биологическая ценность белка крупы проса по аминокислотному score, %

**Table 5.** Biological value of millet groats protein by amino acid score, %

Variety	Lysine	Threonine	Methionine	Valine	Leucine + isoleucine	Phenylalanine	Tryptophane
Povolzhskoe 80	20,75*	49,40	99,33	74,76	95,88	103,37	80,70
Krestyanka	18,31*	38,33	86,25	65,86	83,81	89,51	96,90
Rossiyanka	18,87*	51,90	86,50	67,98	94,36	93,91	71,70

\* The first limiting amino acid.

that the correlation analysis of the influence of hydrothermal conditions on the content of protein and essential amino acids in groats of millet does not provide a complete explanation of cause-and-effect relationships, but only provides an understanding of their strength and form of interaction, and makes it possible to analyze the results of research.

## CONCLUSIONS

1. Meteorological conditions of the experimental years can be characterized as unfavorable, arid, with uneven distribution of precipitation (HTC 0.52–0.54).

2. It was revealed that high temperature background and low precipitation contribute to the increase of protein in millet groats of all studied varieties during the growing season. A direct strong relationship between the sum of active temperatures and protein content ( $r = 0.74-0.98$ ,  $d = 60.8-96.0\%$ ) in the phase of sprouting - full ripeness depending on the variety has been established.

3. Decrease in temperature regime and increase in precipitation contribute to the decrease in protein accumulation. Correlation of precipitation with protein content showed a strong negative relationship in all varieties ( $r = -0.70 \dots -0.99$ ,  $d = 49.0-96.0\%$ ).

4. Strong and average influence of air temperature on more intensive formation of EAA in separate phases of vegetation of common millet varieties was revealed. In the period of sprouting – tillering in the variety Volga 80 – threonine and methionine ( $r = 0.99$ ), leucine + isoleucine ( $r = 0.61$ ), phenylalanine ( $r = 0.77$ ); in the variety Krestyanka – phenylalanine ( $r = 0.64$ ). In the period of tillering – sprouting in the variety Volga 80 – lysine ( $r = 0.99$ ), leucine + isoleucine ( $r = 0.63$ ); in the variety Krestyanka – lysine ( $r = 0.73$ ), threonine ( $r = 0.93$ ), valine ( $r = 0.89$ ), tryptophan ( $r = 0.54$ ); in the variety Rossiyan-ka – lysine ( $r = 0.99$ ), threonine ( $r = 0.92$ ), valine ( $r = 0.98$ ), leucine + isoleucine ( $r = 0.88$ ), phenylalanine ( $r = 0.76$ ). In the period of ear formation – full ripeness in the variety Volga 80 – methionine ( $r = 0.60$ ), valine ( $r = 0.98$ ); in the

variety Krestyanka – lysine ( $r = 0.73$ ), threonine ( $r = 0.93$ ), valine and phenylalanine ( $r = 0.98$ ), tryptophan ( $r = 0.75$ ); in the variety Rossiyan-ka – tryptophan ( $r = 0.74$ ).

5. The first deficient limiting amino acid, by which the biological value of protein is estimated, is lysine with the highest index (20.75%) in the variety Povolzhskoe 80. The increase in lysine content in all the studied varieties is significantly influenced by the temperature regime in July in the phase of tillering – sprouting ( $r = 0.73-0.99$ ).

## СПИСОК ЛИТЕРАТУРЫ

1. Антимонова О.Н., Сыркина Л.Ф. Формирование урожайности сортов проса посевного в зависимости от гидротермических условий // Вестник КрасГАУ. 2020. № 10. С. 74–82. DOI: 10.36718/1819-4036-2020-10-74-82.
2. Камалеев Р.Д. Влияние факторов погоды на колебание продуктивности проса посевного // Вестник Ульяновской государственной сельскохозяйственной академии. 2023. № 3 (63). С. 58–62. DOI: 10.18286/1816-4501-2023-3-58-62.
3. Kasule F., Ojulong H.F., Wandulu J.A., Kakeo R., Adikini S. Pearl millet: A marginalized solution to climate change adaptation, nutrition and food security challenges in Uganda // Journal of Plant Breeding and Crop Science. 2024. Vol. 16 (3). P. 46–62. DOI: 10.5897/JP-BCS2023.1029.
4. Баюров Л.И., Дмитриенко С.Н. Просо и его значение в питании людей и животных // Политематический сетевой электронный журнал Кубанского государственного аграрного университета. 2023. № 191. С. 349–368. DOI: 10.21515/1990-4665-191-039.
5. Hou S., Men Y., Wei M., Zhang Y., Li H., Sun Z., Han Y. Total Protein Content, Amino Acid Composition and Eating-Quality Evaluation of Foxtail Millet (*Setaria italica* (L.) P. Beauv) // Foods. 2023. Vol. 12 (31). DOI: 10.3390/foods12010031.
6. Зотиков В.И., Сидоренко В.С., Грядунова Н.В., Вилюнов С.Д. Потенциал проса в новых рыночных условиях // Зернобобовые и крупяные культуры. 2023. № 1 (45). С. 5–11. DOI: 10.24412/2309-348X-2023-1-5-11.
7. Кабылда А.И., Мыктабаева А.С., Серикбай Г.С., Кажыбекова А.С., Сантыгай Ф.С.,

- Муслимов Н.Ж. Изучение аминокислотного состава различных видов безглютеновой муки // Известия Нижневолжского агроуниверситетского комплекса. 2022. № 3 (67). С. 153–161. DOI: 10.32786/2071-9485-2022-03-18.
8. *Shilpa Sood S., Mohiuddin F., Mohiuddin Bhat F.* Evaluation of Chemical Composition Protein Quality and Amino Acid Scoring WHO/FAO Standards of Functional Cereals Oat Pearl Millet Sorghum and Finger Millet // *International Journal of Pharmacognosy & Chinese Medicine*. 2023. Vol. 7 (2). P. 000241. DOI: 10.23880/ipcm-16000241.
  9. *Anitha S., Govindaraj M., Kane-Potaka J.* Balanced amino acid and higher micronutrients in millets complements legumes for improved human dietary nutrition // *Cereal Chem*. 2019. Vol. 97. P. 74–84. DOI: 10.1002/cche.10227.
  10. *Чугунова О.В., Пономарев А.С., Пастушкова А.В.* Направления использования зернового сырья в производстве продуктов общественного питания // *Технологии пищевой и перерабатывающей промышленности АПК – продукты здорового питания*. 2022. № 4. С. 45–52. DOI: 10.24412/2311-6447-2022-4-45-52.
  11. *Li P., He W., Wu G.* Composition of Amino Acids in Foodstuffs for Humans and Animals // *Amino Acids in Nutrition and Health. Advances in Experimental Medicine and Biology*. 2021. Vol. 1332. P. 189–210. DOI: 10.1007/978-3-030-74180-8\_11.
  12. *Wiedemair V., Scholl-Bürgi S., Karall D., Huck C.W.* Amino Acid Profiles and Compositions of Different Cultivars of *Panicum miliaceum* L. // *Chromatographia*. 2020. Vol. 83. P. 829–837. DOI: 10.1007/s10337-020-03899-8.
  13. *Abah C.R., Ishiwu C.N., Obiegbuna J.E., Olathejo A.A.* Nutritional Composition, Functional Properties and Food Applications of Millet Grains // *Asian Food Science Journal*. 2020. N 14 (2). P. 9–19. DOI: 10.9734/afsj/2020/v14i230124.
  14. *Sachdeva N., Goomer S., Singh L.R., Pathak V.M., Chowhan R.K.* Current status of millet seed proteins and its applications: A comprehensive review // *Applied Food Research*. 2023. Vol. 3 (1). P. 00288. DOI: 10.1016/j.afres.2023.100288.
  15. *Антимонов А.К., Антимонова О.Н., Малахова О.А., Никонорова Ю.Ю.* Сравнительная эффективность различных методов определения биологической ценности крупы проса посевного // *Земледелие*. 2023. № 4. С. 40–43. DOI: 10.24412/0044-3913-2023-4-40-43.
- ## REFERENCES
1. Antimonova O.N., Syrkina L.F. The formation of crop yield of millet varieties depending on hydrothermal conditions. *Vestnik KrasGAU = Bulletin of KrasSAU*, 2020, no. 10, pp. 74–82. (In Russian). DOI: 10.36718/1819-4036-2020-10-74-82.
  2. Kamaleev R.D. Influence of weather factors on fluctuations in the productivity of common millet. *Vestnik Ul'yanovskoy gosudarstvennoy sel'skokhozyaystvennoy akademii = Vestnik of Ulyanovsk State Agricultural Academy*, 2023, no. 3 (63), pp. 58–62. (In Russian). DOI: 10.18286/1816-4501-2023-3-58-62.
  3. Kasule F., Ojulung H.F., Wandulu J.A., Kakeo R., Adikini S. Pearl millet: A marginalized solution to climate change adaptation, nutrition and food security challenges in Uganda. *Journal of Plant Breeding and Crop Science*, 2024, vol. 16 (3), pp. 46–62. DOI: 10.5897/JPBCS2023.1029.
  4. Bayurov L.I., Dmitrienko S.N. Millet and its importance in the nutrition of people and animals. *Politicheskii setevoy elektronnyy zhurnal Kubanskogo gosudarstvennogo agrarnogo universiteta = Polythematic online scientific journal of Kuban State Agrarian University*, 2023, no. 191, pp. 349–368. (In Russian). DOI: 10.21515/1990-4665-191-039.
  5. Hou S., Men Y., Wei M.; Zhang Y., Li H., Sun Z., Han Y. Total Protein Content, Amino Acid Composition and Eating-Quality Evaluation of Foxtail Millet. (*Setaria italica* (L.) Foods, 2023, vol. 12 (31). DOI: 10.3390/foods12010031.
  6. Zotikov V.I., Sidorenko V.S., Gryadunova N.V., Vilyunov S.D. Millet potential in new market conditions. *Zernobobovyye i krupyanyye kul'tury = Legumes and Groat Crops*, 2023, no. 1 (45), pp. 5–11. (In Russian). DOI: 10.24412/2309-348X-2023-1-5-11.
  7. Kabylda A.I., Myktabaeva A.S., Serikbay G.S., Kazhybekova A.S., Santygai F.S., Muslimov N.Zh. Studying the amino acid composition of various types of gluten-free flour. *Izvestiya Nizhnevolzhskogo agrouniversitetskogo kompleksa = News of the Lower Volga Agro-University Complex*, 2022, no. 3 (67), pp. 153–161.

- (In Russian). DOI: 10.32786/2071-9485-2022-03-18.
8. Shilpa Sood S., Mohiuddin F. Mohiuddin Bhat F. Evaluation of Chemical Composition Protein Quality and Amino Acid Scoring WHO/FAO Standards of Functional Cereals Oat Pearl Millet Sorghum and Finger Millet. *International Journal of Pharmacognosy & Chinese Medicine*, 2023, vol. 7 (2), p. 000241. DOI: 10.23880/ipcm-16000241.
  9. Anitha S., Govindaraj M., Kane-Potaka J. Balanced amino acid and higher micronutrients in millets complements legumes for improved human dietary nutrition. *Cereal Chem*, 2019, vol. 97, pp. 74–84. DOI: 10.1002/cche.10227.
  10. Chugunova O.V., Ponomarev A.S., Pastushkova A.V. Directions of using grain raw materials in the production of public catering products. *Tekhnologii pishchevoy i pererabatyvayushchey promyshlennosti APK – produkty zdorovogo pitaniya = Technology of food and processing industry of agro-industrial complex – healthy food*, 2022, no. 4, pp. 45–52. (In Russian). DOI: 10.24412/2311-6447-2022-4-45-52.
  11. Li P., He W., Wu G. Composition of Amino Acids in Foodstuffs for Humans and Animals. *Amino Acids in Nutrition and Health. Advances in Experimental Medicine and Biology*, 2021, vol. 1332, pp. 189–210. DOI: 10.1007/978-3-030-74180-8\_11.
  12. Wiedemair V., Scholl-Bürgi S., Karall D., Huck C.W. Amino Acid Profiles and Compositions of Different Cultivars of Panicum miliaceum L. *Chromatographia*, 2020, vol. 83, pp. 829–837. DOI: 10.1007/s10337-020-03899-8.
  13. Abah C.R., Ishiwu C.N., Obiegbuna J.E., Oladejo A.A. Nutritional Composition, Functional Properties and Food Applications of Millet Grains. *Asian Food Science Journal*, 2020, no. 14 (2), pp. 9–19. DOI: 10.9734/afsj/2020/v14i230124.
  14. Sachdeva N., Goomer S., Singh L.R., Pat-hak V.M., Chowhan R.K. Current status of millet seed proteins and its applications: A comprehensive review *Applied Food Research*, 2023, vol. 3 (1), p. 00288. DOI:10.1016/j.afres.2023.100288.
  15. Antimonov A.K., Antimonova O.N., Malakhova O.A., Nikonorova Yu.Yu. Comparative efficiency of various methods for determining the biological value of millet groats. *Zemledeliye = Zemledelie*, 2023, no. 4, pp. 40–43. (In Russian). DOI: 10.24412/0044-3913-2023-4-40-43.

## ИНФОРМАЦИЯ ОБ АВТОРАХ

✉ **Антимонова О.Н.**, кандидат сельскохозяйственных наук, старший научный сотрудник; **адрес для переписки:** Россия, 446442, Самарская область, п.г.т. Усть-Кинельский, ул. Шоссейная, 76; e-mail: antimonovaolga@list.ru

**Антимонов А.К.**, кандидат сельскохозяйственных наук, старший научный сотрудник

## AUTHOR INFORMATION

✉ **Olga N. Antimonova**, Candidate of Science in Agriculture, Senior Researcher; **address:** 76, Shosseinaya St., Ust-Kinelsky, Samara Region, 446442, Russia; e-mail: antimonovaolga@list.ru

**Alexander K. Antimonov**, Candidate of Science in Agriculture, Senior Researcher

Дата поступления статьи / Received by the editors 31.07.2024  
Дата принятия к публикации / Accepted for publication 10.09.2024  
Дата публикации / Published 20.11.2024

## Изучение влияния органоминерального удобрения на устойчивость яблони к весенним заморозкам

✉ Ожерельева З.Е., Прудников П.С., Ступина А.Ю., Болгова А.О.

*Всероссийский научно-исследовательский институт селекции плодовых культур*

Орловская область, д. Жилина, Россия

✉ e-mail: ozherelieva@orel.vniispk.ru

В статье представлены результаты испытания нового препарата – природный растительный комплекс (ПРК) «Белый Жемчуг Универсальный Антифриз» (БЖУ Антифриз). Цель исследований – изучить влияние органоминерального удобрения на физиолого-биохимические показатели устойчивости яблони к весенним заморозкам. Объектом исследований служат яблони сорта Синап орловский из биоресурсной коллекции Всероссийского научно-исследовательского института селекции плодовых культур. Опыт заложен в трех вариантах: 1 – контроль (без обработки); 2 – некорневая обработка 1%-м раствором ПРК «БЖУ Антифриз»; 3 – некорневая обработка 3%-м раствором ПРК «БЖУ Антифриз». В каждом варианте три повторности, по пять учетных деревьев. В результате двухлетних исследований выявили, что трехкратная обработка 1%-м и 3%-м растворами препарата ПРК «БЖУ Антифриз» повысила в плодовых почках уровень связанной воды на 9,8 и 3,8% на фоне увеличения сахарозы на 32,3% по сравнению с контролем, что, предположительно, будет предохранять растительные клетки от замерзания в период весенних заморозков. При этом показано, что обработка препаратом ПРК «БЖУ Антифриз», вероятно, способствовала ускорению биосинтеза и транспорта пролина в распускающиеся плодовые почки. После трехкратной обработки 1%-м и 3%-м растворами препарата уровень пролина уменьшился в 8,0 и 9,2 раза соответственно, в контроле – в 7,8 раза. Кроме того, отмечено положительное влияние препарата ПРК «БЖУ Антифриз» на устойчивость цветков и бутонов яблони как в лабораторных, так и в полевых условиях. Таким образом, применение препарата ПРК «БЖУ Антифриз» позволяет повысить устойчивость растений к низкотемпературному стрессу в весенний период за счет оптимизации водного режима и улучшения углеводно-белкового обмена.

**Ключевые слова:** яблоня, Синап орловский, некорневая обработка, ПРК «БЖУ Антифриз», устойчивость к весенним заморозкам

## Study of the effect of organomineral fertilizer on the resistance of apple trees to spring frosts

✉ Ozherelieva Z.E., Prudnikov P.S., Stupina A.Yu., Bolgova A.O.

*Russian Research Institute of Fruit Crop Breeding*

Zhilina village, Orel region, Russia

✉ e-mail: ozherelieva@orel.vniispk.ru

The article presents the results of a new preparation test – natural plant complex (NPC) "White Pearl Universal Antifreeze" (WPU Antifreeze). The purpose of the research was to study the effect of organomineral fertilizer on physiological and biochemical indicators of apple tree resistance to spring frosts. The object of research is apple trees of the Sinap Orlovsky variety from the bioresource collection of the Russian Research Institute of Fruit Crop Breeding. The experiment was laid in three variants: 1 – control (no treatment); 2 – foliar treatment with 1% solution of the NPC "WPU Antifreeze"; 3 – foliar treatment with 3% solution of the NPC "WPU Antifreeze". There are three replications, with five record trees in each variant. Two-year studies revealed that three-fold treatment with 1 and 3% solutions of the NPC "WPU Antifreeze" preparation increased the level of bound water in the fruit buds by 9.8 and 3.8% against the background of sucrose increase by 32.3% compared to the control, which presumably protects plant cells from freezing during spring frosts. At the same time, it is shown that treatment with the NPC "WPU Antifreeze" preparation probably promoted acceleration of proline biosynthesis and transport into the budding fruit buds. After threefold treatment with 1 and 3% solutions of the drug, the level of proline decreased 8.0 and 9.2 times, respectively, in the control

by 7.8 times. In addition, the positive effect of the preparation NPC "WPU Antifreeze" on the stability of flowers and buds of apple trees both in laboratory and field conditions was noted. Thus, the application of the preparation NPC "WPU Antifreeze" allows increasing plant resistance to low-temperature stress in spring due to optimization of the water regime and improvement of carbohydrate-protein metabolism.

**Keywords:** apple, 'Sinap Orlovsky', foliar treatment, NPC "WPU Antifreeze", resistance to spring frosts

**Для цитирования:** Ожерельева З.Е., Прудников П.С., Ступина А.Ю., Болгова А.О. Изучение влияния органоминерального удобрения на устойчивость яблони к весенним заморозкам // Сибирский вестник сельскохозяйственной науки. 2024. Т. 54. № 10. С. 58–68. <https://doi.org/10.26898/0370-8799-2024-10-6>

**For citation:** Ozherelieva Z.E., Prudnikov P.S., Stupina A.Yu., Bolgova A.O. Study of the effect of organomineral fertilizer on the resistance of apple trees to spring frosts. *Sibirskii vestnik sel'skokhozyaistvennoi nauki = Siberian Herald of Agricultural Science*, 2024, vol. 54, no. 10, pp. 58–68. <https://doi.org/10.26898/0370-8799-2024-10-6>

#### Конфликт интересов

Авторы заявляют об отсутствии конфликта интересов.

#### Conflict of interest

The authors declare no conflict of interest.

#### Благодарность

Исследование выполнено за счет гранта Российского научного фонда № 24-26-00041 (<https://rscf.ru/project/24-26-00041/>).

#### Acknowledgements

The study was funded by the Russian Science Foundation grant No. 24-26-00041 (<https://rscf.ru/project/24-26-00041/>).

## INTRODUCTION

One of the reasons for the decline in the yield of fruit crops, particularly apple trees, is the damage to flowers and buds caused by spring frosts [1–3]. In the central fruit-growing zone of Russia, there is a trend of worsening weather conditions during the flowering period of orchard crops. In the Oryol region, during the flowering period of apple trees, low positive temperatures and morning frosts are observed almost every year. For example, in May 1999, a frost of  $-3\text{ }^{\circ}\text{C}$  was recorded; in 2000 and 2017, the air temperature dropped to  $-2\text{ }^{\circ}\text{C}$ , which severely damaged the flowers of most apple varieties.

One of the most promising methods for increasing the resistance of agricultural plants to adverse environmental factors is the use of preparations of various origins [4–7]. These include organic and inorganic compounds that, in small doses, stimulate physiological and biochemical processes, thereby altering the metabolism in plants by improving the availability and assimilation of nutrients [8–14]. A priority in this regard is the use of adaptogenic preparations, whose effects are associated not only with increased yield but also with enhanced plant re-

sistance to abiotic factors. Therefore, there is a need for research aimed at improving the resistance of apple trees to spring frosts through the use of a new adaptogenic preparation, "White Pearl Universal Antifreeze".

The purpose of the research was to study the effect of organomineral fertilizer "White Pearl Universal Antifreeze" on physiological and biochemical indicators of apple tree resistance to spring frosts.

## MATERIAL AND METHODS

In 2023 and 2024 tests of natural plant complex (NPC) "White Pearl Universal Antifreeze" (WPU Antifreeze) (OOO "Group of Companies AgroPlus", Russia) were conducted.

This preparation is a suspension of a group of minerals of natural origin with the addition of a concentrate of extracts of spruce, pine and Siberian fir needles. The complex includes: mineral elements ( $\text{SiO}_2$  – 5,6%,  $\text{N}_{\text{total}}$  – 2,0–6,0,  $\text{K}_2\text{O}$  – 1,0,  $\text{CaO}$  – 0,5,  $\text{MgO}$  – 0,7,  $\text{B}$  – 0,013,  $\text{Zn}$  – 0,015,  $\text{Mo}$  – 0,02,  $\text{Al}_2\text{O}_3$  – 0,16%), vitamins A (carotene, lutein), D (phytosterins), E, K,  $\text{B}_1$ ,  $\text{B}_2$ ,  $\text{B}_6$ , PP, H, essential oils, chlorophyll, flavonoids, sugars, proteins, amino acids.

The experiment was laid in three variants on a plot with dark gray forest soils. The object of study – apple trees of Sinap Orlovsky<sup>1</sup> variety. Planting year 2013, planting scheme 6 × 3 m. In each variant there were three replications, in each replication there were five survey trees. The agrotechnics was the generally accepted one for apple trees in the middle zone of horticulture.

The experiment options were:

1 – control (without treatment);

2 – foliar treatment with 1% solution of NPC “WPU Antifreeze”;

3 – foliar treatment with 3% solution of NPC “WPU Antifreeze”.

In the spring period, plants were treated three times foliarly with 1% and 3% solutions of NPC “WPU Antifreeze” in the phenophases “dormant bud - silver cone”, “Mouse’s Eye” and “closed inflorescence”.

To determine the fractional composition of water, sucrose content, and proline content in the bark of annual shoots and in fruit buds, samples were taken 5 days after each foliar treatment with the preparation. The fractional composition of water was determined using the Okuntsov–Marinchik method. The amount of bound water was calculated based on the difference between the total water content and the water that passed into the solution. Sucrose content<sup>2</sup> was determined using resorcinol reagent at a wavelength of 520 nm. The value was calculated using a calibration curve constructed for pure sucrose on a spectrophotometer (BioRad SmartSpec Plus, USA). Proline content<sup>3</sup> was determined by the reaction with ninhydrin. The amount of the amino acid was calculated using a calibration curve constructed for pure proline at a wavelength of 520 nm on a spectrophotometer.

After three foliar treatments with the experimental preparation, branches with inflorescences were taken for artificial freezing in triplicate. Each replicate included 100 flowers and buds.

Spring frosts (–3.0 and –4.0 °C) were simulated in a climate chamber PSL-2KPH (Espec, Japan). The freezing exposure lasted 3 hours, with a cooling rate of 1 °C per hour.

Experimental data were processed using analysis of variance (ANOVA) with the MS Excel software package, applying Fisher's criterion (*F*). The critical significance level was set at 5%. Arithmetic mean values (*M*) and the standard error of the mean were calculated ( $\pm$  *SEM*).

## RESULTS AND DISCUSSION

Foliar treatment with 1% and 3% solutions of NPC “WPU Antifreeze” in early spring 2023 increased by 2.3 and 2.1%, respectively, the level of water content of the tissues of annual shoots relative to the control. It is important to note that the fertilizer contributed to the increase in the free water fraction in shoots by 2.3% (1% solution) and 1.7% (3% solution), although statistically the differences between the variants were not confirmed (see fig. 1, *a*).

A similar picture was observed in 2024 (see fig. 1, *b*): the level of water content of the tissues of annual shoots in the same phenophase in the trees treated with 1% and 3% solutions of BZHU Antifreeze was higher by 5.7 and 5.0%, respectively, compared to the control. In both variants of the experiment, a 2.7-2.8-fold increase in the proportion of free water and a 1.2-fold decrease in bound water were recorded (see fig. 1, *b*). Presumably, the adaptogenic preparation NPC “WPU Antifreeze” contributed to the optimization of water regime of plants and, as a consequence, to the increase in the intensity of metabolic processes. This conclusion is confirmed by the results of biochemical studies.

With the increase in the intensity of metabolic processes, the treatment with 1% and 3% solutions of the preparation carried out at the end of April 2023 contributed to the fact that part of bound water was transferred to a more

<sup>1</sup><https://vniispk.ru/varieties/sinap-orlovskii>

<sup>2</sup>Turkina M.V., Sokolova S.V. Study of membrane transport of sucrose in plant tissue // Plant Physiology, 1972, vol. 19, N 5, pp. 912–919.

<sup>3</sup>Bates L.S., Waldren R.P., Teare I.D. Rapid determination of free proline for water-stress studies // Plant and Soil, 1973, vol. 39, pp. 205–207.

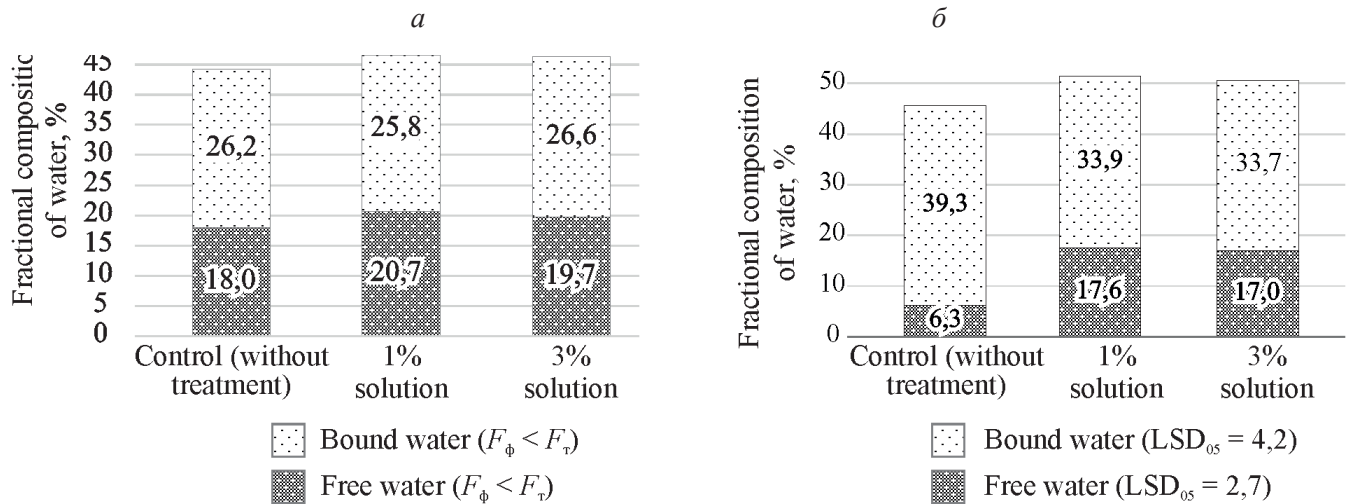

**Рис. 1.** Фракционный состав воды в тканях однолетних побегов в фенофазу «спящая почка – серебряный конус»: а – 2023 г.; б – 2024 г.

**Fig. 1.** Fractional composition of water in the tissues of annual shoots in the phenophase "dormant bud – silver cone": а – 2023; б – 2024

mobile form. In particular, in the treated trees, the amount of free water in the tissues of annual shoots increased by 4.7% compared to the control ( $LSD_{05} = 5.9$ ), and the level of bound water in fruit buds increased by 12.6 and 7.3%, respectively, compared to the control ( $LSD_{05} = 5.4$ ) (see fig. 2, a).

In 2024, the free water content did not change significantly after treatment with 1% and 3%

solutions of the preparation. The share of bound water in the tissues of annual shoots of the treated trees was higher by 4.7% (1% solution) and 6.8% (3% solution) relative to the control, but the differences between the variants were not statistically confirmed ( $F_{\phi} < F_{\tau}$ ). The same tendency was observed in fruit buds. After foliar treatment with 1% solution of NPC “WPU Antifreeze” in fruit buds of the experimental variety,

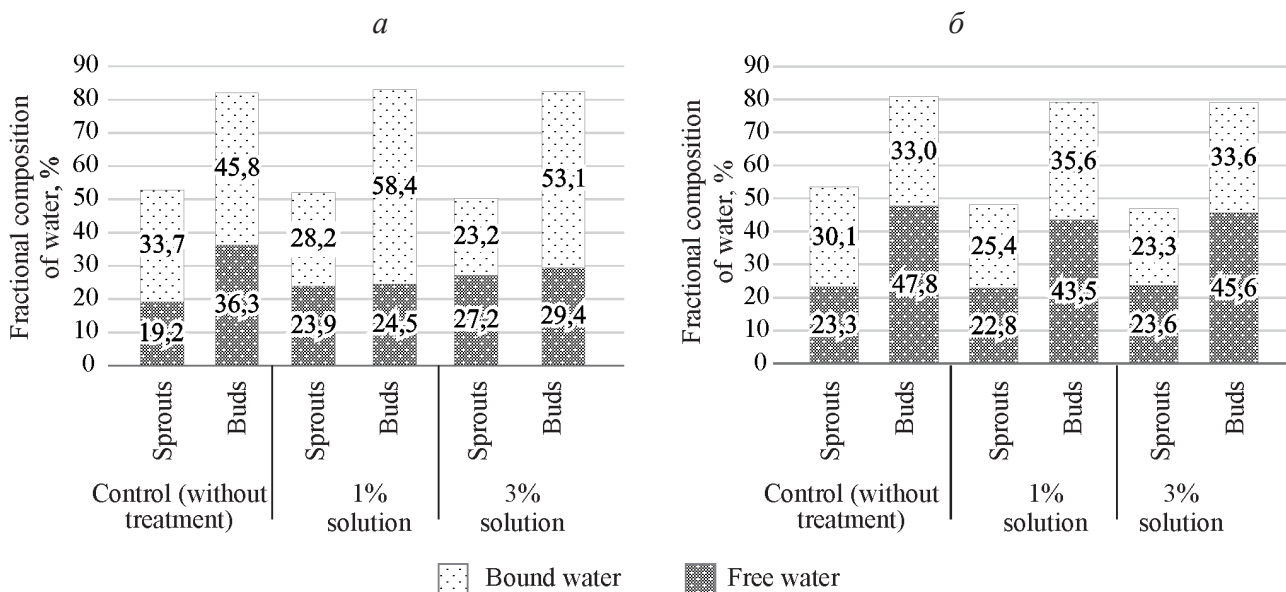

**Рис. 2.** Фракционный состав воды в тканях однолетних побегов и в плодовых почках в фенофазу «мышье око»: а – 2023 г.; б – 2024 г.

**Fig. 2.** Fractional composition of water in the tissues of annual shoots and in the fruit buds in the "Mouse's Eye" phenophase: а – 2023; б – 2024

a 4.0% decrease in the free water content and a 2.6% increase in the amount of bound water were recorded compared to the control. In another variant of the experiment (3% solution of the preparation) the content of free water in fruit buds decreased by 2.2%, and the amount of bound water increased by 1.1% relative to the control. At the same time, statistical differences between the variants were not confirmed ( $F_{\phi} < F_{\tau}$ ) (see fig. 2, б).

Subsequent treatments (May 2023) with 1% and 3% solutions of NPC “WPU Antifreeze” in the phenophase “closed inflorescence” increased, respectively, 1.6 and 1.5 times the content of free water in fruit buds, and, on the contrary, decreased 1.3 and 1.4 times compared to the previous phenophase. Probably, it is connected with the fact that the preparation increased the intensity of metabolism, increasing the share of free water in fruit buds, which plays an important role in physiological and biochemical processes taking place in plants in spring before the beginning of flowering. In the control, the content of free and bound water remained at the same level as in the “Mouse's Eye” phenophase (see fig. 3, a).

In 2024, during the “closed inflorescence phenophase”, an increase in the amount of free water was observed in fruit buds across all experimental variants compared to the previous phenophase (control – by 8.2%; 1% solution of the preparation – by 6.1%; 3% solution – by 1.8%). This is explained by the fact that plants require free water during the flowering period, as it determines the activity of physiological processes in the plant organism, serving as a universal solvent and transporter of nutrients. At the same time, the third foliar treatment with 1% and 3% solutions of the preparation contributed to an increase in the content of bound water in fruit buds by 2.0% and 9.5%, respectively, compared to the second treatment. This is important during spring frosts, as bound water has a lower freezing point compared to free water (see fig. 3, б). Thus, on average over two years, an increase in the proportion of bound water in fruit buds by 9.8% and 3.8% relative to the control was observed after the application of 1% and 3% solutions of NPC “WPU Antifreeze”.

In 2023, 1% solution (see Table 1) was the most effective concentration of the preparation



Рис. 3. Фракционный состав воды в плодовых почках в фенофазу «закрытое соцветие»: а – 2023 г.; б – 2024 г.

Fig. 3. Fractional composition of water in the fruit buds during the "closed inflorescence" phenophase: а – 2023; б – 2024

for increasing sucrose levels during the phenophase “dormant bud – silver cone“. For instance, in the bark of annual shoots, the sucrose level under the influence of the 1% solution exceeded the control by 15%, and in fruit buds, it increased by 19%. Treatment with the 3% solution did not have a significant effect on sucrose levels in the bark, while in the buds, it decreased by 2.4 times compared to the control. During the “Mouse's Eye” phenophase, the greatest reduction (by 3 times) in sucrose content compared to the previous phenophase was observed in the bark of annual shoots in the variant treated with the 1% solution of the preparation. This indicates that in this variant, a more intensive transport of substances to the buds began in the bark of annual shoots. After treatment with the 3% solution, the sucrose content decreased by 1.5 times. During the phenophase “closed inflorescence”, the sucrose content in all tissues continued to decline. A 1.5-fold decrease in carbohydrate content was observed in fruit buds after foliar treatments with the 1% solution of the preparation, which may indicate more intensive utilization of sugars for growth processes in this experimental variant.

In 2024, after the first treatment, the sucrose level increased by 16.9% and 25.3% for the vari-

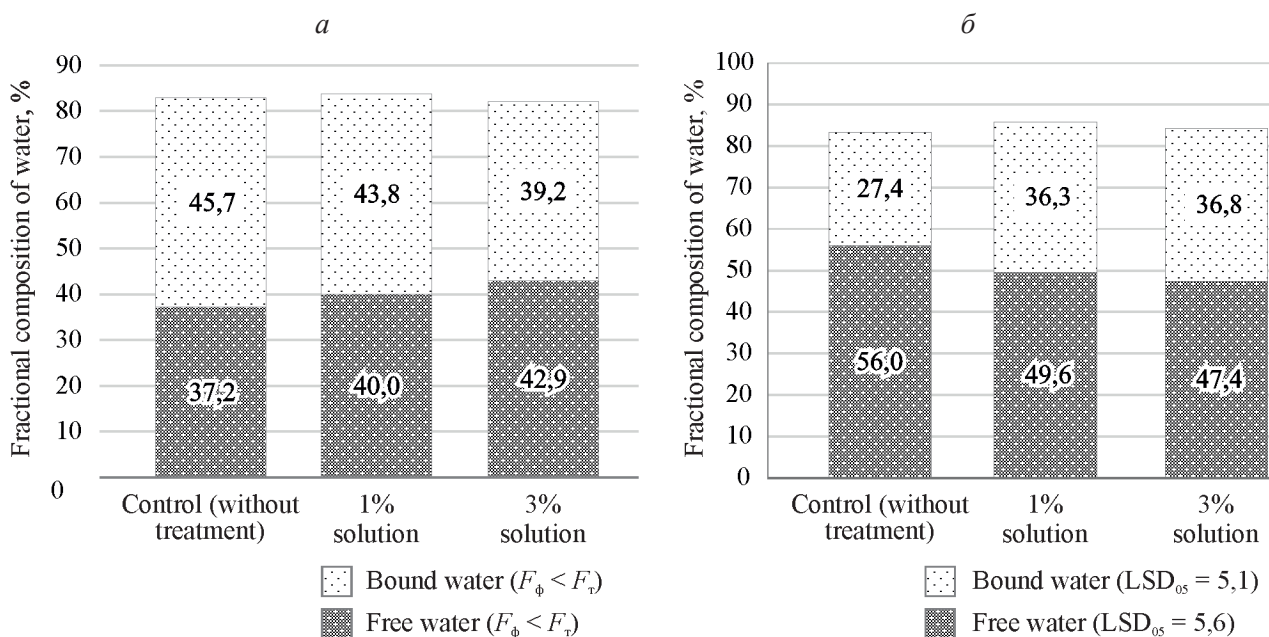
ants with the 1% and 3% solutions of the preparation, respectively, compared to the control (see Table 1). After the second treatment, conducted during the “Mouse's Eye” phenophase, the sucrose content in the bark tissues significantly decreased by 42.5% compared to the first treatment, but only in the variant with the 3% solution of the preparation. At the same time, a maximum reduction (by 67%) in sucrose levels was also observed in fruit buds, which may indicate increased consumption of sugars as a substrate for respiration and biosynthesis of plastic equivalents necessary for growth processes. Under the influence of the third treatment (phenophase “closed inflorescence”) with the 1% and 3% solutions of the preparation, the sucrose content in fruit buds increased by 23.1% and 55.6%, respectively, compared to the previous treatment date. Moreover, the sucrose level in flower buds in the treated variants exceeded the control by 45.5% and 27.3% (see Table 1). Thus, under the influence of the NPC “WPU Antifreeze” preparation over two years, the sucrose content in fruit buds increased by an average of 32.3%, which is expected to protect plant cells from frost damage during spring frosts.

**Табл. 1.** Влияние ПРК «БЖУ Антифриз» на содержание сахарозы в коре однолетних побегов и в плодовых почках, мг/г сухой массы

**Table 1.** Effect of the NPC "WPU Antifreeze" on sucrose content in the bark of annual shoots and in the fruit buds, mg/g of dry weight

Experiment option	Фенофаза					
	dormant bud - silver cone		Mouse's Eye		closed inflorescence	
	2023	2024	2023	2024	2023	2024
<i>Annual sprouts</i>						
Control (without treatment)	2,70 ± 0,10	0,83 ± 0,04	1,16 ± 0,05	0,76 ± 0,04	0,97 ± 0,04	0,68 ± 0,03
Solution NPC “WPU Antifreeze”:						
1%	3,10 ± 0,12	0,97 ± 0,05	1,03 ± 0,05	0,86 ± 0,04	1,00 ± 0,05	0,67 ± 0,03
3%	2,80 ± 0,11	1,04 ± 0,06	1,30 ± 0,06	0,73 ± 0,04	1,04 ± 0,04	0,87 ± 0,04
<i>Fruit buds</i>						
Control (without treatment)	0,78 ± 0,03	0,18 ± 0,01	0,21 ± 0,01	0,12 ± 0,01	0,16 ± 0,08	0,11 ± 0,01
Solution NPC “WPU Antifreeze”:						
1%	0,93 ± 0,04	0,20 ± 0,01	0,28 ± 0,01	0,13 ± 0,01	0,19 ± 0,09	0,16 ± 0,01
3%	0,32 ± 0,01	0,15 ± 0,01	0,22 ± 0,01	0,09 ± 0,01	0,22 ± 0,08	0,14 ± 0,01

The intensification of the growth processes is also evidenced by the pattern of free proline accumulation in plant tissues and organs. For instance, in 2023, during the phenophase “dormant bud – silver cone”, the proline content in both bark tissues and fruit buds did not differ between the experimental variants and the control. During the “Mouse's Eye” phenophase, the proline content in fruit buds of treated plants increased by 9.4 times (1% solution) and 8.2 times (3% solution) compared to the phenophase “dormant bud – silver cone”, while in the control, it increased by 7.8 times. The increase in proline content in fruit buds is associated with the onset of growth processes and the need for building materials for the synthesis of protein molecules. By the phenophase “closed inflorescence”, the greatest reduction in proline content was observed in the variant with the 3% solution of NPC “WPU Antifreeze” (by 8.3 times), while in the variant with the 1% solution, it decreased by 3.4 times compared to the end of April. In contrast, in the control, this indicator decreased by 2.5 times (see Table 2). The more intensive reduction in amino acid content in the experimental variants is likely related to active metab-

olism during growth and development, and consequently, the rapid incorporation of proline into protein molecules. As shown above, this is also consistent with the faster utilization of sugars required for plant respiration in the experimental variants.

In 2024, the first foliar treatment with the 1% solution of the preparation on the Sinap Orlovsky apple variety contributed to an increase in free proline content by 30.6% in the bark of annual shoots and by 46.3% in fruit buds compared to the control (see Table 2). At the same time, treatment with the 3% solution did not have a significant effect on the level of the amino acid in the bark of annual shoots or in the buds. After the second treatment (the “Mouse's Eye” phenophase), the greatest reduction in the amino acid was observed in the variant with the 1% solution of the preparation (96.7% compared to the previous phenophase), while in the control, the proline content decreased by 49.5%, and in the variant treated with the 3% solution, it decreased by 42.4%. It is important to note that against the background of a decrease in free proline levels in the bark tissues across all variants, an increase in its content was recorded in

**Табл. 2.** Влияние ПРК «БЖУ Антифриз» на содержание свободного пролина в коре однолетних побегов и в плодовых почках, мг/кг сырой массы

**Table 2.** Effect of the NPC "WPU Antifreeze" on the free proline content in the bark of annual shoots and in the fruit buds, mg/kg of crude weight

Experiment option	Phenophase					
	dormant bud - silver cone		Mouse's Eye		closed inflorescence	
	2023	2024	2023	2024	2023	2024
<i>Annual sprouts</i>						
Control (without treatment)	24,2 ± 0,9	16,38 ± 0,73	13,4 ± 0,5	10,96 ± 0,44	9,47 ± 0,3	10,60 ± 0,53
Solution NPC “WPU Antifreeze”:						
1%	23,5 ± 0,9	21,40 ± 0,85	12,7 ± 0,6	10,88 ± 0,51	9,20 ± 0,4	10,30 ± 0,51
3%	22,1 ± 1,1	16,86 ± 0,84	12,3 ± 0,6	11,84 ± 0,47	9,95 ± 0,4	10,72 ± 0,53
<i>Fruit buds</i>						
Control (without treatment)	21,4 ± 1,0	12,32 ± 0,55	167,1 ± 8,3	124,46 ± 5,62	66,4 ± 2,6	15,91 ± 0,72
Solution NPC “WPU Antifreeze”:						
1%	19,5 ± 0,9	18,03 ± 0,92	183,7 ± 7,3	122,13 ± 6,10	54,4 ± 2,1	13,22 ± 0,79
3%	21,9 ± 1,0	13,05 ± 0,63	179,2 ± 7,1	110,11 ± 5,50	21,6 ± 1,0	13,70 ± 0,19

fruit buds compared to the first treatment. The greatest increase in the amount of the amino acid (by 10.1 times) was observed in the control. After treatment with the 1% solution of the preparation, the proline content increased by 6.8 times, and after treatment with the 3% solution, it increased by 8.4 times compared to the phenophase “dormant bud – silver cone”. Apparently, the treatment with the preparation contributed to the modification of not only water and carbohydrate metabolism but also protein metabolism, particularly the biosynthesis and transport of proline. At the same time, the proline content in early May in the bark tissues in the variant with the 3% treatment decreased by 10.4%, while in the control and the variant with the 1% treatment, it remained unchanged compared to the “Mouse’s Eye” phenophase. In fruit buds (phenophase “closed inflorescence”), the proline level under the influence of the 3% solution of the preparation decreased by 8.0 times, in the variant with the 1% solution by 9.2 times, and in the control by 7.8 times compared to the previous phenophase (see Table 2).

Thus, over the two years of research, it has been shown that treatment with NPC “WPU Antifreeze” contributed to the acceleration of protein metabolism.

To assess the effect of the preparation on resistance to spring frosts, artificial freezing of flowers and buds was conducted at the beginning of flowering of the experimental apple variety Sinap Orlovsky. As a result of two years of research, it was found that at a temperature of  $-3^{\circ}\text{C}$ , treatment with the 1% and 3% solutions of the preparation reduced the proportion of dead flowers by 19.7% and 27.0%, respectively (see fig. 4, a), and the proportion of dead buds by 13.9% and 15.1% compared to the control (see fig. 4, б). After exposure to a temperature of  $-4^{\circ}\text{C}$ , treatment with the 1% and 3% solutions of the preparation contributed to a reduction in frost damage to flowers by 9.8% and 9.0%, and to buds by 9.1% and 10.5%, compared to the control variant. Thus, the positive effect of NPC “WPU Antifreeze” on the resistance of apple flowers and buds to spring frosts has been demonstrated, alongside an increase in the vol-

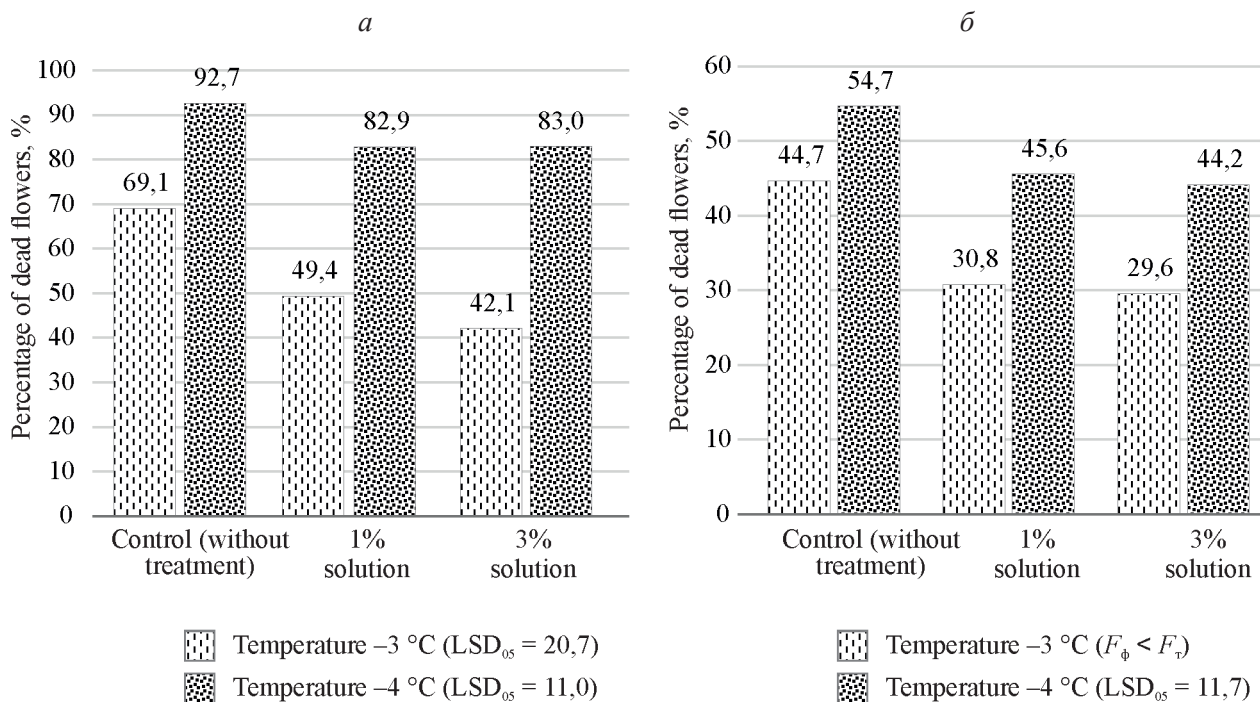

**Рис. 4.** Степень подмерзания цветков (а) и бутонов (б) яблони сорта Синап орловский в контролируемых условиях (среднее за 2023 и 2024 гг.)

**Fig. 4.** The degree of freezing of flowers (a) and buds (б) of the apple cultivar Sinap Orlovsky under controlled conditions (average for 2023 and 2024)

ume of bound water and the intensity of carbohydrate-protein metabolism.

It is also important to note that in the spring of 2024, extreme weather conditions unfavorable for fruit crops occurred. For example, in May, during the mass flowering period of apple trees, prolonged cooling with periodically recurring frosts was observed. The minimum air temperature dropped to  $-6^{\circ}\text{C}$  for the first time in the last 50 years (data from the meteorological station of the All-Russian Research Institute of Fruit Crop Breeding). The yield loss for most varieties amounted to 70–80%. At the same time, a positive effect of the NPC “WPU Antifreeze” preparation (under field conditions) on the resistance of flowers and buds of the Sinap Orlovsky apple variety was noted, which confirms the results of artificial freezing. For instance, in the control, the proportion of dead flowers was 78.2%. The application of the 1% and 3% solutions of the preparation reduced the number of frost-damaged flowers by 15.1% and 11.4%, respectively, compared to the control. It should be noted that the obtained experimental data are consistent with the results of earlier studies [12, 15].

## CONCLUSION

The effect of organomineral fertilizer NPC “WPU Antifreeze” on apple tree resistance to spring frosts was evaluated in soil and climatic conditions of the Orel region. According to the characteristics presented by the manufacturer, the preparation has adaptogenic properties. The priority in the use of adaptogenic preparations is a significant increase in adaptive properties of plants.

The conducted studies have shown that treatment with the NPC “WPU Antifreeze” preparation promotes an increase in the content of bound water, sucrose and proline in fruit buds. The increase in the content of low molecular weight osmolytes and bound water is of great importance in conditions of spring frosts, as it reduces the risk of dehydration and plant cell death. In particular, sugars along with proline increase the concentration of cell sap by increasing the level of bound water, which has a protective effect at negative temperatures.

The positive effect of the preparation of the NPC “WPU Antifreeze” on the resistance of flowers and buds of the apple variety Sinap Orlovsky was noted both in the laboratory and in the field conditions. According to the data of artificial freezing, foliar treatments with 1% and 3% solutions of the NPC “WPU Antifreeze” contributed to the reduction of flower and bud freezing compared to the control. In extreme conditions of spring 2024, the use of organomineral fertilizer contributed to increased resistance of apple trees to spring frosts, which is consistent with the data of laboratory studies. Thus, the use of adaptogenic preparation NPC “WPU Antifreeze” allows increasing resistance of generative buds of apple trees to spring frosts due to optimization of water regime and improvement of carbohydrate-protein metabolism.

## СПИСОК ЛИТЕРАТУРЫ

1. *Demirsoy H., Demirsoy L., Lang G.A.* Research on spring frost damage in cherries // Horticultural science (Prague). 2022. Vol. 49. P. 89–94. DOI: 10.17221/91/2021.
2. *Tadić V., Gligorević K., Mileusnić Z., Miodragović R., Hajmiler M., Radčajić D.* Agricultural engineering technologies in the control of frost damage in permanent plantations // AgriEngineering. 2023. Vol. 5. P. 2079–2111. DOI: 10.3390/agriengineering5040128.
3. *Szalay L., Bacos J.L., Toth M.* Frost hardiness of apple generative buds during dormancy // Acta agriculturae Slovenica. 2022. Vol. 118 (4). P. 1–7. DOI: 10.14720/aas.2022.118.4.2677.
4. *Rouphael Y., Colla G.* Editorial: Biostimulants in agriculture // Frontiers in plant science. 2020. Vol. 11. P. 40. DOI: 10.3389/fpls.2020.00040.
5. *Sangiorgio D., Cellini A., Donati I., Pastore C., Onofrietti C., Spinelli F.* Facing climate change: Application of microbial biostimulants to mitigate stress in horticultural crops // Agronomy. 2020. Vol. 10 (6). P. 794. DOI: 10.3390/agronomy10060794.
6. *Ali O., Ramsubhag A., Jayaraman J.* Biostimulant properties of seaweed extracts in plants: implications towards sustainable crop production // Plants. 2021. Vol. 10. P. 531. DOI: 10.3390/plants10030531.

7. Hassan I.A., El-Dakak R., Haiba N.S., Abd-Elmegeid W., El-Sheekh M., Abdul Rahman S., Basahi J., Summan A., Ismail I. Biochemical and physiological response of rice (*Oryza sativa* L.) plants to copper oxide nanoparticle stress // *Agrochimica*. 2021. Vol. 66 (1). P. 54–67. DOI: 10.12871/000218572020242.
8. Zulfiqar F., Casadesús A., Brockman H., Munne-Bosch S. An overview of plant-based natural biostimulants for sustainable horticulture with a particular focus on moringa leaf extracts // *Plant science*. 2020. Vol. 295. P. 110194. DOI: 10.1016/j.plantsci.2019.110194.
9. Franzoni G., Bulgari R., Ferrante A. Maceration time affects the efficacy of borage extracts as potential biostimulant on rocket salad // *Agronomy*. 2021. Vol. 11. P. 2182. DOI: 10.3390/agronomy11112182.
10. Franzoni G., Cocetta G., Prinsi B., Ferrante A., Espen L. Biostimulants on crops: Their impact under abiotic stress conditions // *Horticulturae*. 2022. Vol. 8 (3). P. 189. DOI: 10.3390/horticulturae8030189.
11. Lau S.E., Teo W.F.A., Teoh E.Y., Tan B.C. Microbiome engineering and plant biostimulants for sustainable crop improvement and mitigation of biotic and abiotic stresses // *Discover food*. 2022. Vol. 2. P. 9. DOI: 10.1007/s44187-022-00009-5.
12. Ожерельева З.Е., Прудников П.С. Влияние биопрепаратов ПРК «Белый Жемчуг» линии В-PLUS на устойчивость к весенним заморозкам, урожайность и качество плодов яблони // *Садоводство и виноградарство*. 2022. № 6. С. 24–32. DOI: 10.31676/0235-2591-2022-6-24-32.
13. Sorrentino M., De Diego N., Ugena L., Spichal L., Lucini L., Miras-Moreno B., Zhang L., Rouphael Y., Colla G., Panzarová K. Seed priming with protein hydrolysates improves arabidopsis growth and stress tolerance to abiotic stresses // *Frontiers in plant science*. 2021. Vol. 12. P. 626301. DOI: 10.3389/fpls.2021.626301.
14. Erb M., Kliebenstein D.J. Plant secondary metabolites as defenses, regulators, and primary metabolites: The blurred functional trichotomy // *Plant physiology*. 2020. Vol. 184. P. 39–52. DOI: 10.1104/pp.20.00433.
15. Ozherelieva Z., Prudnikov P., Nikitin A., Androsova A., Bolgova A., Stupina A., Vetrova O. Adaptogenic preparations enhance the tolerance to spring frosts, yield and quality of apple fruits // *Horticulturae*. 2023. Vol. 9 (5). P. 591. DOI: 10.3390/horticulturae9050591.

## REFERENCES

1. Demirsoy H., Demirsoy L., Lang G.A. Research on spring frost damage in cherries. *Horticultural science (Prague)*, 2022, vol. 49, pp. 89–94. DOI: 10.17221/91/2021.
2. Tadić V., Gligorević K., Mileusnić Z., Miodragović R., Hajmiler M., Radóčaj D. Agricultural engineering technologies in the control of frost damage in permanent plantations. *AgriEngineering*, 2023, vol. 5, pp. 2079–2111. DOI: 10.3390/agriengineering5040128.
3. Szalay L., Bacos J.L., Toth M. Frost hardiness of apple generative buds during dormancy. *Acta agriculturae Slovenica*, 2022, vol. 118 (4), pp. 1–7. DOI: 10.14720/aas.2022.118.4.2677.
4. Rouphael Y., Colla G. Editorial: Biostimulants in agriculture. *Frontiers in plant science*, 2020, vol. 11, p. 40. DOI: 10.3389/fpls.2020.00040.
5. Sangiorgio D., Cellini A., Donati I., Pastore C., Onofrietti C., Spinelli F. Facing climate change: Application of microbial biostimulants to mitigate stress in horticultural crops. *Agronomy*, 2020, vol. 10 (6), p. 794. DOI: 10.3390/agronomy10060794.
6. Ali O., Ramsabhadra A., Jayaraman J. Biostimulant properties of seaweed extracts in plants: implications towards sustainable crop production. *Plants*, 2021, vol. 10, p. 531. DOI: 10.3390/plants10030531.
7. Hassan I.A., El-Dakak R., Haiba N.S., Abd-Elmegeid W., El-Sheekh M., Abdul Rahman S., Basahi J., Summan A., Ismail I. Biochemical and physiological response of rice (*Oryza sativa* L.) plants to copper oxide nanoparticle stress. *Agrochimica*, 2021, vol. 66 (1), p. 54–67. DOI: 10.12871/000218572020242.
8. Zulfiqar F., Casadesús A., Brockman H., Munne-Bosch S. An overview of plant-based natural biostimulants for sustainable horticulture with a particular focus on moringa leaf extracts. *Plant science*, 2020, vol. 295, p. 110194. DOI: 10.1016/j.plantsci.2019.110194.
9. Franzoni G., Bulgari R., Ferrante A. Maceration time affects the efficacy of borage extracts as potential biostimulant on rocket salad. *Agronomy*, 2021, vol. 11, p. 2182. DOI: 10.3390/agronomy11112182.
10. Franzoni G., Cocetta G., Prinsi B., Ferrante A., Espen L. Biostimulants on crops: Their impact under abiotic stress conditions. *Horticulturae*, 2022, vol. 8 (3), p. 189. DOI: 10.3390/horticulturae8030189.

11. Lau S.E., Teo W.F.A., Teoh E.Y., Tan B.C. Microbiome engineering and plant biostimulants for sustainable crop improvement and mitigation of biotic and abiotic stresses. *Discover food*, 2022, vol. 2, p. 9. DOI: 10.1007/s44187-022-00009-5.
12. Ozherelieva Z.E., Prudnikov P.S. Impact of the B-Plus white pearl (Belyi Zhemchug) preparation on the spring frost tolerance, yield and quality of apple crops. *Sadovodstvo i vinigradorstvo = Horticulture and viticulture*, 2022, no. 6, pp. 24–32. (In Russian). DOI: 10.31676/0235-2591-2022-6-24-32.
13. Sorrentino M., De Diego N., Ugena L., Spíchal L., Lucini L., Miras-Moreno B., Zhang L., Rouphael Y., Colla G., Panzarová K. Seed priming with protein hydrolysates improves arabidopsis growth and stress tolerance to abiotic stresses. *Frontiers in plant science*, 2021, vol. 12, p. 626301. DOI: 10.3389/fpls.2021.626301.
14. Erb M., Kliebenstein D.J. Plant secondary metabolites as defenses, regulators, and primary metabolites: The blurred functional trichotomy. *Plant physiology*, 2020, vol. 184, p. 39–52. DOI: 10.1104/pp.20.00433.
15. Ozherelieva Z., Prudnikov P., Nikitin A., Androsova A., Bolgova A., Stupina A., Vetrova O. Adaptogenic preparations enhance the tolerance to spring frosts, yield and quality of apple fruits. *Horticulturae*, 2023, no. 9 (5), p. 591. DOI: 10.3390/horticulturae9050591.

#### ИНФОРМАЦИЯ ОБ АВТОРАХ

✉ **Ожерельева З.Е.**, кандидат сельскохозяйственных наук, ведущий научный сотрудник; **адрес для переписки:** Россия, 302530, Орловская область, д. Жилина; e-mail: ozherelieva@orel.vniispk.ru

**Прудников П.С.**, кандидат биологических наук, старший научный сотрудник

**Ступина А.Ю.**, младший научный сотрудник

**Болгова А.О.**, аспирант, младший научный сотрудник

#### AUTHOR INFORMATION

✉ **Zoya E. Ozherelieva**, Candidate of Science in Agriculture, Lead Researcher; **address:** Zhilina village, Orel Region, 302530, Russia; e-mail: ozherelieva@orel.vniispk.ru

**Pavel S. Prudnikov**, Candidate of Science in Biology, Senior Researcher

**Anna Yu. Stupina**, Junior Researcher

**Anzhelika O. Bolgova**, Post-graduate Student, Junior Researcher

Дата поступления статьи / Received by the editors 20.06.2024  
Дата принятия к публикации / Accepted for publication 19.08.2024  
Дата публикации / Published 20.11.2024



<https://doi.org/10.26898/0370-8799-2024-10-7>

УДК: 632.9

Тип статьи: оригинальная

Type of article: original

## Эффективность бактерий-антагонистов *Bacillus* и *Pseudomonas* в качестве агентов биоконтроля сетчатой пятнистости озимого ячменя в полевых условиях

Асатурова А.М., Жевнова Н.А., Сидоров Н.М., Кремнева О.Ю.

Федеральный научный центр биологической защиты растений

Краснодар, Россия

✉ e-mail: n.zhevnova@mail.ru

Сетчатая пятнистость листьев ячменя – широко распространенная в мире болезнь зерновых культур, наносящая значительный экономический ущерб. Преимущественным способом борьбы с ней остается химическая защита, имеющая множество негативных последствий. Необходимо отметить, что возбудитель болезни – гриб *Pyrenophora teres* – относится к классу патогенов с высокой вероятностью развития множественной резистентности сразу к нескольким химическим фунгицидам. В связи с этим в работе исследовано защитное действие штаммов *Bacillus velezensis* BZR 336 g и BZR 517, а также *Pseudomonas chlororaphis* BZR 245 F на двух сортах ячменя озимого с различной устойчивостью к возбудителю сетчатой пятнистости в условиях двухлетних полевых испытаний. Установлено, что обработка указанными штаммами снижала развитие сетчатой пятнистости в среднем на 26–30% в условиях центральной зоны Краснодарского края. В 2022 г. штаммы смогли конкурировать по эффективности с химическим эталоном. Выявлено, что на восприимчивом сорте Романс снижение развития болезни при обработке штаммами было более выраженным – в среднем 25,7–38,8% при 20,9–25,3% на устойчивом сорте Иосиф. Определено, что обработка жидкими культурами штаммов перед посевом и в период вегетации эффективнее, чем другие способы. В 2018 г. обработка семян и растений штаммами была эффективнее других способов: на сорте Иосиф – в среднем на 6–8%, на сорте Романс – на 8–24%. В 2022 г. обработка семян и растений штаммами была в среднем на 12–17 (Иосиф) и 35–38% (Романс) эффективнее, чем другие методы обработки. Биологическая эффективность штаммов зависела от климатических факторов. В благоприятных погодных условиях максимальное снижение развития болезни отмечено при использовании штамма рода *Pseudomonas*, в условиях нестабильного метеорологического фона наибольшую эффективность продемонстрировали биоагенты рода *Bacillus*. Результаты исследований показали, что биологические методы борьбы с сетчатой пятнистостью листьев озимого ячменя достаточно эффективны и требуют дальнейшей реализации. Биологические средства защиты растений помимо подавления вредоносности фитопатогенов будут способствовать получению экологически безопасной продукции в совокупности со снижением пестицидного пресса на агроценозы.

**Ключевые слова:** *Pyrenophora teres*, *Bacillus*, *Pseudomonas*, бактерии-антагонисты, биологическая защита растений, зерновые культуры

## Efficacy of *Bacillus* and *Pseudomonas* antagonist bacteria as biocontrol agents of barley net blotch in field conditions

Asaturova A.M., Zhevnova N.A., Sidorov N.M., Kremneva O.Yu.

Federal Research Center of Biological Plant Protection

Krasnodar, Russia

✉ e-mail: n.zhevnova@mail.ru

Barley net blotch is a widespread disease of cereal crops worldwide, causing significant economic losses. The predominant method of controlling it remains chemical defense, which has many nega-

tive consequences. It should be noted that the causative agent of the disease, the fungus *Pyrenophora teres*, belongs to the class of the pathogens with a high probability of developing multiple resistance to several chemical fungicides at once. In this regard, the protective effect of *Bacillus velezensis* strains BZR 336 g and BZR 517, as well as *Pseudomonas chlororaphis* BZR 245 F on two varieties of winter barley with different resistance to the causative agent of net blotch in two-year field trials was investigated. It was found that treatment with the above strains reduced the development of net blotch on average by 26–30% in the conditions of the central zone of the Krasnodar Territory. In 2022, the strains were able to compete in efficiency with the chemical reference. It was found that the reduction of disease development was more pronounced on the susceptible variety Romance when treated with the strains, with an average of 25.7–38.8% compared to 20.9–25.3% on the resistant variety Iosif. It was determined that treatment with liquid strain cultures before sowing and during the growing season is more effective than other methods. In 2018, seed and plant treatment with the strains was more effective than other methods: on the variety Iosif by an average of 6–8% and on the variety Romance by 8–24%. In 2022, seed and plant treatments with the strains were on average 12–17 (Iosif) and 35–38% (Romance) more effective than other methods of treatment. The biological efficacy of the strains depended on climatic factors. In favorable weather conditions, the maximum reduction of disease development was observed with the use of strain of the *Pseudomonas* genus, in conditions of unstable meteorological background the greatest efficiency was demonstrated by bioagents of the *Bacillus* genus. The results of research have shown that biological methods of controlling winter barley net blotch are quite effective and require further implementation. Biological means of plant protection in addition to suppressing the harmfulness of phytopathogens will contribute to the production of environmentally safe products in conjunction with the reduction of pesticide pressure on agrocenoses.

**Keywords:** *Pyrenophora teres*, *Bacillus*, *Pseudomonas*, antagonist bacteria, biological plant defence, cereal crops

**Для цитирования:** Асатурова А.М., Жевнова Н.А., Сидоров Н.М., Кремнева О.Ю. Эффективность бактерий-антагонистов *Bacillus* и *Pseudomonas* в качестве агентов биоконтроля сетчатой пятнистости озимого ячменя в полевых условиях // Сибирский вестник сельскохозяйственной науки. 2024. Т. 54. № 10. С. 69–77. <https://doi.org/10.26898/0370-8799-2024-10-7>

**For citation:** Asaturova A.M., Zhevnova N.A., Sidorov N.M., Kremneva O.Yu. Efficacy of *Bacillus* and *Pseudomonas* antagonist bacteria as biocontrol agents of barley net blotch in field conditions. *Sibirskii vestnik sel'skokhozyaistvennoi nauki = Siberian Herald of Agricultural Science*, 2024, vol. 54, no. 10, pp. 69–77. <https://doi.org/10.26898/0370-8799-2024-10-7>

#### Конфликт интересов

Авторы заявляют об отсутствии конфликта интересов.

#### Conflict of interest

The authors declare no conflict of interest.

#### Благодарность

Исследования выполнены согласно государственному заданию Министерства науки и высшего образования Российской Федерации в рамках НИР по теме № FGRN-2022-0006.

#### Acknowledgements

The research was carried out according to the state assignment of the Ministry of Science and Higher Education of the Russian Federation within the framework of the research work under the topic No. FGRN-2022-0006.

## INTRODUCTION

Net blotch of barley, caused by the heterothallic ascomycete *Pyrenophora teres* Drechsler (anamorph: *Drechslera teres* Sacc. (Shoem.) = *Helminthosporium teres*), is one of the most harmful diseases and is found in almost all countries engaged in grain cultivation. This is due to the high adaptability of the pathogen and active

microevolutionary processes [1–4]. In years of epiphytotic, yield losses from this disease can reach 20–40% or more [2–4].

The disease affects leaves, leaf sheaths, and stems (see the figure). As the disease progresses, the photosynthetic area of the leaf decreases, which can lead to complete necrosis and desiccation of the plant. The widespread distribution



Сетчатая пятнистость листьев озимого ячменя  
Winter barley net blotch disease

of the infection is facilitated by high humidity, the use of susceptible varieties, monoculture in crop rotation, and an abundance of plant residues [1–5].

Currently, the chemical method remains the most widely used approach to suppress the disease [1, 6]. However, due to the peculiarities of its genetic apparatus, the pathogen can quickly develop resistance to the most common and widely used fungicides. Resistance to fungicides of various chemical groups is observed everywhere due to the intensification of agricultural production [3, 4]. The practice of using chemical agents to combat diseases has shown that their economic efficiency is gradually declining. Pathogens resistant to pesticides are emerging, the costs of developing new drugs are increasing, and ultimately, this raises the cost of agricultural production. The constant use of chemical plant protection products disrupts biological balance, pollutes the environment, and leads to the accumulation of toxic residues in soil, water bodies, groundwater, and agricultural products [7].

Environmentally safe biopreparations based on microorganisms of various taxonomic groups are an alternative to the chemical method. The

advantages of biological plant protection agents include their safety for warm-blooded organisms and the environment, selectivity of action, absence or weak phytotoxicity, low probability of resistance development in case of long-term application [8–10].

Numerous studies confirm the effectiveness of microorganisms in the control of plant diseases, including the use of resistant varieties [4, 11–15]. Thus, E. O'Brien<sup>1</sup> reports on *P. fluorescens* strains MKB100 and MKB156, *Pseudomonas* sp. MKB158 and MKB194, which significantly (up to 46%) reduced disease development under natural conditions on two barley varieties. A study by A. Perello et al.<sup>2</sup> showed up to 56% reduction of disease development caused by the taxonomically similar pathogen *P. tritici-repentis* using biocontrol strains on wheat leaves under field conditions. Some variants gave good protective effect even compared to fungicide treatment. M. Ghorbanpour et al. [16] evaluated the effect of *Pseudomonas* and *Bacillus* strains on the development of barley net blotch caused by *P. graminea* in field conditions for two years on three varieties differing in the degree of resistance. The level of disease development was reduced to 66%.

Conducting research in the direction of biologization of plant protection systems is promising in connection with the adoption of the Strategy for the development of organic production in the Russian Federation until 2030, which provides for the active development of agrobiotechnological direction<sup>3</sup>.

The purpose of this study was to investigate the ability of bacterial bioagents of two different genera (*Bacillus* and *Pseudomonas*) to control the development of net blotch on two winter barley varieties differing in disease resistance under varying environmental conditions.

<sup>1</sup>O'Brien E. Biological control of *Pyrenophora teres*. Letterkenny, 2005, 104 p.

<sup>2</sup>Perello A., Moreno V., Monaco C., Simon M.R. Effect of *Trichoderma* spp. isolates for biological control of tan spot of wheat caused by *Pyrenophora tritici-repentis* under field conditions in Argentina // *Biocontrol*, 2008, N 53, pp. 895–904.

<sup>3</sup>Order of the Government of the Russian Federation from 04.07.2023, № 1788 r “On approval of the Strategy for the development of organic production in the Russian Federation until 2030” (<https://www.garant.ru/products/ipo/prime/doc/407297286/>).

## MATERIAL AND METHODS

The research was conducted at the field experimental base of the Federal Research Center of Biological Plant Protection (FSBSI FRCBPP) in 2017–2018 and 2021–2022. Two winter barley varieties of the selection of the National Grain Center P.P. Lukyanenko, differing in the degree of resistance to net blotch were used: Romance (susceptible, the level of disease development 30–50%), Iosif (resistant, the level of disease development up to 20%) [12]. Plants were grown on the plots with the area of 5 m<sup>2</sup>. The total area of the experiment amounted to 1100 m<sup>2</sup>.

The research objects were strains from the bioresource collection of the “State Collection of Entomocariphages and Microorganisms” of the FSBSI Federal Research Center of Biological Plant Protection: *Pseudomonas chlororaphis* BZR 245 F, *Bacillus velezensis* BZR 336 g and BZR 517. The strains were selected by the method of stepwise screening and on the basis of experimental data were recognized as promising for the creation of biological preparations [13].

Liquid cultures (LC) of the above strains obtained by batch cultivation in New Brunswick Scientific Excella E25 shaker incubators (Enfield, USA) (180 rpm) were used in the study. Strains BZR 336 g and BZR 517 were obtained on the original optimized nutrient medium for 48 h at 25 °C and 36 h at 30 °C, respectively<sup>4</sup>. Cell concentration was maintained at the level of  $2,8 \cdot 10^8$ – $4,1 \cdot 10^9$  CFU/ml.

BZR 245 F strain was obtained by the same method on King's B medium for 36 h at 26 °C, cell concentration  $1,6 \cdot 10^8$ – $2,4 \cdot 10^9$  CFU/ml.

The strains were used in three ways:

- 1) pre-sowing seed treatment and subsequent treatment of vegetative plants;
- 2) treatment of vegetative plants;

3) seed treatment; treatment of vegetative plants was carried out in spring in the tillering phase (Z 26-21).

The application rates of LC strains were as follows: seed treatment with strain BZR 245 F – 2 l/t, BZR 336 g – 3 l/t, BZR 517 – 2 l/t, plant treatment – 2, 3 and 2 l/ha, respectively. Consumption of the working fluid was 10 l/t and 300 l/ha. Kinto Duo, SC (triticonazole + prochloraz, 20 + 60 g/l) was used as a chemical standard for seed treatment, Alto Super, SC (propiconazole + cyproconazole, 250 g/l + 80 g) for plant treatment. Alirin-B, L (*B. subtilis*, strain VIZR B-10) was used as a biological standard.

Disease development was evaluated visually in dynamics as the symptoms appeared. The level of disease development was recorded in percentages by determining the ratio of the affected areas to the total leaf area. The data obtained at maximum development of the disease are presented in the paper. Biological efficiency was calculated using the Abbott formula<sup>5</sup>

$$BE = (100 \cdot (P - p))/P,$$

where BE – biological effectiveness, %; P – data in the control, %; p – data in the variant with a bioagent or benchmark application, %.

The growing season from October 2017 through June 2018 was favorable for the plants and biological agents (based on the weather archive, weather station No 34920<sup>6</sup>).

During this period, there were no sharp fluctuations in precipitation levels or air temperature. The autumn and winter were warm (5.2...12.2 °C). Plants received ample moisture during the initial stages of vegetation (70–148 mm of precipitation fell). Vegetation resumed in March. In the autumn of 2021, after sowing, the air temperature was low (down to –1.3 °C), and plants

<sup>4</sup>Asaturova A.M., Homyak A.I., Tomashevich N.S., Pavlova M.D., Zhevnova N.A., DUBYAGA V.M., KOZITSIN A.Ye., SIDOROVA T.M., NADYKTA V.D., ISMAILOV V.Ya. Conditions for the cultivation of new *Bacillus* bacteria being micro bioproduct producers // Journal of pure and applied microbiology, 2015, N 9 (4), pp. 2797–2804.

<sup>5</sup>Abbott W.S. A method of computing the effectiveness of an insecticide // Journal of Economic Entomology, 1925, vol. 18, N 2, pp. 265–267.

<sup>6</sup><https://rp5.ru/>

received little moisture (40–56 mm). During the winter, there were sharp fluctuations in temperature (from –12.1 to –19.0 °C) and precipitation (from 37 to 166 mm). The spring of 2022 was cold, and vegetation resumed in mid-April.

The material and technical base of USU “Technological line for production of microbiological plant protection agents of new generation”<sup>7</sup> was used in the research. Statistical processing of data was carried out using Tukey HSD STATISTICA 13.2 test (StatSoft Russia). Repetition in all the experiments was threefold.

## RESULTS AND DISCUSSION

Biological efficiency varied depending on the level of infection background, variety and the method of application of LC strains. In 2018, the development of net blotch was 4.8–5.8% on the resistant variety Iosif and 22.6–35.8% on the susceptible variety Romance. In 2022, the natural infection background was more aggressive with 63.1–66.4% on variety Iosif and 71.1–73.2% on variety Romance. In 2018, maximum reduction in disease development occurred with the use of chemical protection (irrespective of the method of application). In 2022, biological protection was most effective, in particular strains BZR 517 and BZR 245 F maximally reduced disease development (see the Table).

Pre-sowing seed treatment combined with treatment of vegetating plants proved to be more effective than other types of treatment. In 2018, when treating seeds and plants of the Iosif variety with the strains, the biological efficacy was 16.3–32.0%, which was on average 6–8% higher than when using other methods. For the susceptible variety Romance, the difference was more pronounced: on average, the strains suppressed the disease by 8–24% better when treating seeds and plants compared to other treatment methods. In 2022, the treatment of seeds and plants with the strains was on average 12–17% (Iosif) and 35–38% (Romance) more effective than other treatment methods (see the Table).

The efficacy of the strains varied. In 2018, the strain BZR 245 F reduced disease development by 15.2–59.9%, depending on the variety and treatment method, surpassing this indicator in variants using strains of the genus *Bacillus*. The efficacy of BZR 336 g and BZR 517 was lower, at 4.2–53.7%. In 2022, BZR 245 F showed maximum efficacy only on the resistant variety, while BZR 336 g and BZR 517 significantly suppressed pathogen development on both varieties: by 16.2–49.7% on the resistant variety Iosif and by 6.1–46.9% on the susceptible variety Romans. It is worth noting that the strains were able to compete in efficacy with the chemical standard in 2022 (see the Table).

It was observed that under field conditions, the biological efficacy of the strains depended on weather conditions. In the favorable weather conditions of 2017 and 2018, the strain BZR 245 F suppressed the development of net blotch more actively than the bacillary strains. The biological efficacy of the strain BZR 245 F was 24.6–59.9%, while that of strains BZR 336 g and BZR 517 was 4.2–50.3% (see table). In 2021–2022, the climatic conditions were less stable than in the previous research period. In 2022, the biological efficacy of strains BZR 336 g and BZR 517 was on average 7–19% higher than that of BZR 245 F, which was particularly noticeable on the susceptible variety Iosif. Additionally, under field trial conditions in 2022, the strains were able to compete in efficacy with the chemical standard.

## CONCLUSION

It was found that treatment with the strains reduced the development of barley net blotch by an average of 30% in 2018 and by 26% in 2022. It is worth noting that in 2022, the strains were able to compete in efficacy with the chemical reference.

It was found that treatment with LC strains before sowing and during the growing season was more effective than other methods. In

<sup>7</sup><http://ckp-rf.ru/usu/671367>

Развитие сетчатой пятнистости (R, %) и биологическая эффективность (BE, %) штаммов в условиях полевой экспериментальной базы ФГБНУ ФНЦБЗР  
Development of net blotch (R, %) and biological efficacy (BE, %) of strains under the conditions of the field experimental base of the FRCBPP

Treatment method	Experiment option	2018				2022			
		Variety Iosif		Variety Romance		Variety Iosif		Variety Romance	
		R	BE	R	BE	R	BE	R	BE
Seed and plant treatment	Control	5,7 <sup>c</sup>	–	23,4 <sup>c</sup>	–	63,6 <sup>c</sup>	–	72,2 <sup>d</sup>	–
	Chemical standard	3,8 <sup>a</sup>	33,1	4,6 <sup>a</sup>	80,4	46,5 <sup>a</sup>	26,9	53,2 <sup>c</sup>	26,3
	Biological reference	4,2 <sup>a</sup>	27,3	10,1 <sup>a, b</sup>	57,0	44,3 <sup>a</sup>	30,3	34,5 <sup>a, b</sup>	52,2
	BZR 245 F	3,9 <sup>a</sup>	32,0	9,4 <sup>a, b</sup>	59,9	48,7 <sup>a</sup>	23,5	27,3 <sup>b</sup>	62,2
	BZR 336 g	4,2 <sup>a</sup>	26,7	11,6 <sup>a, b</sup>	50,3	43,9 <sup>a</sup>	30,9	42,3 <sup>a</sup>	41,3
	BZR 517	4,8 <sup>a</sup>	16,3	16,3 <sup>b, c</sup>	30,5	32,0 <sup>b</sup>	49,7	38,3 <sup>a</sup>	46,9
Plant treatment	Control	5,8 <sup>b</sup>	–	27,8 <sup>b</sup>	–	66,4 <sup>c</sup>	–	73,2 <sup>a</sup>	–
	Chemical standard	3,7 <sup>c</sup>	36,6	13,1 <sup>a</sup>	53,0	57,3 <sup>a</sup>	13,8	49,3 <sup>b</sup>	32,7
	Biological reference	5,3 <sup>b</sup>	9,1	20,4 <sup>a, b</sup>	26,6	53,4 <sup>a, b</sup>	19,6	55,3 <sup>b, c</sup>	24,4
	BZR 245 F	4,4 <sup>a</sup>	24,6	14,0 <sup>a</sup>	49,6	57,2 <sup>a</sup>	13,9	62,3 <sup>a, c</sup>	14,8
	BZR 336 g	4,6 <sup>a</sup>	21,7	16,8 <sup>a</sup>	39,4	50,4 <sup>b</sup>	24,1	63,0 <sup>a, c</sup>	13,9
	BZR 517	4,7 <sup>a</sup>	20,0	16,9 <sup>a</sup>	39,1	55,5 <sup>a, b</sup>	16,4	67,4 <sup>a</sup>	7,9
Seed treatment	Control	4,8 <sup>a</sup>	–	22,6 <sup>b</sup>	–	63,1 <sup>c</sup>	–	71,1 <sup>b</sup>	–
	Chemical standard	2,2 <sup>a</sup>	53,8	12,5 <sup>a</sup>	44,7	56,0 <sup>a</sup>	11,2	80,5 <sup>c</sup>	0,0
	Biological reference	3,3 <sup>a</sup>	30,1	15,7 <sup>a</sup>	30,7	57,9 <sup>a, c</sup>	8,2	65,8 <sup>a, b</sup>	7,4
	BZR 245 F	3,3 <sup>a</sup>	30,1	19,2 <sup>a, b</sup>	15,2	49,4 <sup>b</sup>	21,7	64,4 <sup>a</sup>	9,4
	BZR 336 g	4,6 <sup>a</sup>	4,2	13,8 <sup>a</sup>	38,9	43,6 <sup>d</sup>	30,9	50,5 <sup>c</sup>	29,0
	BZR 517	4,2 <sup>a</sup>	12,6	16,7 <sup>a, b</sup>	26,3	52,8 <sup>a, b</sup>	16,2	66,8 <sup>a, b</sup>	6,1

Note. Different letters indicate valid differences ( $p < 0,05$ ) within a column according to the test Tukey HSD.

2018, treatment of seeds and plants of Iosif variety with the strains reduced development of net blotch by 6–8% more effective than other methods, on the Romance variety – by 8–24% more effective. In 2022, seed and plant treatment with strains was on average 12–17 (Iosif) and 35–38% (Romance) more effective relative to other treatments.

It was found that on the susceptible variety Romance the reduction of disease development when treated with the strains was more pronounced with an average of 25.7–38.8% with 20.9–25.3% on the resistant variety Iosif.

It was determined that in field conditions the

biological efficiency of the strains depended on the weather conditions. In a favorable weather period (2017-2018) strain BZR 245 F suppressed the development of net blotch more actively than *Bacillus* strains. In the less stable period (2021-2022), the biological efficacy of *Bacillus* strains was on average 7–19% higher than that of BZR 245 F, which was especially noticeable on the susceptible variety Iosif.

The conducted research has shown that biological methods of control of winter barley net blotch are quite effective and require further implementation in production conditions. Biological means of plant protection against diseases will not only

reduce the harmfulness of *P. teres*, but will also contribute to the production of environmentally safe products in conjunction with the reduction of pesticide pressure on the agrocenoses.

## СПИСОК ЛИТЕРАТУРЫ

1. Мироненко Н.В., Орина А.С., Коваленко Н.М. Генетический полиморфизм штаммов ToxB+ *Pyrenophora tritici-repentis* // Экологическая генетика. 2021. Т. 19. № 2. С. 121–129. DOI: 10.17816/ecogen54718.
2. Volkova G., Yakhnik Ya. *Pyrenophora teres*: Population structure, virulence and aggressiveness in Southern Russia // Saudi journal of biological sciences. 2022. Vol. 29. N 10. P. 103401. DOI: 10.1016/j.sjbs.2022.103401.
3. Яхник Я.В., Волкова Г.В. Чувствительность возбудителя сетчатой пятнистости листьев (*Pyrenophora teres*) к двухкомпонентным фунгицидам на основе триазолового и стробилуринового классов // Известия Тимирязевской сельскохозяйственной академии. 2024. № 2. С. 127–138. DOI: 10.26897/0021-342X-2024-2-127-138.
4. Backes A., Guerriero G., Ait Barka E., Jacquard C. *Pyrenophora teres*: taxonomy, morphology, interaction with barley, and mode of control // Frontiers in plant science. 2021. N 12. P. 614951. DOI: 10.3389/fpls.2021.614951.
5. Мироненко Н.В., Лашина Н.М., Баранова О.А., Зубкович А.А., Афанасенко О.С. Гибридизация между формами *Pyrenophora teres* в природных популяциях России и Республики Беларусь // Микология и фитопатология. 2021. Т. 55. № 1. С. 51–58. DOI: 10.31857/S0026364821010074.
6. McLean M.S., Poole N., Santa I.M., Hollaway G.J. Efficacy of spot form of net blotch suppression in barley from seed, fertilizer and foliar applied fungicides // Crop Protection. 2022. N 153. P. 105865. DOI: 10.1016/j.cropro.2021.105865.
7. Azizbekyan R.R. Biological preparations for the protection of agricultural plants (review) // Applied biochemistry and microbiology. 2019. Vol. 55. N 8. P. 816–823. DOI: 10.1134/S0003683819080027.
8. Павлюшин В.А., Новикова И.И., Бойкова И.В. Перспективы и возможности микробиологической защиты растений для повышения уровня экологической безопасности в агроценозах (обзор) // Защита и карантин растений. 2022. № 4. С. 10–18. DOI: 10.47528/1026-8634\_2022\_4\_10.
9. Clare S.J., Wyatt N.A., Brueggeman R.S., Friesen T.L. Research advances in the *Pyrenophora teres* – barley interaction // Molecular Plant Pathology. 2019. N 21 (2). P. 272–288. DOI: 10.1111/mp.12896.
10. Веселова С.В., Сорокань А.В., Бурханова Г.Ф., Румянцев С.Д., Алексеев В.Ю., Черепанова Е.А., Максимов И.В. Бактерии рода *Bacillus* как перспективный источник для создания биопрепаратов от патогенов и вредителей сельскохозяйственных культур // Труды Кубанского государственного аграрного университета. 2022. № 97. С. 40–45. DOI: 10.21515/1999-1703-97-40-45.
11. Rozanova I.V., Lashina N.M., Mustafin Z.S., Gorobets S.A., Efimov V.M., Afanasenko O.S., Khlestkina E.K. SNPS associated with barley resistance to isolates of *Pyrenophora teres f. teres* // BMC Genomics. 2019. N 20 (S3). P. 292. DOI: 10.1186/s12864-019-5623-3.
12. Волкова Г.В., Данилова А.В., Яхник Я.В., Гладкова Е.В., Тарачева О.В. Иммунологическая оценка устойчивости сортов озимого ячменя к листовым болезням на юге России // Российская сельскохозяйственная наука. 2021. № 5. С. 16–21.
13. Асатурова А.М., Жевнова Н.А., Павлова М.Д., Дубяга В.М., Томашевич Н.С., Хомяк А.И., Цыгичко А.А., Бондарчук Е.Ю., Сидорова Т.М. Эффективность инокуляции семян озимой пшеницы бактериями рода *Bacillus*, перспективными для создания биопрепаратов // Зерновое хозяйство России. 2019. № 2 (62). С. 8–12.
14. Hoyer A.K., Jorgensen H.J.L., Hodkinson T.R., Jensen B. Fungal endophytes isolated from *elymus repens*, a wild relative of barley, have potential for biological control of *Fusarium culmorum* and *Pyrenophora teres* in barley // Pathogens. 2022. Vol. 11. N 10. P. 1097. DOI: 10.3390/pathogens11101097.
15. Dimkic I., Janakiev T., Petrovic M., Degrassi G., Fira D. Plant-associated *Bacillus* and *Pseudomonas* antimicrobial activities in plant disease suppression via biological control mechanisms: a review // Physiological and molecular plant pathology. 2022. N 117. P. 101754. DOI: 10.1016/j.pmp.2021.101754.
16. Ghorbanpour M., Omidvari M., Abbaszadeh-Dahaji P., Omidvar R., Kariman K. Mechanisms underlying the protective effects of beneficial

fungi against plant diseases // Biological control. 2018. N 117. P. 147–157. DOI: 10.1016/j.biocontrol.2017.11.006.

## REFERENCES

1. Mironenko N.V., Orina A.S., Kovalenko N.M. Genetic polymorphism of ToxB+ *Pyrenophora tritici-repentis* strains. *Ekologicheskaya genetika = Ecological Genetics*, 2021, vol. 19, no. 2, pp. 121–129. (In Russian). DOI: 10.17816/ecogen54718.
2. Volkova G., Yakhnik Ya. *Pyrenophora teres*: Population structure, virulence and aggressiveness in Southern Russia. *Saudi journal of biological sciences*, 2022, vol. 29, no. 10, p. 103401. DOI: 10.1016/j.sjbs.2022.103401.
3. Yakhnik Ya.V., Volkova G.V. Sensitivity of the causative agent of net blotch of barley (*Pyrenophora teres*) to a two-component fungicide based on triazole and strobilurine classes. *Izvestiya Timiryazevskoy sel'skokhozyaistvennoy akademii = Izvestiya of Timiryazev Agricultural Academy*, 2024, no. 2, pp. 127–138. (In Russian). DOI: 10.26897/0021-342X-2024-2-127-138.
4. Backes A., Guerriero G., Ait Barka E., Jacquard C. *Pyrenophora teres*: taxonomy, morphology, interaction with barley, and mode of control. *Frontiers in plant science*, 2021, no. 12, p. 614951. DOI: 10.3389/fpls.2021.614951.
5. Mironenko N.V., Lashina N.M., Baranova O.A., Zubkovich A.A., Afanasenko O.S. Hybridization between *Pyrenophora teres* forms in natural populations of Russia and the Republic of Belarus. *Mikologiya i fitopatologiya = Mycology and Phytopathology*, 2021, vol. 55, no. 1, pp. 51–58. (In Russian). DOI: 10.31857/S0026364821010074.
6. McLean M.S., Poole N., Santa I.M., Hollaway G.J. Efficacy of spot form of net blotch suppression in barley from seed, fertilizer and foliar applied fungicides. *Crop Protection*, 2022, no. 153, p. 105865. DOI: 10.1016/j.cropro.2021.105865.
7. Azizbekyan R.R. Biological preparations for the protection of agricultural plants (review). *Applied biochemistry and microbiology*, 2019, vol. 55, no. 8, pp. 816–823. DOI: 10.1134/S0003683819080027.
8. Pavlyushin V.A., Novikova I.I., Boikova I.V. Prospects and opportunities of microbiological plant protection for increasing the level of ecological safety in agricultural plant communities (review). *Zashchita i karantin rasteniy = Plant Protection and Quarantine*, 2022, no. 4, pp. 10–18. (In Russian). DOI: 10.47528/1026-8634\_2022\_4\_10.
9. Clare S.J., Wyatt N.A., Brueggeman R.S., Friesen T.L. Research advances in the *Pyrenophora teres* – barley interaction. *Molecular Plant Pathology*, 2019, no. 21 (2), pp. 272–288. DOI: 10.1111/mpp.12896.
10. Veselova S.V., Sorokan A.V., Burkhanova G.F., Rumyantsev S.D., Alekseev V.Yu., Cherepanova E.A., Maximov I.V. Bacteria of the genus *Bacillus* as a promising source for the creation of biological control agents against pathogens and pests of agricultural crops. *Trudy Kubanskogo gosudarstvennogo agrarnogo universiteta = Proceedings of the Kuban State Agrarian University*, 2022, no. 97, pp. 40–45. (In Russian). DOI: 10.21515/1999-1703-97-40-45.
11. Rozanova I.V., Lashina N.M., Mustafin Z.S., Gorobets S.A., Efimov V.M., Afanasenko O.S., Khlestkina E.K. SNPS associated with barley resistance to isolates of *Pyrenophora teres* f. *teres*. *BMC Genomics*, 2019, no. 20 (S3), p. 292. DOI: 10.1186/s12864-019-5623-3.
12. Volkova G.V., Danilova A.V., Yakhnik Ya.V., Gladkova E.V., Taracheva O.V. Immunological assessment of resistance of winter barley varieties to leaf diseases in the south of Russia. *Rossiyskaya sel'skokhoziaystvennaya nauka = Russian Agricultural Sciences*, 2021, no. 5, pp. 16–21. (In Russian).
13. Asaturova A.M., Zhevnova N.A., Pavlova M.D., Dubyaga V.M., Tomashevich N.S., Kho-myak A.I., Tsygichko A.A., Bondarchuk E.Yu., Sidorova T.M. Efficiency of winter wheat seed inoculation by the *Bacillus* bacteria promising for the development of bio medicines. *Zernovoe khozyaistvo Rossii = Grain Economy of Russia*, 2019, no. 2 (62), pp. 8–12. (In Russian).
14. Hoyer A.K., Jorgensen H.J.L., Hodkinson T.R., Jensen B. Fungal endophytes isolated from *Elymus repens*, a wild relative of barley, have potential for biological control of *Fusarium culmorum* and *Pyrenophora teres* in barley. *Pathogens*, 2022, vol. 11, no. 10, p. 1097. DOI: 10.3390/pathogens11101097.
15. Dimkic I., Janakiev T., Petrovic M., Degrassi G., Fira D. Plant-associated *Bacillus* and *Pseudomonas* antimicrobial activities in plant disease suppression via biological control mechanisms: a review. *Physiological and molecular plant pathology*, 2022, no. 117, p. 101754. DOI: 10.1016/j.pmp.2021.101754.
16. Ghorbanpour M., Omidvari M., Abbaszadeh-Dahaji P., Omidvar R., Kariman K. Mechanisms underlying the protective effects of beneficial fungi against plant diseases. *Biological control*, 2018, no. 117, pp. 147–157. DOI: 10.1016/j.biocontrol.2017.11.006.

## ИНФОРМАЦИЯ ОБ АВТОРАХ

**Асатурова А.М.**, кандидат биологических наук, ведущий научный сотрудник, директор

✉ **Жевнова Н.А.**, кандидат биологических наук, старший научный сотрудник; **адрес для переписки:** Россия, 350039, Краснодар, п/о 39; e-mail: n.zhevnova@mail.ru

**Сидоров Н.М.**, научный сотрудник

**Кремнева О.Ю.**, кандидат биологических наук, ведущий научный сотрудник

## AUTHOR INFORMATION

**Anzhela M. Asaturova**, Candidate of Science in Biology, Lead Researcher, Director

✉ **Natalya A. Zhevnova**, Candidate of Science in Biology, Senior Researcher; **address:** PO Box 39, Krasnodar, 350039, Russia; e-mail: n.zhevnova@mail.ru

**Nikita M. Sidorov**, Researcher

**Oksana Yu. Kremneva**, Candidate of Science in Biology, Lead Researcher

*Дата поступления статьи / Received by the editors 02.08.2024*

*Дата принятия к публикации / Accepted for publication 12.09.2024*

*Дата публикации / Published 20.11.2024*



## Мониторинг коагулазоотрицательных стафилококков, выделенных из сборного молока в неблагополучных по маститу коров хозяйствах

Попов П.А., ✉ Осипова И.С.

Всероссийский научно-исследовательский институт ветеринарной санитарии, гигиены и экологии – филиал Федерального научного центра «Всероссийский научно-исследовательский институт экспериментальной ветеринарии им. К.И. Скрябина и Я.Р. Коваленко Российской академии наук»  
Москва, Россия

✉ e-mail: irishka21062801@mail.ru

Одним из важных аспектов, гарантирующих безопасность продукции, является постоянный санитарно-микробиологический контроль на всех этапах производства. В данном исследовании приведен анализ мониторинговых исследований, направленных на определение спектра распространенных видов коагулазоотрицательных стафилококков в сборном молоке в течение года на четырех молочно-товарных фермах Московской области, неблагополучных по маститам. Выяснено, что *Staphylococcus epidermidis* выявляли чаще других видов (42,9% от числа выделенных коагулазоотрицательных стафилококков), реже обнаруживали *St. saprophyticus* и *St. simulans* (по 14,3%), еще реже регистрировали *St. haemolyticus*, *St. chromogenes*, *St. lentus* и *St. hominis* (по 7,1%). Установлено, что осенью во всех хозяйствах в сборном молоке выделяли до 28,0% бактерий из рода *Staphylococcus*. Приведено соотношение *St. aureus* и коагулазоотрицательных стафилококков в сборном молоке на фермах Московской области в осенний период. Проведена идентификация коагулазонегативных стафилококков, выделенных в осенний период лактации. В сборном молоке чаще выявляли *St. saprophyticus* и *St. epidermidis* (по 23,1%), в 15,4% случаев регистрировали *St. simulans* и *St. chromogenes*, несколько реже *St. hominis*, *St. haemolyticus*, *St. lentus* (по 7,7%). Дан анализ средних данных по индикации стафилококков, полученных за 2023 г. в различных хозяйствах Московской области из сборного молока. Уровень стафилококков в сборном молоке в весенний период был наиболее высоким (38,1%), летом и осенью данные были приблизительно одинаковыми (25,3–28,0%). Самый низкий уровень стафилококков в сборном молоке наблюдали зимой (18,5%).

**Ключевые слова:** молоко, маститы, коагулазоотрицательные стафилококки, токсикоинфекции, эпизоотологическое значение

## Monitoring of coagulase-negative staphylococci isolated from the bulk milk in the farms troubled by cow mastitis

Popov P.A., ✉ Osipova I.S.

All-Russian Scientific Research Institute of Veterinary Sanitation, Hygiene and Ecology – Branch of the Federal Scientific Center “All-Russian Scientific Research Institute of Experimental Veterinary Medicine named after K.I. Scriabin and Ya.R. Kovalenko” of the Russian Academy of Sciences  
Moscow, Russia

✉ e-mail: irishka21062801@mail.ru

One of the important aspects that guarantee product safety is constant sanitary and microbiological control at all stages of production. This study presents an analysis of monitoring investigations aimed at determining the spectrum of common species of coagulase-negative staphylococci in the bulk milk at four mastitis-unfavorable dairy farms in the Moscow region during one year. It was found that

*Staphylococcus epidermidis* was detected more frequently than other species (42.9% of the number of the isolated coagulase-negative staphylococci), *St. saprophyticus* and *St. simulans* were detected less frequently (14.3% each), *St. haemolyticus*, *St. chromogenes*, *St. lentus* and *St. hominis* were registered even less frequently (7.1% each). It was determined that up to 28.0% of bacteria of the genus *Staphylococcus* were isolated in the bulk milk in autumn on all the farms. The ratio of *St. aureus* and coagulase-negative staphylococci in the bulk milk on the farms of the Moscow region in the autumn period is presented. Identification of coagulase-negative staphylococci isolated during the autumn lactation period has been performed. In the bulk milk, *St. saprophyticus* and *St. epidermidis* were detected more frequently (23.1% each), *St. simulans* and *St. chromogenes* were detected in 15.4% of the cases, and *St. hominis*, *St. haemolyticus*, and *St. lentus* were detected somewhat less frequently (7.7% each). Average data on *Staphylococcus aureus* indication obtained for 2023 in different farms of the Moscow region from the bulk milk have been analyzed. Staphylococci levels in the bulk milk were highest in spring (38.1%), summer and autumn data were approximately the same (25.3–28.0%). The lowest level of staphylococci in the bulk milk was observed in winter (18.5%).

**Keywords:** milk, mastitis, coagulase-negative staphylococci, toxic infections, epizootologic significance

**Для цитирования:** Попов П.А., Осипова И.С. Мониторинг коагулазоотрицательных стафилококков, выделенных из сборного молока в неблагополучных по маститу коров хозяйствах // Сибирский вестник сельскохозяйственной науки. 2024. Т. 54. № 10. С. 78–84. <https://doi.org/10.26898/0370-8799-2024-10-8>

**For citation:** Popov P.A., Osipova I.S. Monitoring of coagulase-negative staphylococci isolated from the bulk milk in the farms troubled by cow mastitis. *Sibirskii vestnik sel'skokhozyaistvennoi nauki* = *Siberian Herald of Agricultural Science*, 2024, vol. 54, no. 10, pp. 78–84. <https://doi.org/10.26898/0370-8799-2024-10-8>

**Конфликт интересов**

Авторы заявляют об отсутствии конфликта интересов.

**Conflict of interest**

The authors declare no conflict of interest.

## INTRODUCTION

Milk is a unique natural food product that must meet sanitary and hygienic standards. Its high content of nutrients, primarily proteins, makes milk an almost universal medium for most types of microflora, including pathogenic and technologically harmful bacteria. In the context of a market economy and the development of agriculture and farming, it is important to ensure the improvement of sanitary and microbiological indicators of milk. Only milk that meets the requirements not only for nutritional value and organoleptic properties but also for safety of consumption can be considered high-quality. [1, 2].

The quality of milk often declines due to high microbial contamination, which is why many researchers agree that immediately after milking a healthy animal, milk contains only a small number of microorganisms. However, secondary microbial contamination occurs immediately after milking at all stages of production and processing [3–5].

One of the important ways to significantly improve the quality and safety of dairy products on the Russian market is the use of highly effective methods of sanitary and microbiological control.

The bacteriological method, which is used in the diagnosis of most modern infections, has always been considered as the most reliable and effective way to identify pathogens. The essence of the method is the isolation of pure culture of microorganism, then its determination by characteristic features: biochemical, tinctorial, antigenic and so on. However, the disadvantage of this method is the impossibility of rapid analysis [6, 7].

To accelerate the process of identification of the isolated microorganism culture, special differentiating substrates and appropriate indicators are usually used [8, 9].

The number of microbial colonies can be quickly counted using a variety of automated laser devices, as well as with the use of liquid

cytometry, a method that allows counting each individual cell. Methods and instruments that utilize a piezoelectric crystal sensor with a split electrode have been developed for rapid detection of bacteria [10, 11]. In addition, accelerated methods of detection of pathogen antigens are widely used both in biological objects and in environmental objects. Among such methods the following can be distinguished: immunoenzyme method, fluorescent antibody method, coagglutination reaction, immunodiffusion reaction in agar, and passive hemagglutination inhibition reaction. These methods provide a standardized way to perform bacteriological tests to determine the presence of microorganisms [12–16].

The purpose of the work is to conduct monitoring studies aimed at determining the spectrum of common species of coagulase-negative staphylococci in the collected milk at the dairy farms of the Moscow region over the course of a year.

## MATERIAL AND METHODS

The work was carried out in the laboratory of veterinary and sanitary expertise VNIIVSGE - branch of the All-Russian Research Institute of Experimental Veterinary Medicine. The experimental-laboratory method was used in the work.

In 2021 in the Moscow region veterinary specialists conducted more than 760 thousand tests of cows for mastitis, more than 34 thousand cases of the disease were detected [1].

In our study, raw milk samples were collected from mastitis-endangered dairy farms in the Moscow region. Then these samples were prepared for research in accordance with GOST 26809.1-2014 “Milk and dairy products. Acceptance rules, methods of selection and preparation of samples for analysis”. 217 samples of raw collected milk were analyzed.

The isolation of staphylococci from raw milk and determination of their plasmocoagulating ability were carried out according to the “Methodological guidelines for bacteriological examination of milk and udder secretion of cows” (1983) and GOST 30347-2016 Milk and dairy products. “Methods of determination of *Staphylococcus aureus*”. Staphylococcus species were isolated only in monocultures.

## RESULTS AND DISCUSSION

Conducting microbiological monitoring allows to determine more accurately the level of sanitary-indicative microflora in raw milk and take timely sanitary measures to ensure product safety. Special attention should be paid to the staphylococci genus, which are frequent causative agents of cow mastitis and contaminate raw milk and milk products. There are enterotoxigenic strains among staphylococci that can cause severe toxicosis in humans.

When identifying coagulase-negative strains of staphylococci in collected milk on the farms of Moscow region, it was found that *Staphylococcus epidermidis* was detected more often than other species (42.9% of the number of the isolated coagulase-negative staphylococci), less frequently detected were *St. saprophyticus* and *St. simulans* (14,3% each). Even rarer were the registrations of *St. haemolyticus*, *St. chromogenes*, *St. lentus* and *St. hominis* (7,1% each) (see fig. 1).

Data on the detection of staphylococci depending on the farm in the autumn period of lactation are presented in fig. 2. It was revealed that in the autumn, up to 28% of bacteria of the genus *Staphylococcus aureus* were isolated in the collected milk in all farms.

*St. aureus* was isolated in 43.5% of cases, coagulase-negative staphylococci were registered in 56.5% of cases from the collected milk on the farms of the Moscow region during the autumn lactation period. As for farms specifically, only in farm 4 coagulase-negative staphylococci were detected in 100% of samples. On other farms, the ratio of coagulase-positive and coagulase-negative staphylococci was 1 : 1 or 1 : 2 (see fig. 3).

Further we identified coagulase-negative staphylococci isolated in the autumn period of lactation. *St. saprophyticus* and *St. epidermidis* (23.1% each) were detected more frequently in the collected milk, *St. simulans* and *St. chromogenes* were registered in 15.4% of cases, *St. hominis*, *St. haemolyticus*, and *St. lentus* were detected somewhat less frequently (7.7% each) (see fig. 4).

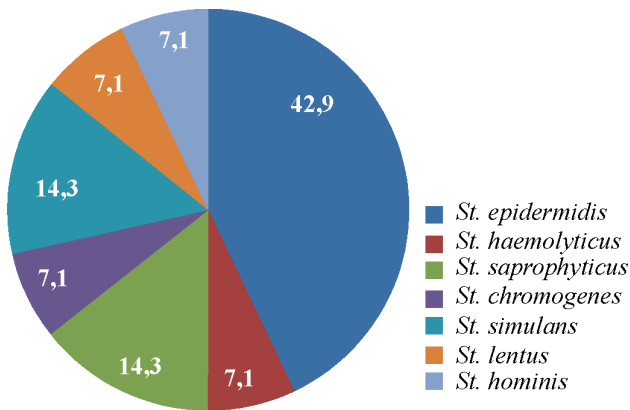

**Рис. 1.** Видовая идентификация коагулазоотрицательных стафилококков, выделенных из сборного молока в летний период, %

**Fig. 1.** Species identification of coagulase-negative staphylococci isolated from the bulk milk in the summer period, %

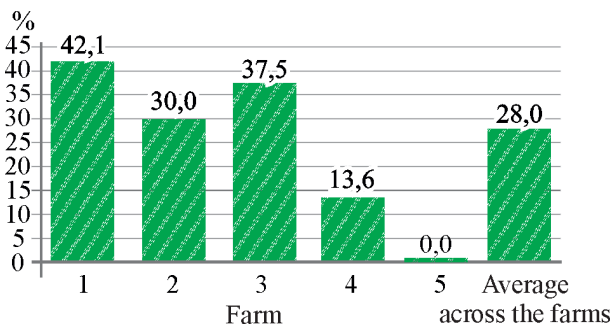

**Рис. 2.** Выявление стафилококков в сборном молоке в различных хозяйствах

Московской области в осенний период, %

**Fig. 2.** Detection of staphylococci in different farms of the Moscow region in the autumn period, %

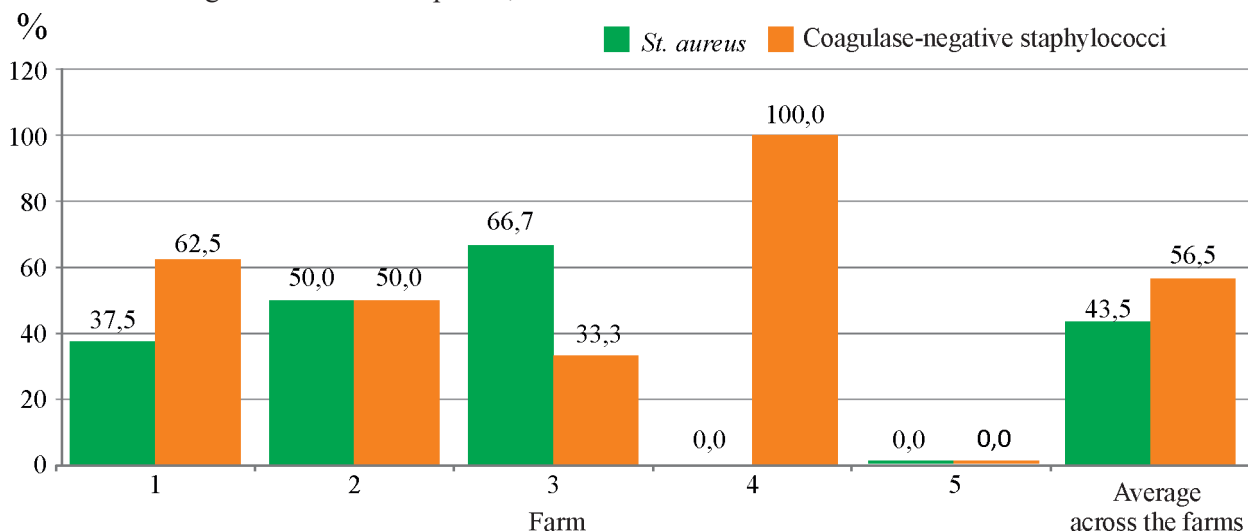

**Рис. 3.** Соотношение *St. aureus* и коагулазоотрицательных стафилококков в сборном молоке на фермах Московской области в осенний период, %

**Fig. 3.** Ratio of *St. aureus* and coagulase-negative staphylococci in the bulk milk in the farms of the Moscow region in the autumn period, %

The average data on the indication of staphylococci obtained for 2023 in different farms of the Moscow region from collected milk were also analyzed. The level of staphylococci in the collected milk was the highest in spring (38.1%), in summer and autumn the data were approximately the same (25.3-28.0%). The lowest level of staphylococci in the collected milk was observed in winter (18.5%) (see fig. 5).

## CONCLUSION

In 2023, the monitoring of coagulase-negative staphylococcus species isolated from samples of the collected milk from four mastitis-affected dairy farms of the Moscow region was carried out. It is necessary to emphasize the study of coagulase-negative enterotoxigenic staphylococci in fresh milk, as their timely detection will prevent the occurrence of toxic infections and milk toxicosis.

## СПИСОК ЛИТЕРАТУРЫ

1. Попов П.А. Микробиологический состав молока и пути его контаминации // Политематический сетевой электронный научный журнал Кубанского государственного аграрного университета. 2021. № 168. С. 208–216.
2. Безбородов Н.В., Зуев Н.П., Зуева Е.Е. Совершенствование методов лечения коров с острым гнойно-катаральным маститом //

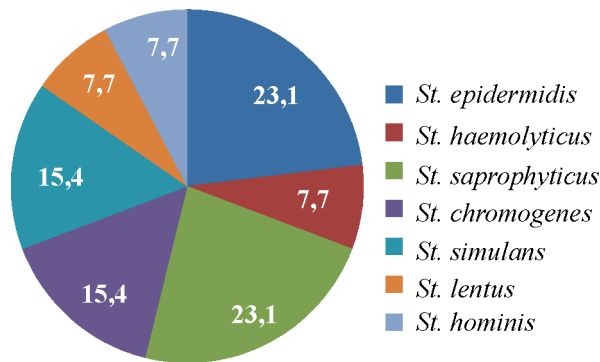

**Рис. 4.** Видовая идентификация коагулазоотрицательных стафилококков, выделенных из сборного молока в осенний период, %

**Fig. 4.** Species identification of coagulase-negative staphylococci isolated from the bulk milk in the autumn period, %

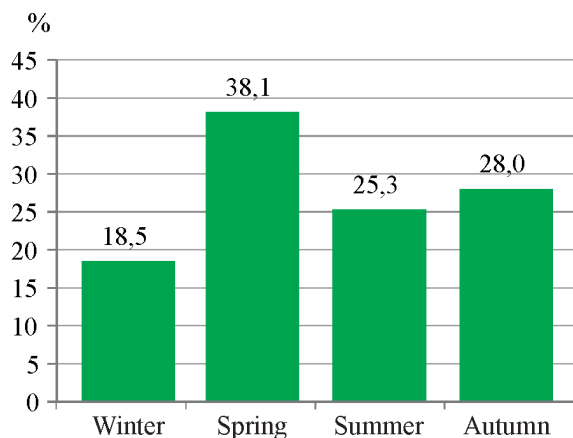

**Рис. 5.** Результаты мониторинговых исследований по индикации стафилококков в сыром молоке за 2023 г. в хозяйствах Московской области в зависимости от сезонов года, %

**Fig. 5.** Results of monitoring investigations on staphylococci indication in raw milk for 2023 in the farms of the Moscow region depending on the seasons of the year, %

Актуальные вопросы сельскохозяйственной биологии. 2020. № 4 (18). С. 79–88.

3. Коваленко А.В., Кононенко К.Н., Фетищев Л.Н., Зубенко А.А., Клименко А.И., Бодряков А.Н. Разработка новых химиопрепаратов для лечения коров при маститах // Ветеринария и кормление. 2020. № 6. С. 26–28. DOI: 10.30917/АГТ-ВК-1814-9588-2020-6-7.
4. Семиволос А.М., Лощинин С.О., Агольцов В.А., Семиволос С.А., Падило Л.П. Оценка эффективности мастит-тестов для диагностики субклинического мастита у коров // Аграрный научный журнал. 2024. № 2.

С. 79–82. DOI: 10.28983/asj.y2024i2pp79-82.

5. Коба И.С., Степанишин В.В., Новикова Е.Н., Скориков А.В. Особенности формирования антимикробной резистентности микроорганизмов на животноводческих комплексах при маститах у коров // Ветеринария, зоотехния и биотехнология. 2021. № 10. С. 55–62. DOI: 10.36871/vet.zoo.bio.202110008.
6. Джавадов Э.Д., Стекольников А.А., Ладанова М.А., Новикова О.Б. Спектр микрофлоры, выделяемой при мастите коров // Вопросы нормативно-правового регулирования в ветеринарии. 2020. № 4. С. 66–68. DOI: 10.17238/issn2072-6023.2020.4.66.
7. Зуев Н.П., Тучков Н.С. Лечение лактирующих коров с субклиническим маститом // Эффективное животноводство. 2023. № 5 (187). С. 46–48.
8. Мяленко Д.М., Федотова О.Б., Рязанцева К.А., Шерстнева Н.Е., Агаркова Е.Ю. Ультрафиолет. Теория и практика применения в молочной промышленности: монография. М., 2023. 120 с. DOI: 10.37442/978-5-6049465-4-1.
9. Маневич Б.В., Бурыкина Е.А. Об особенностях использования пероксида водорода на молочных предприятиях // Молочная промышленность. 2023. № 5. С. 108–110. DOI: 10.21603/1019-8946-2023-5-10.
10. Хан А.В., Лазарева Е.Г., Фоменко О.Ю. Проблема фальсификации молочных продуктов: анализ состояния и пути решения // Молочная промышленность. 2023. № 5. С. 54–56. DOI: 10.21603/1019-8946-2023-5-6.
11. Маневич Б.В. Аспекты регламентирования процессов и средств при проведении санитарно-противоэпидемических мероприятий // Сыроделие и маслоделие. 2023. № 4. С. 89–91.
12. Шурдуба Н.А., Грузнов Д.В., Токарев С.В. Метод АТФ-билюминесценции для оперативного контроля качества санации сосковой резины доильных аппаратов // Проблемы ветеринарной санитарии, гигиены и экологии. 2019. № 4 (32). С. 434–440. DOI: 10.36871/vet.san.hyг.ecol.201904015.
13. Шурдуба Н.А., Грузнов Д.В. Стафилококковые биопленки: новый вызов для санитарии молочной и мясной перерабатывающей промышленности // Проблемы ветеринарной санитарии, гигиены и экологии. 2019.

- № 3 (31). С. 302–306. DOI: 10.25725/vet.san.hyг.ecol.201903010.
14. Сотникова В.М., Шурдуба Н.А., Грузнов Д.В. Взаимосвязь между количеством бактериальной АТФ и числом клеток микроорганизмов в смывах чистых и смешанных культур эшерихий и золотистого стафилококка // Проблемы ветеринарной санитарии, гигиены и экологии. 2019. № 2 (26). С. 74–78. DOI: 10.36871/vet.san.hyг.ecol.201802013.
  15. Сотникова В.М., Шурдуба Н.А., Грузнов Д.В., Токарев С.В. Взаимосвязь суммарной, свободной и бактериальной АТФ в сыром молоке от здоровых коров // Проблемы ветеринарной санитарии, гигиены и экологии. 2019. № 4 (28). С. 50–55. DOI: 10.25725/vet.san.hyг.ecol.201804008.
  16. Aliyev A.Yu., Karpuschenko K.A. An alternative remedy for the treatment of mastitis in cows // Agrarian Science. 2023. N 10. P. 30–33.
- ## REFERENCES
1. Popov P.A. Microbiological composition of milk and ways of its contamination. *Politechnicheskii setevoi elektronnyi nauchnyi zhurnal Kubanskogo gosudarstvennogo agrarnogo universiteta = Polythematic online scientific journal of Kuban State Agrarian University*, 2021, no. 168, pp. 208–216. (In Russian).
  2. Bezborodov N.V., Zuev N.P., Zueva E.E. Improving the treatment of cows with acute purulent-catarrhal mastitis. *Aktual'nye voprosy sel'skokhozyaistvennoi biologii = Actual issues in agricultural biology*, 2020, no. 4 (18), pp. 79–88. (In Russian).
  3. Kovalenko A.V., Kononenko K.N., Fetisov L.N., Zubenko A.A., Klimenko A.I., Bodryakov A.N. Development of new chemopreparations for treatment of cows with mastitis. *Veterinariya i kormlenie = Veterinaria i kormlenie*, 2020, no. 6, pp. 26–28. (In Russian). DOI: 10.30917/ATT-VK-1814-9588-2020-6-7.
  4. Semivolos A.M., Loshinin S.O., Agoltsov V.A., Semivolos S.A., Padilo L.P. Evaluation of the effectiveness of mastitis tests for the diagnosis of subclinical mastitis in cows. *Agrarnyi nauchnyi zhurnal = Agrarian Scientific Journal*, 2024, no. 2, pp. 79–82. (In Russian). DOI: 10.28983/asj.y2024i2pp79-82.
  5. Koba I.S., Stepanishin V.V., Novikova E.N., Skorikov A.V. Features of microorganism resistance formation on livestock complexes during mastitis in cows. *Veterinariya, zootekhnika i biotekhnologiya = Veterinary Medicine, Zootechnics and Biotechnology*, 2021, no. 10, pp. 55–62. (In Russian). DOI: 10.36871/vet.zoo.bio.202110008.
  6. Javadov E.D., Stekolnikov A.A., Ladanova M.A., Novikova O.B. Spectrum of microflora released during mastitis in cows. *Voprosy normativno-pravovogo regulirovaniya v veterinarii = Legal regulation in veterinary medicine*, 2020, no. 4, pp. 66–68. (In Russian). DOI: 10.17238/issn2072-6023.2020.4.66.
  7. Zuev N.P., Tuchkov N.S. Treatment of lactating cows with subclinical mastitis. *Effektivnoe zhivotnovodstvo = Effective Animal Husbandry*, 2023, no. 5 (187), pp. 46–48. (In Russian).
  8. Myalenko D.M., Fedotova O.B., Ryazantseva K.A., Sherstneva N.E., Agarkova E.Yu. *Ultraviolet. Theory and practice of application in the dairy industry*. Moscow, 2023, 120 p. (In Russian). DOI: 10.37442/978-5-6049465-4-1.
  9. Manevich B.V., Burykina E.A. Peculiarities of hydrogen peroxide use in dairy enterprises. *Molochnaya promyshlennost' = Dairy Industry*, 2023, no. 5, pp. 108–110. (In Russian). DOI: 10.21603/1019-8946-2023-5-10.
  10. Khan A.V., Lazareva E.G., Fomenko O.Yu. The problem of dairy products adulteration: analysis of the state and ways of resolution. *Molochnaya promyshlennost' = Dairy Industry*, 2023, no. 5, pp. 54–56. (In Russian). DOI: 10.21603/1019-8946-2023-5-6.
  11. Manevich B.V. Sanitary and epidemic control measures: regulating processes and means. *Syrodellie i maslodellie = Cheesemaking and buttermaking*, 2023, no. 4, pp. 89–91. (In Russian).
  12. Shurduba N.A., Gruznov D.V., Tokarev S.V. ATP bioluminescence method for operational quality control of sanitation of nipple rubber of milking machines. *Problemy veterinarnoi sanitarii, gigieny i ekologii = Problems of Veterinary Sanitation, Hygiene and Ecology*, 2019, no. 4 (32), pp. 434–440. (In Russian). DOI: 10.36871/vet.san.hyг.ecol.201904015.
  13. Shurduba N.A., Gruznov D.V. Staphylococcal biofilms: a new challenge for the sanitation of the dairy and meat processing industry. *Problemy veterinarnoi sanitarii, gigieny i ekologii = Problems of Veterinary Sanitation, Hygiene and Ecology*, 2019, no. 3 (31), pp. 302–306. (In Russian). DOI: 10.25725/vet.san.hyг.ecol.201903010.

14. Sotnikova V.M., Shurduba N.A., Gruznov D.V. Relationship between the number of bacterial ATP and the number of micro-organism cells in the waste of pure and mixed cultures of *Escherichia* and *Staphylococcus aureus*. *Problemy veterinarnoi sanitarii, gigienny i ekologii = Problems of Veterinary Sanitation, Hygiene and Ecology*, 2019, no. 2 (26), pp. 74–78 (In Russian). DOI: 10.36871/vet.san.hyг.ecol.201802013.
15. Sotnikova V.M., Shurduba N.A., Gruznov D.V., Tokarev S.V. Relationship of total, free and bacterial ATP in raw milk from healthy cows. *Problemy veterinarnoi sanitarii, gigienny i ekologii = Problems of Veterinary Sanitation, Hygiene and Ecology*, 2019, no. 4 (28), pp. 50–55. (In Russian). DOI: 10.25725/vet.san.hyг.ecol.201804008.
16. Aliev A.Yu., Karpushchenko K.A. An alternative remedy for the treatment of mastitis in cows. *Agrarian science*, 2023, no. 10, pp. 30–33.

#### ИНФОРМАЦИЯ ОБ АВТОРАХ

**Попов П.А.**, доктор ветеринарных наук, руководитель института

✉ **Осипова И.С.**, кандидат ветеринарных наук, ведущий научный сотрудник; **адрес для переписки:** Россия, 123022, Москва, Звенигородское шоссе, д. 5; e-mail: irishka21062801@mail.ru

#### AUTHOR INFORMATION

**Petr A. Popov**, Doctor of Science in Veterinary Medicine, Head of the Institute

✉ **Irina S. Osipova**, Candidate of Science in Veterinary Medicine, Lead Researcher; **address:** 5, Zvenigorodskoe shosse, Moscow, 123022, Russia; e-mail: irishka21062801@mail.ru

Дата поступления статьи / Received by the editors 08.04.2024  
Дата принятия к публикации / Accepted for publication 25.06.2024  
Дата публикации / Published 20.11.2024

## Эпизоотическая ситуация по лейкозу крупного рогатого скота в Омской области и краткосрочный прогноз ее развития

Власенко В.С., Борисов Е.С., (✉)Новикова Н.Н.

*Омский аграрный научный центр*

Омск, Россия

(✉)e-mail: Novikova@anc55.ru

На основании полученных сведений о результатах диагностических исследований в реакции иммунной диффузии (РИД) и гематологическим методом осуществлен анализ эпизоотической ситуации по лейкозу крупного рогатого скота в Омской области с 2018 по 2022 г. Несмотря на повсеместное распространение вирусной инфекции, отмечена тенденция к некоторому снижению числа положительных проб от 16,8% в 2018 г. до 14% в 2022 г., тем не менее, уровень серопревалентности на преобладающей части области превысил 5%. Процент больных лейкозом животных в этот период, напротив, увеличился в 1,5 раза. С целью прогнозирования дальнейшего развития эпизоотической ситуации по лейкозу крупного рогатого скота на следующем этапе исследований создано несколько модификаций искусственных нейронных сетей (ИНС) с нелинейной зависимостью от чисел Вольфа ( $W$ ), гармоник спектральной модели Фурье, а также дополнительно введенного фактора «Сигма», принимающего значение 1 при  $W \geq 110$  на входе. Использованы три подхода исследования ИНС: с проведением спектрального анализа от начала известного периода (с 1994 г.); с проведением спектрального анализа с конца известного периода (с 2022 г.); с построением ИНС с первого по девятый слой с нарастанием по нечетной схеме. В общей сложности создано 9 пакетов, включающих свыше 40 нейронных сетей. Исследования проведены по направлению увеличения числа слоев нейронной сети и изменения состава гармоник. В некоторых ИНС при наращивании количества слоев отмечен значительный разброс ожидаемого числа случаев инфицирования вирусом лейкоза крупного рогатого скота. В других, наоборот, разброс прогноза был минимальным. Применение указанных подходов дает возможность рассматривать различные сценарии развития эпизоотической ситуации по лейкозу крупного рогатого скота и осуществить выбор наиболее оптимальных моделей при поступлении новых данных о распространении инфекции.

**Ключевые слова:** лейкоз, крупный рогатый скот, прогноз, искусственные нейронные сети, спектральный анализ Фурье

## Epizootic situation on bovine leukosis in the Omsk region and a short-term forecast of its development

Vlasenko V.S., Borisov E.S., (✉)Novikova N.N.

*Omsk Agrarian Scientific Center*

Omsk, Russia

(✉)e-mail: Novikova@anc55.ru

The analysis of the epizootic situation on bovine leukosis in the Omsk region from 2018 to 2022 was carried out on the basis of the received data on the results of diagnostic tests in the immune diffusion reaction (IDR) and the hematological method. Despite the widespread viral infection, there was a slight downward trend in the number of positive samples from 16.8% in 2018 to 14% in 2022, nevertheless, the seroprevalence rate exceeded 5% in the predominant part of the region. The percentage of animals with leukosis during this period, on the contrary, increased 1.5 times. Several modifications of artificial neural networks (ANN) with nonlinear dependence on the Wolf numbers ( $W$ ), harmonics of the Fourier spectral model, as well as the additionally introduced factor “Sigma”, which takes the value of 1 at  $W \geq 110$  at the input, were created at the next stage of the research in order to predict the further development of the epizootic situation in bovine leukosis. Three approaches of the ANN research were used: with spectral analysis from the beginning of the known period (from 1994); with spectral analysis from the end of the known period (from 2022); with construction of the ANN from the 1st to the 9th layers with odd-numbered acceleration. A total of 9 packages including more than 40

neural networks were created. The research was carried out in the direction of increasing the number of layers of the neural network and changing the harmonic composition. In some ANNs, a significant variation in the expected number of bovine leukosis virus infections was observed when the number of the layers was increased. In others, on the contrary, the forecast spread was minimal. Application of these approaches makes it possible to consider different scenarios of epizootic situation development in bovine leukosis and to choose the most optimal models when new data on the spread of infection become available.

**Keywords:** leukosis, cattle, forecast, artificial neural networks, Fourier spectral analysis

**Для цитирования:** Власенко В.С., Борисов Е.С., Новикова Н.Н. Эпизоотическая ситуация по лейкозу крупного рогатого скота в Омской области и краткосрочный прогноз ее развития // Сибирский вестник сельскохозяйственной науки. 2024. Т. 54. № 10. С. 85–92. <https://doi.org/10.26898/0370-8799-2024-10-9>

**For citation:** Vlasenko V.S., Borisov E.S., Novikova N.N. Epizootic situation on bovine leukosis in the Omsk region and a short-term forecast of its development. *Sibirskii vestnik sel'skokhozyaistvennoi nauki = Siberian Herald of Agricultural Science*, 2024, vol. 54, no. 10, pp. 85–92. <https://doi.org/10.26898/0370-8799-2024-10-9>

**Конфликт интересов**

Авторы заявляют об отсутствии конфликта интересов.

**Conflict of interest**

The authors declare no conflict of interest.

## INTRODUCTION

The bovine leukemia virus (BLV), the etiological agent of enzootic bovine leukosis, has been eradicated in most European Union countries, while in other states, including some regions of the Russian Federation, there has been an increase in the spread of this infection, especially among dairy cattle. Like other retroviruses, this pathogen induces various disruptions in the immune system, affecting both cellular and humoral immunity, which, in turn, play a significant role in reducing milk productivity and shortening the productive lifespan [1–5].

To organize effective measures for the prevention and control of BLV, as well as to objectively predict future scenarios of the infection's development, it is extremely important to study the patterns and characteristics of the spread and manifestation of the epizootic over a long-term period using various mathematical modeling methods [6–10]. For the analysis of time series and the prediction of their further development, various statistical techniques are usually applied. However, methods based on artificial intelligence are capable of evaluating such data with better predictive capabilities compared to statistical methods [11–13].

In our previous study [14], two algorithms for modeling future scenarios were applied to predict the number of cases of BLV infection in animals in the Omsk region: Fourier spectral analysis and artificial neural networks (ANN). In our opinion, these models require further improvement.

The purpose of the research is to study the epizootic situation on bovine leukosis in the Omsk region and to make a forecast of the development of the infection on the basis of the obtained data using different modifications of ANN.

## MATERIAL AND METHODS

The data of veterinary reports of the Main Veterinary Department and documentation of district veterinary laboratories on the number of animals serologically tested in the immune diffusion reaction (IDR), the number of virus-carrying animals (as a percentage) from 1994 to 2022, as well as on the results of hematologic studies of cattle for the last 5 years were used in the work (2018–2022).

The mapping of BLV infection was performed using a special computer program.

Data on solar activity, expressed as annual averages of Wolf numbers  $W$  (relative number

of sunspots), from 1994 to 2022 are taken from the server Solar Influences Data Analysis Center<sup>1</sup>.

Artificial neural networks were created using the program NeuroPro, version 0.25 (developer V.G. Tsaregorodtsev, Institute of Computational Modeling, Siberian Branch of the Russian Academy of Sciences, Krasnoyarsk).

## RESULTS AND DISCUSSION

From 2018 to 2022, more than 1 832 000 animal serum samples were serologically tested by immune diffusion reaction (IDR), of which about 287 000 were positive, or 15.7% (see Table 1). During this time period, the highest percentage of virus carriers was recorded in 2020 (17.6%), but in subsequent years a decrease in the number of positive samples was noted, reaching a minimum in 2022 (14.0%).

During the analyzed period, over 716 thousand blood samples were also examined using the hematological method, which allowed identifying 1 934 (0.27%) animals with leukosis. The minimum number of animals with leukosis was identified in 2019– 0.19%, the maximum in 2022 –0.37%.

The cartogram of leukosis infection spreading in the Omsk region according to the results of diagnostic tests in 2022, compiled by us at the

next stage, clearly demonstrated the ubiquitous spread of BLV (see the figure).

According to the presented cartogram, the level of BLV carriage in the vast majority of the administrative and territorial units is over 5%, only in the Azovsky, Krutinsky, Novovarshevsky, Odesky, Okoneshnikovsky and Sedelnikovsky districts it was 5% and lower.

The most difficult epizootic situation on bovine leukosis has developed in the Isilkulsky, Moskalensky, Gorkovsky, Tarsky, Sargatsky and Lyubinsky districts, where diagnostic tests of blood sera revealed more than 26% of positive samples.

Hematological studies showed that the maximum number of animals with leukosis in 2022 was registered in the Pavlogradsky – 285 (8.5%), Maryanovsky – 62 (2.7), Lyubinsky – 52 (0.9) and Moskalensky – 48 (0.3%) districts of the Omsk region.

At the final stage of research for predicting possible scenarios of epizootic situation development on bovine leukosis in 2023, the work on studying of our previously compiled predictive models with the help of spectral analysis and ANN was continued [14].

For this purpose, several resulting modifications of ANN were created, the scheme of construction of which basically remained the same.

**Табл. 1.** Сведения о диагностических исследованиях по лейкозу крупного рогатого скота в Омской области

**Table 1.** Information on diagnostic studies for bovine leukosis in the Omsk region

Studies	Year					Total for 5 years
	2018	2019	2020	2021	2022	
Serologic:						
total	384 236	381 211	365 455	352 197	349 363	1 832 462
RID +	64 615	55 085	64 198	54 790	48 947	287 635
percentage	16,8	14,5	17,6	15,6	14,0	15,7
Hematologic:						
total	147 657	149 890	150 668	144 231	124 317	716 763
sick	373	291	398	406	466	1934
percentage	0,25	0,19	0,26	0,28	0,37	0,27

<sup>1</sup>World Data Center for the production, preservation and dissemination of the international sunspot number // Royal Observatory of Belgium (Brussels, Belgium). <http://www.sidc.be/silso/datafiles>

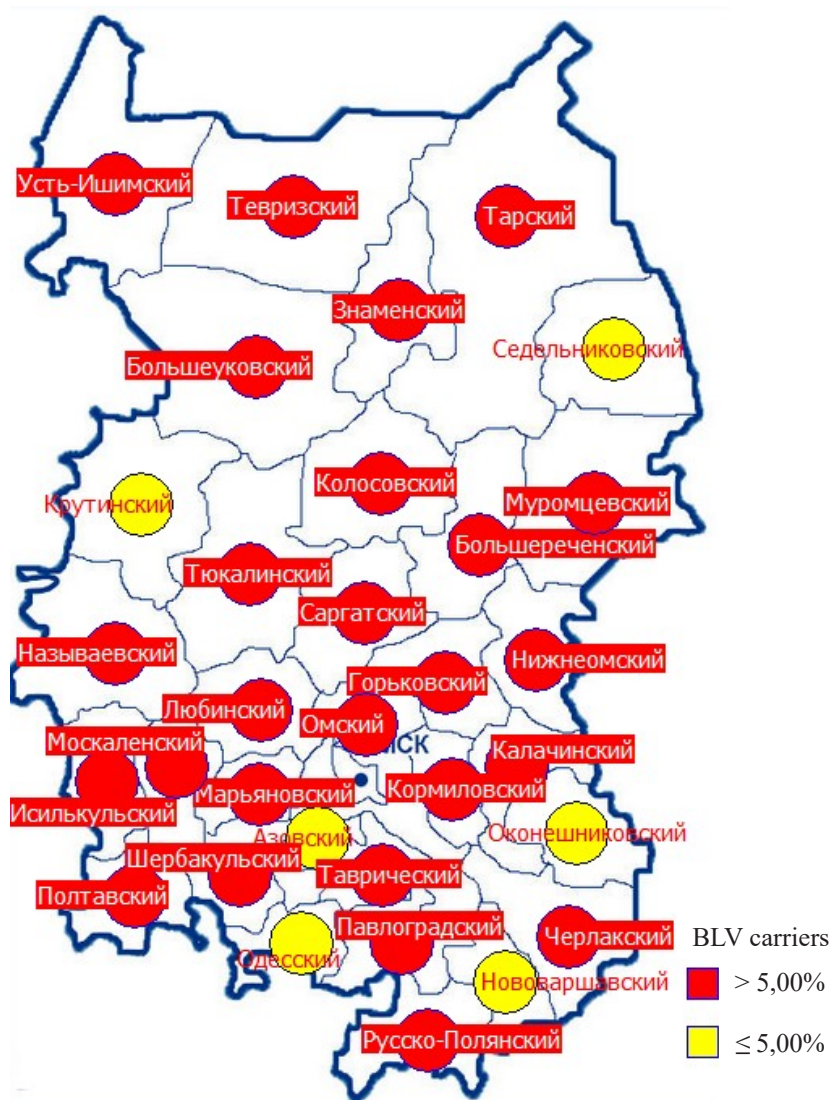

Картограмма инфицированности ВЛКРС за 2022 г.  
Cartogram of the BLV infection rates for 2022

As before, the input factors were Wolf numbers with a shift of one year, a combination of harmonics obtained as a result of spectral analysis of the trend of BLV infection in the Omsk region for 23 years. Unlike the previous neural network, a qualitative factor is introduced under the conditional name “Sigma”. This factor works as a trigger and takes the value 1 in case of exceeding the threshold of Wolf numbers 110, otherwise it is equal to 0. In addition, the first two harmonics are excluded from the input factors because of their high correlation with the Wolf numbers. Thus, the third to sixth harmonics, which, in our opinion, are the most informative, were used for analysis.

The introduction of auxiliary harmonic trends, the “Sigma” factor is due to the internal inconsistency of the initial data of the system “Wolf numbers - infected with BLV”. With their help, the ANN is stabilized, training takes place for a much smaller number of epochs. The output parameter is still the trend “Infected with BLV”.

The first modification contained input factors synchronized in time from the beginning of the available trend of actual data on bovine leukosis (from 1994), the second modification was created retrogradely with counting from the current year (from 2022). Another subgroup of neural networks also belonged to the second modification by the period of analysis, but the ANN

packets in it were formed from the first to the ninth layer with accrual according to an odd pattern (modification 2.1).

Table 2 shows the coefficients for the two modifications.

In both cases, an information matrix was formed, having a period ( $T$ ) of rows and columns according to the number ( $N$ ) of factors under study. From this matrix the output parameter (% of infected BLV) was subjected to spectral analysis and several obtained harmonics according to their number were entered into the matrix as input parameters for ANN. The Wolf numbers with a shift of 1 year and the calculated coefficient “Sigma”, which has a qualitative discrete character, were also entered. After filling the initial calculation matrix in the program written in the R language, it generates several databases in the .dbf format for analysis in the NeuroPro program.

The number of neurons in a layer always remains 10 by default. The number of layers in the ANN, the number and composition of input factors in the part of auxiliary harmonics were changed in order to optimize the prediction. As a

result, 9 packages including more than 40 neural networks were created and the final tables were formed. Basically, the research was conducted in the direction of increasing the number of layers of the neural network, changing the composition of harmonics included in the initial matrix for analysis. In some ANNs, when increasing the number of layers, a significant scatter of data was noted. In others, on the contrary, the scatter of prediction was minimal. The combination of harmonics also affects the final value of the prediction.

Table 3 presents a starting modification in which the spectral analysis is performed from the beginning of a known period.

According to the presented modification when using five input factors but different number of neuron layers, the prediction of infection rate using ANN for 2023 ranges from 17.40 to 19.04%, with increasing number of input fields it ranges from 17.01 to 17.42%.

In the second modification, where input factors were synchronized from the end of the observation period, the increase in neuronal layers and input fields predicted a decrease in

**Табл. 2.** Коэффициенты спектральных моделей инфицированности ВЛКРС  
**Table 2.** Coefficients of spectral models of the BLV infection

Harmonic number	Coefficients of the spectral model of BLV infection rate							
	from 1994 till 2016				from 2000 till 2022			
	$A_{cos}$	$A_{sin}$	$A$	$\varphi$	$A_{cos}$	$A_{sin}$	$A$	$\varphi$
1	-1,166	6,494	6,704	-0,251	5,109	1,656	5,37	1,257
2	0,446	-1,173	1,255	-3,505	-1,299	1,709	2,146	-0,65
3	2,23	0,026	2,23	1,559	-0,331	2,33	2,353	-0,141
4	0,168	1,061	1,074	0,157	-0,49	0,763	0,907	-0,571
5	-0,209	0,186	0,28	-0,845	-1,079	-0,052	1,081	-1,619
6	-0,606	-0,458	0,759	-2,218	-0,723	0,375	0,815	-1,092
7	0,072	-0,5	0,505	-3,285	-0,678	0,349	0,763	-1,1
8	0,205	-0,273	0,342	-3,786	-0,671	0,055	0,674	-1,488
9	-0,752	-0,63	0,981	-2,268	-0,665	-0,922	1,137	-0,625
10	-0,048	-1,132	1,134	-3,099	-0,16	0,486	0,512	-0,318
11	0,638	-0,262	0,689	-4,323	-0,675	0,084	0,681	-1,448
$A_0$	16,5				15,665			

Note. A - amplitude,  $\varphi$  - phase,  $A_0$  - average of the numerical series.

BLV infection rate to 10.26–10.39% in 2023 (see Table 4).

Application of the modification of ANN formed by odd layers of neurons showed a decrease in the predicted value at the maximum number of neural network layers with input fields 3–5, according to which the virus carrier rate in 2023 should be 9.62; 8.84; 9.67%, respectively (see Table 5).

It should be noted that changing the composition of input fields influenced the magnitude of the predicted value. Thus, when using four input fields, but of different composition, the expected level of BLV carriage with the maximum number of layers in the ANN differed significantly,

**Табл. 3.** Параметры и прогнозы нейронных сетей (модификация 1)

**Table 3.** Parameters and forecasts of neural networks (modification 1)

Number of neuron layers	ANN-1 package		ANN -2 package	
	Number of input fields	Forecast for 2023, %	Number of input fields	Forecast for 2023, %
1	5	19,04	6	17,01
2	5	18,25	6	17,39
3	5	18,27	6	17,42
4	5	17,40	6	17,36
5	5	17,79	6	17,30

**Табл. 4.** Параметры и прогнозы нейронных сетей (модификация 2)

**Table 4.** Parameters and forecasts of neural networks (modification 2)

Number of neuron layers	ANN-3 package		ANN-4 package	
	Number of input fields	Forecast for 2023, %	Number of input fields	Forecast for 2023, %
1	5	19,50	6	12,30
2	5	17,70	6	16,39
3	5	19,95	6	15,69
4	5	21,11	6	10,26
5	5	20,19	6	10,39

**Табл. 5.** Итоговая статистика прогноза модификации 2.1, %

**Table 5.** Final statistics of the forecast of modification 2.1, %

Number of neuron layers	ANN-5 package	ANN -6 package	ANN -7 package	ANN -8 package	ANN -9 package
	Number of input fields				
	3	4	4	5	6
1	17,48	18,64	17,3	10,45	11,33
3	16,21	20,28	17,71	14,62	12,36
5	16,23	23,98	16,59	11,26	10,24
7	18,73	18,3	9,92	10,09	11,06
9	9,62	26,31	8,84	9,67	17,60

which in one case should be 26.31% in 2023, in the other – 8.84%.

When the number of layers was maximized and the input fields were increased to six, the number of BLV carriers was also predicted to increase to 17.6%.

## CONCLUSION

The level of cattle infection in the territory of the Omsk region according to the results of serologic studies in RID amounted to 16.8% in 2018, 14.5 in 2019, 17.6 in 2020, 15.6 in 2021, 14.0% in 2022, i.e. decreased by 1.16 times. Despite the decrease in the number of seropositive samples, BLV has a widespread and uneven tendency to spread in all administrative-territorial units of the region.

Several modifications of ANN have been created on the basis of the obtained data on diagnostic studies, consisting in optimization of the matrix of input factors and research of the influence of different numbers of layers of the neural network, which makes it possible to consider different scenarios of the expected development of the epizootic situation on bovine leukosis and to choose the most optimal models from the point of view of the researcher.

Further search for additional input factors, as well as ways to formalize the source material using alternative approaches of mathematical modeling will allow to increase the forecast period.

## СПИСОК ЛИТЕРАТУРЫ

1. Haredasht S.A., Vidal G., Edmondson A., Moore D., Del-Rio N.S., Lopez B.M. Characterization of the temporal trends in the rate of cattle carcass condemnations in the US and dynamic modeling of the condemnation reasons in California with a seasonal component // *Frontiers in Veterinary Science*. 2018. Vol. 5. N 87. DOI: 10.3389/fvets.2018.00087.
2. Bartlett P.C., Ruggiero V.J., Hutchinson H.C., Droscha C.J. Current developments in the epidemiology and control of enzootic bovine leukosis as caused by bovine leukemia virus // *Pathogens*. 2020. Vol. 9 (12). N 1058. DOI: 10.3390/pathogens9121058.
3. John E.E., Keefe G., Cameron M., Stryhn H., McClure J.T. Development and implementation of a risk assessment and management program for enzootic bovine leukosis in Atlantic Canada // *Journal of Dairy Science*. 2020. Vol. 103 (9). P. 8398–8406. DOI: 10.3168/jds.2019-17434.
4. Донник И.М., Гулюкин М.И., Бусол В.А., Коваленко Л.В., Коваленко А.М. Лейкоз крупного рогатого скота – диагностика, оздоровление, антропозоонозный потенциал (история вопроса) // *Сельскохозяйственная биология*. 2021. Т. 56. № 2. С. 230–244. DOI: 10.15389/agrobiology.2021.2.230rus.
5. Гулюкин М.И., Гулюкин А.М., Донченко А.С., Донченко Н.А. Анализ эпизоотической ситуации по лейкозу крупного рогатого скота в Сибирском федеральном округе // *Сибирский вестник сельскохозяйственной науки*. 2021. Т.51. № 4. С. 67–75. DOI.org/10.26898/0370-8799-2021-4-8.
6. Борисевич М.Н., Красочко П.А., Прищепа И.М. Модельные математические функции в практической биологии // *Вестник ВДУ*. 2018. № 3. С. 29–34.
7. Cedeno-Mieles W., Hu Z., Ren Y., Deng H., Contractor N., Ekanayake S. Data mining and pipeline modeling for controlled network experiments in the social sciences // *PLoS One*. 2020. Vol. 15 (11). P. E0242453. DOI: 10.1371/journal.pone.0242453.
8. Datilo P.M., Ismail Z., Dare J. A review of epidemic forecasting using artificial neural networks // *International Journal of Epidemiological Research*. 2019. Vol. 6. P. 132–143. DOI: 10.15171/ijer.2019.24.
9. Wu J.T., Cowling B.J. Real-time forecasting of infectious disease epidemics // *Hong Kong Medical Journal*. 2018. Vol. 24. Suppl. 6 (5). P. 26–29.
10. Manliura Datilo P., Ismail Z., Dare J. A review of epidemic forecasting using artificial neural networks // *International Journal of Epidemiological Research*. 2019. Vol. 6 (3). P. 132–143. DOI: 10.15171/ijer.2019.24.
11. Saba A.I., Elsheikh A.H. Forecasting the prevalence of COVID-19 outbreak in Egypt using non-linear autoregressive artificial neural networks // *Process Saf Environ Prot*. 2020. Vol. 141. P. 1–8. DOI: 10.1016/j.psep.2020.05.029.
12. Hong Y., Hou B., Jiang H., Zhang J. Machine learning and artificial neural network accelerated computational discoveries in materials science // *Wiley Interdisciplinary Reviews Computational Molecular Science*. 2020. Vol. 10. N. e1450. DOI: 10.1002/wcms.1450.
13. Cogollo M.R., González-Parra G., Arenas A.J. Modeling and forecasting cases of RSV using artificial neural networks // *Mathematics*. 2021. Vol. 9. N 2958. DOI: 10.3390/math9222958.
14. Власенко В.С., Борисов Е.С. Искусственная нейронная сеть в прогнозировании эпизоотической ситуации по лейкозу крупного рогатого скота // *Ветеринария и кормление*. 2023. № 1. С. 26–29. DOI: 10.30917/ATT-VK-1814-9588-2023-1-6.

## REFERENCES

1. Haredasht S.A., Vidal G., Edmondson A., Moore D., Del-Rio N.S., Lopez B.M. Characterization of the temporal trends in the rate of cattle carcass condemnations in the US and dynamic modeling of the condemnation reasons in California with a seasonal component. *Frontiers in Veterinary Science*, 2018, vol. 5, no. 87. DOI: 10.3389/fvets.2018.00087.
2. Bartlett P.C., Ruggiero V.J., Hutchinson H.C., Droscha C.J. Current developments in the epidemiology and control of enzootic bovine leukosis as caused by bovine leukemia virus. *Pathogens*, 2020, vol. 9 (12), no. 1058. DOI: 10.3390/pathogens9121058.
3. John E.E., Keefe G., Cameron M., Stryhn H., McClure J.T. Development and implementation of a risk assessment and management program for enzootic bovine leukosis in Atlantic Canada. *Journal of Dairy Science*. 2020. Vol. 103 (9). P. 8398–8406. DOI: 10.3168/jds.2019-17434.
4. Donnik I.M., Gulyukin M.I., Busol V.A., Kovalenko L.V., Kovalenko A.M. Bovine leukemia virus infection – diagnostics, eradication and anthrozoonotic potential (background review). *Sel'skohozyajstvennaya biolo-*

- giya = *Agricultural Biology*, 2021, vol. 56, no. 2, pp. 230–244. (In Russian). DOI: 10.15389/agrobiology.2021.2.230rus.
5. Gulyukin M.I., Gulyukin A.M., Donchenko A.S., Donchenko N.A. Analysis of the epizootic situation of cattle leukemia in the Siberian Federal District. *Sibirskii vestnik sel'skokhozyaistvennoi nauki = Siberian Herald of Agricultural Science*, 2021, vol. 51, no. 4, pp. 67–75. (In Russian). DOI: 10.26898/0370-8799-2021-4-8.
  6. Borisevich M.N., Krasochko P.A., Prishchepa I.M. Model mathematic functions in practical biology. *Vestnik VDU = Vestnik VSU*, 2018, no. 3, pp. 29–34. (In Russian).
  7. Cedeno-Mieles W., Hu Z., Ren Y., Deng H., Contractor N., Ekanayake S. Data mining and pipeline modeling for controlled network experiments in the social sciences. *PLoS One*, 2020, vol. 15 (11), P. E0242453. DOI: 10.1371/journal.pone.0242453.
  8. Datilo P.M., Ismail Z., Dare J. A review of epidemic forecasting using artificial neural networks. *International Journal of Epidemiologic Research*, 2019, vol. 6, pp. 132–143. DOI: 10.15171/ijer.2019.24.
  9. Wu J.T., Cowling B.J. Real-time forecasting of infectious disease epidemics. *Hong Kong Medical Journal*, 2018, vol. 24, suppl. 6 (5), pp. 26–29.
  10. Manliura Datilo P., Ismail Z., Dare J. A review of epidemic forecasting using artificial neural networks. *International Journal of Epidemiological Research*, 2019, vol. 6 (3), pp. 132–143. DOI: 10.15171/ijer.2019.24.
  11. Saba A.I., Elsheikh A.H. Forecasting the prevalence of COVID-19 outbreak in Egypt using nonlinear autoregressive artificial neural networks. *Process Saf Environ Prot*, 2020, vol. 141, pp. 1–8. DOI: 10.1016/j.psep.2020.05.029.
  12. Hong Y., Hou B., Jiang H., Zhang J. Machine learning and artificial neural network accelerated computational discoveries in materials science. *Wiley Interdisciplinary Reviews Computational Molecular Science*, 2020, vol. 10, no. e1450. DOI: 10.1002/wcms.1450.
  13. Cogollo M.R., González-Parra G., Arenas A.J. Modeling and forecasting cases of RSV using artificial neural networks. *Mathematics*, 2021, vol. 9, no. 2958. DOI: 10.3390/math9222958.
  14. Vlasenko V.S., Borisov E.S. Artificial neural network in forecasting of the epizootic situation on the leukosis of cattle. *Veterinariya i kormlenie = Veterinaria i kormlenie*, 2023, no. 1, pp. 26–29. (In Russian). DOI: 10.30917/ATT-VK-1814-9588-2023-1-6.

#### ИНФОРМАЦИЯ ОБ АВТОРАХ

**Власенко В.С.**, доктор биологических наук, профессор, главный научный сотрудник

**Борисов Е.С.**, ведущий специалист

✉ **Новикова Н.Н.**, кандидат ветеринарных наук, ведущий научный сотрудник; **адрес для переписки:** Россия, 644001, Омск, ул. Лермонтова, 93; e-mail: Novikova@anc55.ru

#### AUTHOR INFORMATION

**Vasily S. Vlasenko**, Doctor of Science in Biology, Professor, Head Researcher

**Eugeny S. Borisov**, Lead Researcher

✉ **Natalia N. Novikova**, Candidate of Science in Veterinary Medicine, Lead Researcher; **address:** 93, Lermontova St., Omsk, 644001, Russia; e-mail: Novikova@anc55.ru

Дата поступления статьи / Received by the editors 11.06.2024  
Дата принятия к публикации / Accepted for publication 06.08.2024  
Дата публикации / Published 20.11.2024

## Сравнительная оценка производственных платформ для получения вакцин на основе куриных яиц и биотехнологий тутового шелкопряда

✉ Юматов Е.Н.<sup>1,2</sup>, Евлагина Е.Г.<sup>2</sup>, Евлагин В.Г.<sup>2</sup>, Лейнвебер Е.Ф.<sup>2</sup>

<sup>1</sup>Индивидуальный предприниматель

Самара, Россия

<sup>2</sup>Научно-исследовательская станция шелководства – филиал Северо-Кавказского федерального научного аграрного центра

Ставропольский край, г. Железноводск, Россия

✉ e-mail: trast1207@mail.ru

Вакцины являются известной и наиболее экономически эффективной стратегией предотвращения и подавления глобальных инфекций. Для безопасного, быстрого и крупномасштабного производства вакцин разрабатываются новые производственные платформы, внедрение которых способно устранить присущие традиционным производствам недостатки. Помимо этого, создаются новые системы стабилизации и доставки вакцин для устранения зависимости от «холодовой цепи». Сравнительная оценка традиционной, наиболее широко распространенной в мире платформы на основе куриных яиц и биотехнологической платформы на основе тутового шелкопряда (*Bombyx mori*), предлагаемой к использованию в качестве альтернативы, является целью данного обзора. С точки зрения системы здравоохранения, грипп продолжает оставаться единственной болезнью человека, требующей ежегодной вакцинации. Исходя из этого, представленный обзор отражает в большей степени специфику данного направления. Комплексная сравнительная оценка ключевых производственных показателей на этапах восходящего (USP) и нисходящего (DSP) процессов, отражающая их эффективность, показала значительное преимущество биотехнологических решений на основе тутового шелкопряда перед платформой на основе яиц. Кроме того, возможность эффективного использования как основного (оболочка кокона, из которой после переработки получают биоматериалы для стабилизации и доставки вакцин), так и вторичного сырья (куколка тутового шелкопряда, выступающая в качестве биореактора для продуцирования целевого белка (гемагглютинина, HA)) показывает преимущества платформы на основе тутового шелкопряда и с точки зрения сырьевой универсальности по сравнению с платформой на основе куриных яиц, а также относительно другой альтернативной производственной платформой, разработанной на базе биотехнологий совки ни (*Trichoplusia ni*).

**Ключевые слова:** тутовый шелкопряд, куколка, SPF-яйца, платформы для производства вакцин, стабилизация и доставка вакцин, производственная эффективность

## Comparative evaluation of production platforms for chicken egg-based vaccines and mulberry silkworm biotechnology

✉ Yumatov E.N.<sup>1,2</sup>, Evlagina E.G.<sup>2</sup>, Evlagin V.G.<sup>2</sup>, Leinweber E.F.<sup>2</sup>

<sup>1</sup>Sole entrepreneur

Samara, Russia

<sup>2</sup>Research Station of Sericulture – Branch of North Caucasus federal agricultural research centre  
Zheleznovodsk, Stavropol region, Russia

✉ e-mail: trast1207@mail.ru

Vaccines are well-known and the most cost-effective strategy for preventing and suppressing global infections. New manufacturing platforms are being developed for safe, rapid and large-scale production, the implementation of which can eliminate the inherent drawbacks of traditional production. Furthermore, new vaccine stabilization and delivery systems are being developed to overcome dependence on the "cold chain". The objective of this review is to compare the traditional and most widely used egg-based platform with a potential biotechnological platform based on silkworm (*Bombyx mori*) as an alternative platform. From a public health perspective, influenza remains the only human

disease that requires annual vaccination. For this reason, the presented review largely reflects the peculiarities of this direction. A comprehensive comparative assessment of key manufacturing indicators at the stages of USP and DSP, reflecting their effectiveness, showed a significant advantage of mulberry silkworm-based biotechnological solutions over egg-based platform. The possibility of effectively using the obtained raw materials, both primary (cocoon shell from which biomaterials are obtained for stabilization and vaccine delivery after processing), and secondary, mulberry silkworm pupa which serves as a bioreactor for the production of the target protein (hemagglutinin, HA) shows the advantages of the mulberry silkworm-based platform and in terms of raw material versatility compared to the chicken egg-based platform, and relative to another alternative production platform developed based on cabbage looper (*Trichoplusia ni*) biotechnology.

**Keywords:** mulberry silkworm, pupa, SPF eggs, vaccine production platforms, vaccine stabilization and delivery, production efficiency

**Для цитирования:** Юматов Е.Н., Евлагина Е.Г., Евлагин В.Г., Лейнвебер Е.Ф. Сравнительная оценка производственных платформ для получения вакцин на основе куриных яиц и биотехнологий тутового шелкопряда // Сибирский вестник сельскохозяйственной науки. 2024. Т. 54. № 10. С. 93–107. <https://doi.org/10.26898/0370-8799-2024-10-10>

**For citation:** Yumatov E.N., Evlagina E.G., Evlagin V.G., Leinweber E.F. Comparative evaluation of production platforms for chicken egg-based vaccines and mulberry silkworm biotechnology. *Sibirskii vestnik sel'skokhozyaistvennoi nauki = Siberian Herald of Agricultural Science*, 2024, vol. 54, no. 10, pp. 93–107. <https://doi.org/10.26898/0370-8799-2024-10-10>

#### Конфликт интересов

Авторы заявляют об отсутствии конфликта интересов.

#### Conflict of interest

The authors declare no conflict of interest.

#### Благодарность

Исследование выполнено за счет гранта Российского научного фонда № 23-26-00247 (<https://rscf.ru/project/23-26-00247/>).

#### Acknowledgements

The research was carried out at the expense of the grant from the Russian Science Foundation No. 23-26-00247 (<https://rscf.ru/project/23-26-00247/>).

## INTRODUCTION

Vaccination is the most effective measure for preventing influenza virus infection. Many next-generation vaccines, developed using innovative methods that reduce production time and expand the spectrum of vaccine efficacy, are currently in the development stage [1]. Currently, three types of vaccines are used worldwide: inactivated influenza vaccine (IIV), live attenuated influenza vaccine (LAIV), and recombinant vaccine (HA). Inactivated vaccines are divided into: 1) whole-virus (whole-cell) vaccines; 2) split-virus (split) vaccines; and 3) subunit vaccines<sup>1</sup> [2].

As a rule, vaccines are produced using chicken eggs (traditional method) and cell culture [2]. E. Sparrow et al. [3], reviewing global experience in the production of vaccines against sea-

sonal and pandemic influenza, note that most of them are manufactured using the chicken embryo cultivation method, accounting for 84.5% of global production capacity, while the share of cell-based vaccines is 15.5%. R. Nuwarda et al. [2] classify the following as new platforms for influenza vaccine production: virus-like particle (VLP)-based vaccines; antigen-presenting cell (APC)-induced vaccines; nanoparticle-based vaccines; and universal vaccines (providing long-term protection and having a broad spectrum of action).

R. Cid and J. Bolivar [4] presented their classification: 1) traditional platforms for protein vaccine production—these include bacteria (*Escherichia coli*), yeast, insect cells, and mammalian cells used as platforms for producing recombinant proteins; 2) new alternatives—non-*E.*

<sup>1</sup>Grohskopf L., Alyanak E., Broder K., Blanton L., Fry A., Jernigan D., Atmar R. Prevention and Control of Seasonal Influenza with Vaccines: Recommendations of the Advisory Committee on Immunization Practices (United States, 2020/21 Influenza Season)// MMWR. Recommendations and reports: Morbidity and mortality weekly report, 2020, vol. 69, N 8, pp. 1–24.

*coli* bacterial systems, the use of unconventional strains in yeast platforms, transgenic animals, insects, plant-based systems, and microalgae. Among the recombinant protein-based vaccines approved for human use, yeast and insect cells are the most widely used production platforms. Characterizing the insect-based platform, the authors note that the baculovirus expression vector system (BEVS) is not limited to insect cell cultures. Their larvae or pupae can also be used for the production of recombinant proteins. Industrial production using insect cells, like any other cultured cells, requires artificial media and expensive bioreactors. Protein expression using insect larvae as biofactories offers a cost-effective alternative to insect cell bioreactors and the ability to produce large and multiple proteins with simple production scaling. This system has the advantage of high levels of protein expression with post-translational modifications of complex proteins. Within this platform, the most promising insect species are the mulberry silkworm (*Bombyx mori*) and the cabbage looper (*Trichoplusia ni*).

Chemical and physical pathways of vaccine degradation, initiated by light, air pollutants, as well as by temperature fluctuations, agitation, ionic strength and pH changes during freeze-thaw cycles, facilitate the deployment of antigens, exposing the regions that serve as their attachment points to form large insoluble particles, jeopardizing vaccine stability<sup>2</sup> [5]. Considering different approaches and substances for stabilization of liquid vaccines (sugars, surfactants, amino acids), as well as approaches to stabilization of solid vaccines (freeze drying, spray drying (alternative to lyophilization), film-based dosage forms), I. Bajrovic et al. [6, 7] predict that within the next 10 years there will be a massive transition to alternative methods of vaccine stabilization in response to cold chain problems. Silkworm cocoon shell derivatives, after downstream processing, are used to create means for stabilization and delivery of vaccines.

Various terms are used to describe the traditional platform where chicken eggs are used as raw material: “vaccine produced by cultivation in chicken embryos”, “chicken embryo-based vaccine”, “vaccines produced in fertilized chicken eggs”, or “egg-based vaccine”. Within this article, the term “egg-based vaccine” will be used. Additionally, to avoid ambiguity, the concept of a vaccine production platform will be interpreted according to the classification by R. Cid and J. Bolivar [4] as the host system in which target proteins are produced: chicken eggs, bacteria (*E. coli*), yeast, insect cells, and mammalian cells.

The concepts of upstream and downstream processes, or initial and subsequent processing (Upstream/Downstream Process(ing), USP and DSP), are most common in the biopharmaceutical industry. An analogue of the process of cultivating microorganisms, cells, or viruses is the rearing of silkworms. In both cases, the goal of the upstream process is to obtain raw materials, while the downstream process aims to purify them from impurities to obtain the final target product. For example, M. McNulty et al. [8], in a techno-economic analysis of a plant-based platform for the production of antimicrobial peptides, classify the cultivation of plant seedlings as upstream processing (USP) and all subsequent processes, from harvesting to purification, as downstream processing (DSP). Thus, based on the essence of the processes at the upstream and downstream stages of production, it is appropriate to use the terminology of USP and DSP in the context of this article regarding the discussed production platforms.

The purpose of our research is a comparative evaluation of the traditional, most widely used egg-based platform worldwide and a potential alternative based on silkworm biotechnology.

## MATERIAL AND RESEARCH RESULTS

### *USP biotechnologies*

In the comparative analysis, the biotechnologies of the upstream process for both the egg-

<sup>2</sup>Ohtake S., Kita Y., Arakawa T. Interactions of formulation excipients with proteins in solution and in the dried state // Advanced drug delivery reviews, 2011, vol. 63, N 13, pp. 1053–1073.

based platform and the *B. mori*-based platform refer to the production of raw materials: SPF eggs (specific pathogen-free eggs) and silkworm cocoons. The *B. mori* cocoon is a shell containing a pupa inside. In traditional sericulture, the most valuable and primary raw material is the cocoon shell, while the silkworm pupa is a byproduct or secondary raw material. The 'bottom-up' approach, based on transient expression methods, allows the use of the pupa as a bioreactor for producing target proteins, similar to a chicken egg.

*Transient expression system of B. mori  
for the production of VLP*

T. Motohashi et al.<sup>3</sup> reported the creation of the first BmNPV bacmid system. Using this system, they demonstrated a high level of green fluorescent protein (GFP) gene expression in pupae, silkworm larvae and its cell line by direct injection of recombinant bacmid DNA as well as recombinant baculoviruses. The BmNPV bacmid system using mulberry silkworm biotechnology was evaluated as very attractive because of its low cost (about 10% of the cost of expression in insect cells), high biosafety. In addition, the system under consideration is a great breakthrough in the production of recombinant eukaryotic proteins and viruses, suitable for large-scale production.

A. Usami et al.<sup>4</sup>, using a hybrid baculovirus system, compared 45 recombinant proteins from six categories on two models: mulberry silkworm (larvae and pupae) and cell line Sf 9 (*Spodoptera frugiperda*). The authors noted that silkworm-based production is more efficient: one individual mulberry silkworm produces about 70 times more protein than 10<sup>6</sup> Sf 9 cells in 2 ml of culture medium.

K. Nerome et al.<sup>5</sup> reported the possibility of large-scale production of an artificial vaccine

based on virus-like particles (VLP) in mulberry silkworm pupae. In the expression system established by the scientists, four days after inoculation of pupae with a recombinant baculovirus containing a synthetic hemagglutinin H5 (HA) gene optimized for mulberry silkworm codons, the hemagglutination titer in homogenates of infected pupae reached an average value of 0.8 million hemagglutination units (HAU), which is approximately 2,000 mg of HA protein per pupa and more than 50 times higher than that of a chicken egg. The homogenates showed VLPs with diameters ranging from 30 to 300 nm, covered with a large number of spines. The spines were about 14 nm long, which was similar to the true HA spines in influenza. Detailed electron micrographs showed that the density of VLP spikes was similar to that of genuine influenza virus particles.

K. Maegawa et al. [9] created four recombinant baculoviruses derived from *B. mori* nuclear polyhedrosis virus (BmNPV) and *Autographa californica* nuclear polyhedrosis virus (AcNPV) for the production of mono- and bivalent influenza vaccines consisting of virus-like particles containing hemagglutinin. *B. mori* and *Eri* silkworm pupae were used to produce VLP-based vaccines by infecting them with recombinant BmNPV and AcNPV viruses. Inoculation with the two recombinant viruses resulted in bivalent vaccines containing very similar amounts of H5 and H7 antigens. The HA titer of the isolated bivalent vaccine was 838,808, including 62% H5 antigen (H5 HA titer: 524,144) and 38% H7 antigen (H7 HA titer: 314,644). Thus, the authors demonstrated the feasibility of large-scale production of bivalent vaccines.

K. Nerome et al. [10] successfully created a chimeric cytokine (CC) containing M2 protein, influenza A neuraminidase stem and interleu-

<sup>3</sup>Motohashi T., Shimojima T., Fukagawa T., Maenaka K., Park E. Efficient large-scale protein production of larvae and pupae of silkworm by *Bombyx mori* nuclear polyhedrosis virus bacmid system // Biochemical and biophysical research communications, 2005, vol. 326, N 3, pp. 564–569.

<sup>4</sup>Usami A., Ishiyama S., Enomoto C., Okazaki H., Higuchi K., Ikeda M., Nagaya H. Comparison of recombinant protein expression in a baculovirus system in insect cells (Sf9) and silkworm // The journal of biochemistry, 2011, vol. 149, N 2, pp. 219–227.

<sup>5</sup>Nerome K., Sugita S., Kuroda K., Hirose T., Matsuda S., Majima K., Nerome R. The large-scale production of an artificial influenza virus-like particle vaccine in silkworm pupae // Vaccine, 2015, vol. 33, N 1, pp. 117–125.

kin-12. They produced virus-like particles containing CC and influenza hemagglutinin proteins using the baculovirus system in *Eri* silkworm pupae. This is the first study to develop an HA-VLP vaccine containing CC, confirming its efficacy against different strains of influenza virus, laying the foundation for the development of a universal influenza vaccine.

#### *Mulberry silkworm pupa and chicken egg as bioreactors*

The production of recombinant derivatives is possible in different parts of the mulberry silkworm during its life cycle: in the hemolymph and fat body of the larva, pupa, cocoon sheath, fibroin and sericin layers. It is the pupa that is the most efficient for VLP production (for more details see Sect. "Possible explanation for the significant difference in the yield of recombinant derivatives after purification").

In the framework of the traditional platform, the raw material is SPF eggs. One of the important factors affecting the technology of influenza vaccine production is the quality of the raw material used (chicken embryo). The amount of active agent produced – hemagglutinin – depends on it. P.E. Vandyshev, investigating the increase in the efficiency of the use of egg cross embryos in the production of influenza vaccines, found that the most optimal age of chickens in the production of chicken embryos is 270–450 days. During this period, the volume of extracted allantois fluid reaches 8.3 ml with a loss rate of no more than 10%; up to 70 µg of hemagglutinin can be obtained when purified by tangential filtration<sup>6</sup> [11]. Fig. 1 shows the average values of weight and length of mulberry silkworm pupa, chicken eggs and embryos<sup>7, 8</sup> [11–13], fig. 2 shows the ratio of cocoon and pupal sizes of silkworm and chicken eggs.

#### *DSP biotechnologies*

The downstream process includes purification of target proteins from mulberry larvae or pupae, collection of virus-containing allantois fluid from chicken eggs and purification of hemagglutinin. The cocoon shell of *B. mori* cocoon is processed to produce biomaterials: fibroin (SF), sericin (SS), and composites of fibroin and sericin. SF can be used, among other things, for the production of stabilization agents and vaccine delivery.

#### *Purification of vaccine viruses and virus-like particles*

The yield of active agent (hemagglutinin in mulberry pupae and allantois fluid in hen egg embryos) after purification is a key indicator of production efficiency in a top-down process. HA content is expressed in milligrams per 100 eggs. For mulberry silkworms, researchers report data for one or more larvae or pupae. Selected data on purification methods and yield of active agent after purification are presented in Table 1.

#### *Possible explanation for the significant difference in the yield of recombinant derivatives after purification*

The apparent difference in the yield of target proteins after purification between silkworm larva and pupa finds explanation in research data. Thus, H. Yagi et al. [14], studying mulberry silkworm pupae and larvae as producers of recombinant glycoproteins (IgG) labeled with stable isotopes, compared the yield of IgG in larvae and pupae. The yields of recombinant IgG purified from the hemolymph fluid of larvae and pupae whole body homogenates were 0.07 and 0.35 mg, respectively. Thus, pupal extracts showed 5 times higher yield than larval extracts. BmNPV infects blood cells and fat cells of mulberry silkworm. The pupal body tissues are mainly composed of body fat cells, which can express

<sup>6</sup>Vandyshev P.E. Increasing the efficiency of chicken embryos of egg crosses in the production of influenza vaccines: Candidate's thesis, Ryazan, 2023, 127 p.

<sup>7</sup>Burova D., Trubitsyn M. SPF egg production: current status and challenges // IOP Conference Series: Earth and Environmental Science, 2021, vol. 937, N 3, p. 032028.

<sup>8</sup>Kamtongdee C., Sumriddetchkajorn S., Sa-Ngiamsak C. Feasibility study of silkworm pupa sex identification with pattern matching // Computers and electronics in agriculture, 2013, vol. 95, pp. 31–37.

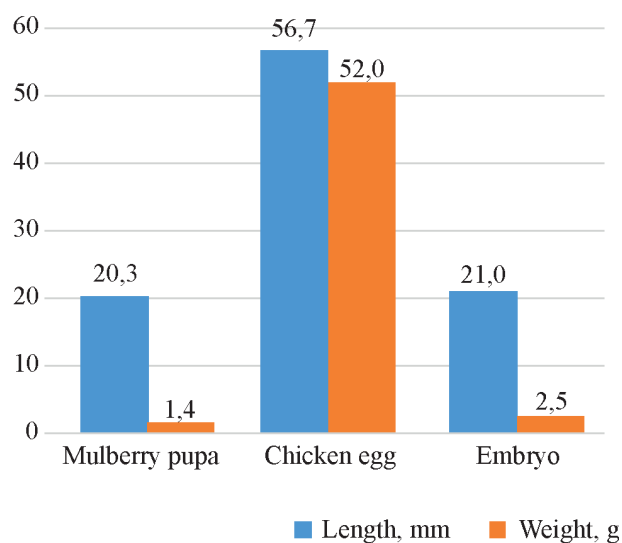

**Рис. 1.** Морфометрические показатели куколки *B. mori*, куриных яиц и эмбрионов

**Fig. 1.** Comparative morphometric parameters of *B. mori* pupa, eggs and embryos

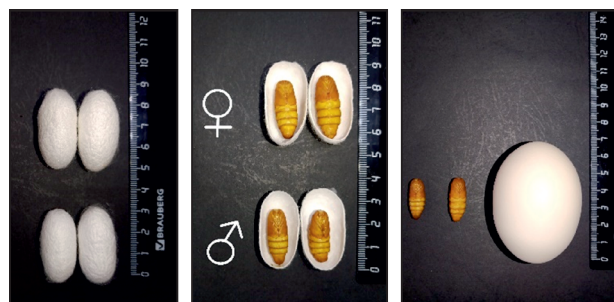

**Рис. 2.** Визуализация коконов с живыми куколками тутового шелкопряда и куриного яйца

**Fig. 2.** Visualization of cocoons with live mulberry silkworm pupae and a chicken egg

recombinant proteins. For this reason, recombinant IgG can be obtained from homogenates of the whole pupal body. In contrast, because the larval midgut contains a large number of proteases, body fluid must be extracted before purification of recombinant protein<sup>9</sup> [15, 16]. This may be the reason for the higher yield of recombinant IgG in pupae.

### Comparison of different purification methods for influenza vaccine production

The presence of ovalbumin (OVA) in the vaccine, which constitutes more than 60% of the total protein in the allantois fluid, can lead to severe allergies. Hence, effective reduction of ovalbumin is crucial for vaccine production. Comparing two methods of influenza virus purification and concentration (zone gradient ultracentrifugation and combined ultrafiltration/diafiltration and exclusion chromatography protocol) used for seasonal vaccine production, N. Asanzhanova et al.<sup>10</sup> found that combined chromatography was comparable to the zone centrifugation protocol in terms of ovalbumin removal results. Comparison of the data revealed no noticeable differences in the content of HA, proteins, and OVA. The concentration of HA in the obtained preparation was 102.8–119.5 µg/ml, which corresponded to the preservation of 54.5–68.8% of HA in the chromatographic method of purification. For centrifugation, the HA content was 297.1–401.2 µg/ml, which was equivalent to the retention of 61.7–74.1% HA in the resulting product. Purification by both methods resulted in 1.62–2.50 (chromatography) and 1.3–3.2 µg/ml (ultracentrifugation) of the purified viral material.

### Application of silk proteins for vaccine stabilization and delivery

Sensitive biological compounds, such as vaccines and antibiotics, traditionally require a time-dependent cold chain to maintain therapeutic activity. The establishment of a single cold chain can account for 80% of the total financial cost of vaccination<sup>11</sup>. Losses due to transportation and storage violations can amount to billions of dollars, severely limiting vaccination options in developing countries. To address these major

<sup>9</sup>Franzetti E., Huang Z., Shi Y., Xie K., Deng X., Li J., Feng Q. Autophagy precedes apoptosis during the remodeling of silkworm larval midgut // *Apoptosis*, 2012, vol. 17, pp. 305–324.

<sup>10</sup>Asanzhanova N., Ryskeldinova S., Chervyakova O., Khairullin M., Kasenov M., Tabynov K. Comparison of different methods of purification and concentration in production of influenza vaccine // *Bulletin of Experimental Biology and Medicine*, 2017, vol. 164, pp. 229–232.

<sup>11</sup>Chen X., Fernando G., Crichton M., Flaim C., Yukiko S., Fairmaid E., Kendall M. Improving the reach of vaccines to lowresource regions, with a needle-free vaccine delivery device and long-term thermostabilization // *Journal of controlled release*, 2011, vol. 152, N 3, pp. 349–355.

**Табл. 1.** Показатели выхода после очистки вирусов и вирусоподобных частиц из эмбрионов куриных яиц, личинок и куколок тутового шелкопряда

**Table 1.** Yield rates after purification of viruses and virus-like particles from chicken egg embryos, larvae and pupae of mulberry silkworms

Name	Purification method	Finished product yield	Sources*
<i>Mulberry silkworm larvae and pupae</i>			
Avian influenza virus protein (hemagglutinin H7)	Centrifugation in sucrose density gradient	1832 µg/doll; 90% of the HA fraction was present as the heavy fraction; in addition, most of the VLP was extracted from the heavy fraction in a purified form	1
Bivalent vaccines VLP		12 ml/20 pupae, 5 ml/10 pupae	2
<i>Chicken embryos</i>			
HA protein	Tangential filtering	Up to 70 µg/egg	3
Viral protein in virions concentrated from allantois fluid	Chemical inactivation and purification used in production (e.g., sucrose density gradient ultracentrifugation and/or chromatography)	1,4–27,0 mg/100 eggs	4
HA in virus concentrates (purified viruses)		The maximum yield is about 10.5 mg/100 eggs	
HA in purified virus samples	Ultracentrifugation using a linear sucrose density gradient	Relative content of HA 8,5–48,4%	5
Total viral protein		About 1,8–8,0 mg/100 eggs	
HA in vaccine and recombinant viruses		About 0,5–3,0 mg/100 eggs	

\*Sources: 1) Nerome K., Matsuda S., Maegawa K., Sugita S., Kuroda K., Kawasaki K., Nerome R. Quantitative analysis of the yield of avian H7 influenza virus haemagglutinin protein produced in silkworm pupae with the use of the codon-optimized DNA: A possible oral vaccine // *Vaccine*, 2017, vol. 35, N 5, pp. 738–746; 2) Maegawa K., Sugita S., Arasaki Y., Nerome R., Nerome K. Interleukin 12-containing influenza virus-like-particle vaccine elevate its protective activity against heterotypic influenza virus infection // *Heliyon*, 2020, vol. 6, N 8, p. 04543; 3) Vandyshev P.E. Increasing the efficiency of the use of chicken embryos of egg crosses in the production of influenza vaccines: Candidate's thesis in Agriculture. Ryazan, 2023, 127 p.; 4) Johnson A., Chen L., Winne E., Santana W., Metcalfe M., Mateu-Petit G., Donis R. Identification of influenza A/PR/8/34 donor viruses imparting high hemagglutinin yields to candidate vaccine viruses in eggs // *Plos one*, 2015, vol. 10, N 6, p. 0128982; 5) Guan L., Ping J., Lopes T., Fan S., Presler R., Neumann G., Kawaoka Y. Development of an Enhanced High-Yield Influenza Vaccine Backbone in Embryonated Chicken Eggs // *Vaccines*, 2023, vol. 11, N 8, p. 1364.

limitations, J. Zhang et al.<sup>12</sup> proposed silk protein biomaterial matrices capable of stabilizing labile vaccines and antibiotics at temperatures up to 60 °C for more than 6 months. Live measles, mumps and rubella (MMR) vaccines were the model vaccines for studying the stabilization effect of silk matrices. Encapsulation in silk films increased stability (expressed as the residual activity remaining after storage compared to the initial activity) at elevated temperatures. Silk was shown to be an effective carrier material for increasing the thermostability of both antibiotics

and vaccines. Silk protein-based films allowed to increase the half-life of the vaccine, reduce unfolding and subsequent aggregation of proteins by reducing residual moisture during storage at elevated temperatures, provide structural stability of the vaccine at elevated temperatures affecting denaturation of viral proteins.

J. Stinson et al. [17] presented their development – air-dried thin films for temperature stabilization of polio vaccine (IPV) using silk fibroin-based biomaterial. The thin film compositions were optimized for physical properties as

<sup>12</sup>Zhang J., Pritchard E., Hu X., Valentin T., Panilaitis B., Omenetto F.G., Kaplan D.L. Stabilization of vaccines and antibiotics in silk and eliminating the cold chain // *Proceedings of the National Academy of Sciences of the United States of America*, 2012, vol. 109, N 30, pp. 11981.

well as for poliovirus D-antigen recovery and tested under accelerated storage and real-time stability conditions. IPV films made from silk fibroin retained 70% of the D-antigen activity for almost three years when stored at room temperature and more than 50% of the activity of serotypes IPV-2 and IPV-3 at 45 °C for one year. Later J. Stinson et al. [18] to achieve stable kinetics of vaccine delivery developed a patch with silk fibroin-based micro-needles (MIMIX) that contain the vaccine, embed into the dermis after brief application to the skin, and release antigen within 1–2 weeks, mimicking the time course of a natural influenza infection. In a preclinical mouse model, a single injection of influenza vaccine using MIMIX resulted in faster seroconversion, a response equivalent to bolus immunization with prime-boost, higher HAI titers against drifting influenza strains, and improved protection against lethal influenza infection compared to intramuscular injection. These results emphasize that infection mimicry achieved with prolonged-release silk micro-needles is a viable approach to improve existing seasonal influenza vaccines, accounts for the broader potential of this platform technology to create more effective next-generation vaccines and vaccine combinations.

In 2023, Vaxess was the first company in the world to complete a Phase I trial of a vaccine patch with dissolving silk protein-based micro-needles with a delayed-release effect. The study, conducted on 45 healthy patients, evaluated the delivery of H1N1 influenza antigen (GC Biopharma Corp.) using the MIMIX™ patch (Vaxess), safety, reactogenicity, tolerability and immunogenicity profiles for two doses of influenza vaccine (a fractionated dose of 7.5 mcg H1 vaccine and a standard dose of 15 mcg H1 vaccine compared to placebo), duration of the immune response for each dose and breadth of responses to influenza H1 antigen<sup>13</sup>.

### *An alternative platform for B. mori biotechnology-based vaccine production, stabilization and delivery*

Among the biotechnological solutions aimed at improving the production and economic performance of traditional silk breeding, as well as to obtain new types of products, the possibility of using artificial nutrient medium (ANM) for year-round cultivation of *B. mori* is a basic improvement, which, in conjunction with a variety of biotechnological methods used at the stages of upward and downward processes, allows to obtain a wide range of new biomaterials to meet the needs of regenerative silk breeding and biomedicine [19]. The option of efficient use of not only primary but also secondary raw materials helps to optimize the use of raw material resources, which generally increases productivity and reduces costs. The main steps of the USP and DSP processes of the *B. mori*-based platform are summarized in fig. 3.

### *Production efficiency indicators of biotechnology platforms*

The quantitative index of target protein production in mulberry silkworm pupa and chicken egg in the ascending process and the yield of purified protein in the descending process characterize the efficiency of their use as bioreactors or conditional raw material units. The general indicators characterizing the efficiency of the whole platform are: raw material productivity and yield of the final product obtained from this raw material for a comparable period of time.

The following data were used to determine raw material productivity:

1. The main production indicators for laying hens are planting density, productive period, egg productivity [20].

2. Parameters of Univent 550 and Univent 600 cage batteries with laying hens. 4 or 5 tier version is possible<sup>14</sup>. With the 4-tier version the total height of the construction is 2550 mm. With a distance of 150 mm between the racks on

<sup>13</sup><https://www.vaxess.com/news-vaxess-2023-year-in-review>

<sup>14</sup><https://www.agriexpo.ru/prod/big-dutchman/product-171220-10433.html>

which the mulberry silkworm is reared, 17 tiers correspond to the height of the cage battery.

3. Duration of the productive period of laying hens is from the 22nd to 78th week of life [20], i.e. approximately 392 days. The duration of the rearing period of the Russian breed of mulberry silkworm Kavkaz-2 is about 45 days [21]. Thus, for 392 days, 8.7 cycles of *B. mori* rearing can be carried out consecutively. In one cycle, the cocoon shell and pupa of the mulberry silkworm can be obtained.

4. The density of mulberry silkworm rearing is an indicator of raw material yield, which takes into account the need for additional area required for cocoon curling (similar to the area for rearing silkworm larvae). The viability of the mulberry silkworm is 94% [21].

Comparative characteristics of the main production indicators of USP- and DSP-stages for laying hens and mulberry silkworm are presented in Table 2.

### *An alternative platform for Trichoplusia ni-based vaccine production*

J. Escribano et al. [22] presented studies in which the baculovirus expression vector system (BEVS) using the pupa of the cabbage looper (*T. ni*) as a bioreactor was applied to produce a recombinant subunit vaccine. The technology, named CrisBio, was tested for the production of dozens of proteins.

Its productivity reached several milligrams per infected pupa. The production of CrisBio biopharmaceuticals was industrialized through the development of disposable plastic devices for insect rearing and pupa storage, compatible with machines specifically designed to automate pupa handling and inoculation. Robotic and intelligent systems were used to analyze quality and reject pupae based on physical criteria, move selected pupae into plastic trays, and inoculate them at a rate of about 3,000 pupae per hour. Extraction and purification of VLPs were

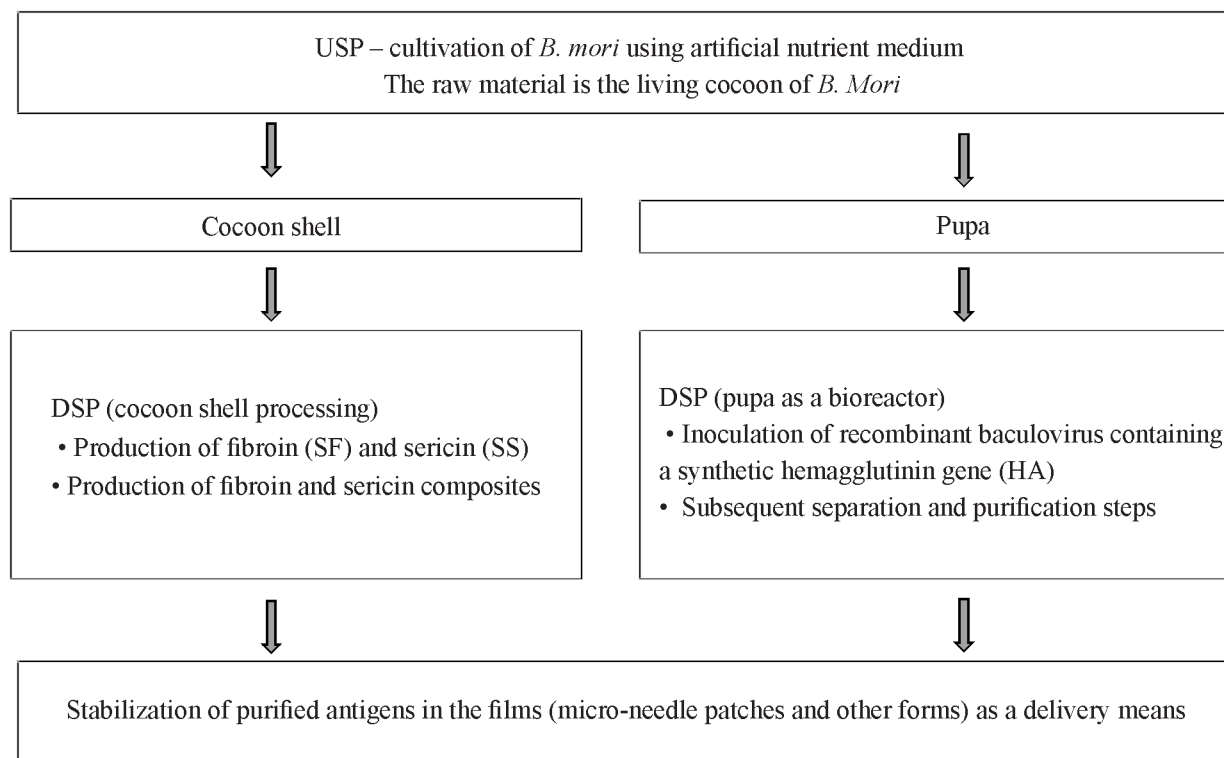

**Рис. 3.** Блок-схема основных процессов USP и DSP для получения и стабилизации вакцин на основе биотехнологий *B. mori*

**Fig. 3.** Flowchart of the main USP and DSP processes for the preparation and stabilization of *B. mori* biotechnology-based vaccines

carried out using homogenization methods in phosphate-buffered saline (PBS) extraction buffer and recovery using protease inhibitors, followed by clarification, diafiltration, purification, and ultrafiltration steps to obtain purified VLPs. The authors note that CrisBio technology, unlike standard operating procedures used in bioreactors, is extremely simple and reliable. The capital and operating costs of this technology platform are a fraction of those required for bioreactor-based technologies. Its advantage is its linear scalability, which depends only on the number of infected pupae under predetermined conditions. The stability of *T. ni* pupal production is very high and comparable to that in cultured insect cells using the same recombinant baculovirus vector, but CrisBio is not affected by environmental quality, relative gas concentration or cell contamination as is the case with bioreactor-based technologies. The productivity of recombinant proteins in CrisBio, measured by the concentration of recombinant protein obtained from 1 g of fresh insect biomass, varies on average from 2 to 5 mg/g of final product, in some cases productivity exceeds 10 mg/g. In addition, the process is very

versatile, as the biomass of infected pupae can be stored frozen at  $-20\text{ }^{\circ}\text{C}$  for at least two years without significant degradation of the recombinant proteins.

A. Falcón et al. [23] presented a subunit vaccine based on influenza HA against pandemic avian influenza in *T. ni* pupae in combination with baculovirus vectors (using CrisBio® technology). The HA yield after extraction and purification by affinity chromatography was approximately 75 mg/l. The authors note that despite the perceived complexity, in practice the purification process was quite easy. The absence of ovalbumin, which is an impurity in hen egg-based vaccines, eliminated potential adverse reactions in recipients. Moreover, influenza virus inactivation or organic extraction procedures were unnecessary, mitigating potential denaturing effects and safety concerns arising from residual toxic chemicals in the vaccine. Cost analysis showed that 4 times less investment was required to organize production of recombinant biological drugs using CrisBio® technology compared to the costs of setting up GMP-compliant production using insect cell cultivation.

**Табл. 2.** Примерные сравнительные характеристики основных производственных показателей USP- и DSP-этапов для кур-несушек и тутового шелкопряда

**Table 2.** Approximate comparative characteristics of the main production indicators USP and DSP stages for laying hens and silkworm

Indicator	Laying hens	Mulberry silkworm
<i>USP</i>		
Planting density, number of individuals/m <sup>2</sup>	22	1000
Productivity for 392 days, pcs/m <sup>2</sup>	372,3	8178
Total height and number of cell battery tiers, mm (pcs.)	2550(4)	2550(17)
Output per 1 m <sup>2</sup> of floor area for the whole period in case of tier placement:		
– main raw material: eggs, pcs; cocoon shell, kg	32 762	17 379
– secondary raw materials: pupa, pcs.	–	69 513
<i>DSP</i>		
Purified product yield per unit of raw material, mg	0,030–0,105	0,5–1,8
Yield of purified product from the obtained raw material for the comparable period (392 days), mg	983–3440	34 757–125 124

Note. The purified product yields were calculated based on the data in Table 1.

### *Alternative inoculation and purification methods*

Alternative methods have been developed for inoculation of insect larvae and pupae. A new method of oral infection of silkworms using the cationic reagent lipofectin mixed with viral DNA in an appropriate ratio was created by X. Wu et al.<sup>15</sup> The mixture was applied to silkworm leaves, which were then fed to the larvae. The results showed that at a lipofectin concentration of 0.1 µg/µl, oral infection of silkworms was similar to the traditional inoculation method.

T. Jinn et al.<sup>16</sup> found that recombinant A. californica multiple nucleopolyhedrovirus (AcMN-PV) effectively infects *T. ni* larvae by aerosol inoculation. The method of immersing *T. ni* larvae in a virus-containing solution was equally effective. These results indicated that both the aerosol and immersion routes of infection were via the respiratory tract. The aerosolized AcMN-PV infection pathway was restricted to *T. ni* and *Plutella xylostella* larvae, whereas *Spodoptera litura* and *Helicoverpa armigera* larvae were resistant to this inoculation process. The yields of DsRed and EGFP reporter proteins from *T. ni* larvae after aerosol infection were almost identical to those after oral administration (feeding) or by injection.

When the recombinant *B. mori* baculovirus recombinant baculovirus liquid is sprayed onto the body surface of mulberry silkworm larvae, the virus can also penetrate into the silkworm cells and rapidly infect the insect by peripheral tissue diffusion, eventually realizing total infection<sup>17</sup>.

A method of infecting insect larvae and pupae by soaking in a solution containing baculovirus

was presented in 2010 by a team of authors from China. This method allows to simultaneously treat a large number of larvae, achieve mass infection of larvae or pupae, save labor. The virus penetrates the respiratory tracts of larvae or pupae, infecting them. It has been discovered by chance that stressing the larvae or pupae combined with soaking them provides a more effective infection. The above method of infection has similarly high infection rates and expression levels as the injection method. The infection rates were: injection infection (INJ) 86.3 ± 12.5%, solution soaking (INF) 96.7 ± 3.0%, and expression levels (RFP) 3.3 ± 1.4 and 3.6 ± 1.3 µg/µl, respectively<sup>18</sup>.

### CONCLUSION

A comparative assessment of the key performance indicators of a potential mulberry silkworm-based production platform reveals a number of advantages for the platform:

- 1) raw material versatility of this platform as compared to platforms based on chicken eggs and cabbage looper (allows to obtain and use both primary and secondary raw materials);
- 2) raw material productivity of the platform under consideration is more than 2 times higher compared to platforms based on chicken eggs;
- 3) greater efficiency of raw material used as a bioreactor – with similar methods of purification, the yield of product per unit of raw material in platforms based on mulberry silkworm pupa is about 0.5–1.8 mg against about 0.030–0.105 mg for chicken eggs, which indicates a significant advantage of pupa as a bioreactor for the production of target proteins.

<sup>15</sup>Wu X., Cao C., Kumar V., Cui W. An innovative technique for inoculating recombinant baculovirus into the silkworm *Bombyx mori* using lipofectin // Research in microbiology, 2004, vol. 155, N 6, pp. 462–466.

<sup>16</sup>Jinn T., Kao S., Tseng Y., Chen Y., Wu T. Aerosol infectivity of a Baculovirus to *Trichoplusia ni* larvae: An alternative larval inoculation strategy for recombinant protein production // Biotechnology progress, 2009, vol. 25, N 2, pp. 384–389.

<sup>17</sup><https://patents.google.com/patent/CN102885011A/en>

<sup>18</sup><https://patents.google.com/patent/US20110314562A1/en>

Practical realization of the potential of a *B. mori*-based production platform will comprehensively address the issue of efficient, rapid and large-scale production of vaccines, while ensuring the possibility of their subsequent stabilization and delivery.

## СПИСОК ЛИТЕРАТУРЫ

1. Chen J., Liu Y., Tseng Y., Ma C. Better influenza vaccines: an industry perspective // Journal of biomedical science. 2020. Vol. 27. N 1. P. 33. DOI: 10.1186/s12929-020-0626-6.
2. Nuwarda R., Alharbi A., Kayser V. An Overview of Influenza Viruses and Vaccines // Vaccines. 2021. Vol. 9. N 9. P. 1032. DOI: 10.3390/vaccines9091032.
3. Sparrow E., Wood J., Chadwick C., Newall A., Torvaldsen S., Moen A., Torelli G. Global production capacity of seasonal and pandemic influenza vaccines in 2019 // Vaccine. 2021. Vol. 39. N 3. P. 512–520. DOI: 10.1016/j.vaccine.2020.12.018.
4. Cid R., Bolívar J. Platforms for Production of Protein-Based Vaccines: From Classical to Next-Generation Strategies // Biomolecules. 2021. Vol. 11. N 8. P. 1072. DOI: 10.3390/biom11081072.
5. Akbarian M., Chen S. Instability challenges and stabilization strategies of pharmaceutical proteins // Pharmaceutics. 2022. Vol. 14. N 11. P. 2533. DOI: 10.3390/pharmaceutics14112533.
6. Bajrovic I., Schafer S., Romanovicz D., Croyle M. Novel technology for storage and distribution of live vaccines and other biological medicines at ambient temperature // Science Advances. 2020. Vol. 6. N 10. P. 4819. DOI: 10.1126/sciadv.aau4819.
7. Bajrovic I., Croyle M. Challenges in vaccine transport: can we deliver without the cold chain // Expert Review of Vaccines. 2023. Vol. 22. N 1. P. 933–936. DOI: 10.1080/14760584.2023.2273901.
8. McNulty M., Gleba Y., Tusé D., Hahn Löbmann S., Giritch A., Nandi S., McDonald K. Techno economic analysis of a plant-based platform for manufacturing antimicrobial proteins for food safety // Biotechnology progress. 2020. Vol. 36. N 1. P. 2896. DOI: 10.1002/btpr.2896.
9. Maegawa K., Sugita S., Arasaki Y., Nerome R., Nerome K. Interleukin 12-containing influenza virus-like-particle vaccine elevate its protective activity against heterotypic influenza virus infection // Heliyon. 2020. Vol. 6. N 8. P. 04543. DOI: 10.1016/j.heliyon.2020.
10. Nerome K., Imagawa T., Sugita S., Arasaki Y., Maegawa K., Kawasaki K., Kajiura Z. The potential of a universal influenza virus-like particle vaccine expressing a chimeric cytokine // Life Science Alliance. 2023. Vol. 6. N 1. P. 202201548. DOI: 10.26508/lsa.202201548.
11. Вандышев П.Е. Определение параметров куриных эмбрионов, используемых в производстве инактивированных противогриппозных вакцин // Аграрный научный журнал. 2023. № 5. С. 67–71. DOI: 10.28983/asj.y2023i5pp67-71.
12. Lamberti C., Gai F., Cirrincione S., Giribaldi M., Purrotti M., Manfredi M., Cavallarin L. Investigation of the protein profile of silkworm (*Bombyx mori*) pupae reared on a well-calibrated artificial diet compared to mulberry leaf diet // PeerJ. 2019. Vol. 7. P. 6723. DOI: 10.7717/peerj.6723.
13. Joubrane K., Mnayer D., Hamieh T., Barbour G., Talhouk R., Awad E. Evaluation of quality parameters of white and brown eggs in Lebanon // American Journal of Analytical Chemistry. 2019. Vol. 10. N 10. P. 488–503. DOI: 10.4236/ajac.2019.1010035.
14. Yagi H., Yanaka S., Yogo R., Ikeda A., Onitsuka M., Yamazaki T., Kato K. Silkworm pupae function as efficient producers of recombinant glycoproteins with stable-isotope labeling // Biomolecules. 2020. Vol. 10. N 11. P. 1482. DOI: 10.3390/biom10111482.
15. Xu P., Zhang M., Qian P., Li J., Wang X., Wu Y. ITRAQ-based quantitative proteomic analysis of digestive juice across the first 48 hours of the fifth instar in silkworm larvae // International Journal of Molecular Sciences. 2019. Vol. 20. N 24. P. 6113. DOI: 10.3390/ijms20246113.
16. Holtorf M., Lenaerts C., Cullen D., Vanden Broeck J. Extracellular nutrient digestion and

- absorption in the insect gut // *Cell and Tissue Research*. 2019. Vol. 377. P. 397–414. DOI: 10.1007/s00441-019-03031-9.
17. Stinson J., Palmer C., Miller D., Li A., Lightner K., Jost H., Kosuda K. Thin silk fibroin films as a dried format for temperature stabilization of inactivated polio vaccine // *Vaccine*. 2020. Vol. 38. N 7. P. 1652–1660. DOI: 10.1016/j.vaccine.2019.12.062.
18. Stinson J., Boopathy A., Cieslewicz B., Zhang Y., Hartman N., Miller D., Kosuda K. Enhancing influenza vaccine immunogenicity and efficacy through infection mimicry using silk microneedles // *Vaccine*. 2021. Vol. 39. N 38. P. 5410–5421. DOI: 10.1016/j.vaccine.2021.07.064.
19. Юматов Е.Н., Евлагина Е.Г., Евлагин В.Г., Лейнвебер Е.Ф., Товнеко Д.В., Дебенюк С.С. Возможности биотехнологической платформы тутового шелкопряда (*B. mori*) для регенеративной медицины // *Регенерация органов и тканей*. 2024. Т. 1. № 2. С. 33–54. DOI: 10.60043/2949-5938-2023-2-33-54.
20. Астраханцев А.А. Показатели яйценоскости кур при содержании в клетках с различными параметрами посадки // *Птицеводство*. 2021. № 1. С. 34–37. DOI: 10.33845/0033-3239-2021-70-1-34-37.
21. Евлагин В.Г., Евлагина Е.Г., Лейнвебер Е.Ф., Юматов Е.Н. Динамика развития гусениц тутового шелкопряда пород Кавказ-2 и Советская-14 НГЛ на искусственной питательной среде ИПС 7.2-Г // *Амурский зоологический журнал*. 2023. Т. 15. № 4. С. 870–880. DOI: 10.33910/2686-9519-2023-15-4-870-880.
22. Escribano J., Cid M., Reytor E., Alvarado C., Nuñez M., Martínez-Pulgarín S., Dalton R. Chrysalises as natural production units for recombinant subunit vaccines // *Journal of Biotechnology*. 2020. Vol. 324. P. 100019. DOI: 10.1016/j.btecx.2020.100019.
23. Falcón A., Martínez-Pulgarín S., López-Serrano S., Reytor E., Cid M., Nuñez M., Escribano J. Development of a Fully Protective Pandemic Avian Influenza Subunit Vaccine in Insect Pupae // *Viruses*. 2024. Vol. 16. N 6. P. 829. DOI: 10.3390/v16060829.

## REFERENCES

1. Chen J., Liu Y., Tseng Y., Ma C. Better Influenza Vaccines: An Industry Perspective. *Journal of biomedical science*, 2020, vol. 27, no. 1, p. 33. DOI: 10.1186/s12929-020-0626-6.
2. Nuwarda R., Alharbi A., Kayser V. An Overview of Influenza Viruses and Vaccines. *Vaccines*, 2021, vol. 9, no. 9, p. 1032. DOI: 10.3390/vaccines9091032.
3. Sparrow E., Wood J., Chadwick C., Newall A., Torvaldsen S., Moen A., Torelli G. Global Production Capacity of Seasonal and Pandemic Influenza Vaccines in 2019. *Vaccine*, 2021, vol. 39, no. 3, pp. 512–520. DOI: 10.1016/j.vaccine.2020.12.018.
4. Cid R., Bolívar J. Platforms for Production of Protein-Based Vaccines: From Classical to Next-Generation Strategies. *Biomolecules*, 2021, vol. 11, no. 8, p. 1072. DOI: 10.3390/biom11081072.
5. Akbarian M., Chen S. Instability Challenges and Stabilization Strategies of Pharmaceutical Proteins. *Pharmaceutics*, 2022, vol. 14, no. 11, p. 2533. DOI: 10.3390/pharmaceutics14112533.
6. Bajrovic I., Schafer S., Romanovicz D., Croyle M. Novel Technology for Storage and Distribution of Live Vaccines and Other Biological Medicines at Ambient Temperature. *Science advances*, 2020, vol. 6, no. 10, p. 4819. DOI: 10.1126/sciadv.aau4819.
7. Bajrovic I., Croyle M. Challenges in Vaccine Transport: Can We Deliver Without the Cold Chain. *Expert review of vaccines*, 2023, vol. 22, no. 1, pp. 933–936. DOI: 10.1080/14760584.2023.2273901.
8. McNulty M., Gleba Y., Tusé D., Hahn Löbmann S., Giritch A., Nandi S., McDonald K. Techno-Economic Analysis of a Plant-Based Platform for Manufacturing Antimicrobial Proteins for Food Safety. *Biotechnology progress*, 2020, vol. 36, no. 1, p. 2896. DOI: 10.1002/btpr.2896.
9. Maegawa K., Sugita S., Arasaki Y., Nerome R., Nerome K. Interleukin 12-Containing Influenza Virus-Like-Particle Vaccine Elevate Its Protective Activity Against Heterotypic Influenza Virus

- Infection. *Heliyon*, 2020, vol. 6, no. 8. P. 04543. DOI: 10.1016/j.heliyon.2020.
10. Nerome K., Imagawa T., Sugita S., Arasaki Y., Maegawa K., Kawasaki K., Kajiura Z. The Potential of a Universal Influenza Virus-Like Particle Vaccine Expressing a Chimeric Cytokine. *Life science alliance*, 2023, vol. 6, no. 1, p. 202201548. DOI: 10.26508/lsa.202201548.
  11. Vandyshv P.E. Determination of parameters of chick embryos used in the production of inactivated influenza vaccines. *Agrarniy nauchniy zhurnal = Agrarian Scientific Journal*, 2023, no. 5, pp. 67–71. (In Russian). DOI: 10.28983/asj.y2023i5pp67-71.
  12. Lamberti C., Gai F., Cirrincione S., Giribaldi M., Purrotti M., Manfredi M., Cavallarin L. Investigation of the Protein Profile of Silkworm (*Bombyx mori*) Pupae Reared on a Well-Calibrated Artificial Diet Compared to Mulberry Leaf Diet. *PeerJ*, 2019, vol. 7, p. 6723. DOI: 10.7717/peerj.6723.
  13. Joubrane K., Mnayer D., Hamieh T., Barbour G., Talhouk R., Awad E. Evaluation of Quality Parameters of White and Brown Eggs in Lebanon. *American Journal of Analytical Chemistry*, 2019, vol. 10, no. 10, pp. 488–503. DOI: 10.4236/ajac.2019.1010035.
  14. Yagi H., Yanaka S., Yogo R., Ikeda A., Onitsuka M., Yamazaki T., Kato K. Silkworm Pupae Function as Efficient Producers of Recombinant Glycoproteins with Stable-Isotope Labeling. *Biomolecules*, 2020, vol. 10, no. 11, p. 1482. DOI: 10.3390/biom10111482.
  15. Xu P., Zhang M., Qian P., Li J., Wang X., Wu Y. ITRAQ-Based Quantitative Proteomic Analysis of Digestive Juice Across the First 48 Hours of the Fifth Instar in Silkworm Larvae. *International journal of molecular sciences*, 2019, vol. 20, no. 24, p. 6113. DOI: 10.3390/ijms20246113.
  16. Holtof M., Lenaerts C., Cullen D., Vanden Broeck J. Extracellular Nutrient Digestion and Absorption in the Insect Gut. *Cell and tissue research*, 2019, vol. 377, no. 3, pp. 397–414. DOI: 10.1007/s00441-019-03031-9.
  17. Stinson J., Palmer C., Miller D., Li A., Lightner K., Jost H., Kosuda K. Thin Silk Fibroin Films as a Dried Format for Temperature Stabilization of Inactivated Polio Vaccine. *Vaccine*, 2020, vol. 38, no. 7, pp. 1652–1666. DOI: 10.1016/j.vaccine.2019.12.062.
  18. Stinson J., Boopathy A., Cieslewicz B., Zhang Y., Hartman N., Miller D., Kosuda K. Enhancing Influenza Vaccine Immunogenicity and Efficacy Through Infection Mimicry Using Silk Microneedles. *Vaccine*, 2021, vol. 39, no. 38, pp. 5410–5421. DOI: 10.1016/j.vaccine.2021.07.064.
  19. Yumatov E.N., Evlagina E.G., Evlagin V.G., Leinweber E.F., Tovpeko D.V., Debenok S.S. Possibilities of *Bombyx mori* (*B. mori*) biotechnological platform for regenerative medicine. *Regeneratsiya organov i tkaney = Tissue and organ regeneration*, 2024, vol. 1, no. 2, pp. 33–54. (In Russian). DOI: 10.60043/2949-5938-2023-2-33-54.
  20. Astrakhantsev A.A. The productive performance in indicators of hens kept in cages with different stocking parameters. *Ptitsevodstvo = Poultry farming*, 2021, vol. 1, pp. 34–37. (In Russian). DOI: 10.33845/0033-3239-2021-70-1-34-37.
  21. Evlagin V.G., Evlagina E.G., Leinweber E.F., Yumatov E.N. Development Dynamics of Kavkaz-2 and Sovetskaya-14 NGL Silkworm Caterpillars on Artificial Nutrient Medium IPS 7.2-G. *Amurskiy zoologicheskii zhurnal = Amurian Zoological Journal*, 2023, vol. 15, no. 4, pp. 870–880. (In Russian). DOI: 10.33910/2686-9519-2023-15-4-870-880.
  22. Escribano J., Cid M., Reytor E., Alvarado C., Nuñez M., Martínez-Pulgarín S., Dalton R. Chrysalises as Natural Production Units for Recombinant Subunit Vaccines. *Journal of biotechnology*, 2020, vol. 324, p. 100019. DOI: 10.1016/j.btex.2020.100019.
  23. Falcón A., Martínez-Pulgarín S., López-Serrano S., Reytor E., Cid M., Nuñez M., Escribano J. Development of a Fully Protective Pandemic Avian Influenza Subunit Vaccine in Insect Pupae. *Viruses*, 2024, vol. 16, no. 6, p. 829. DOI: 10.3390/v16060829.

## ИНФОРМАЦИЯ ОБ АВТОРАХ

✉ **Юматов Е.Н.**, индивидуальный предприниматель, научный сотрудник; **адрес для переписки:** Россия, 443122, Самара, ул. Московское шоссе, 294, кв. 32; e-mail: trast1207@mail.ru

**Евлагина Е.Г.**, директор Научно-исследовательской станции шелководства

**Евлагин В.Г.**, научный сотрудник

**Лейнвебер Е.Ф.**, кандидат сельскохозяйственных наук, старший научный сотрудник

## AUTHOR INFORMATION

✉ **Evgeny N. Yumatov**, Sole Entrepreneur, Researcher; **address:** Apart. 32, 294, Moskovskoe shosse st., Samara, 443122, Russia; e-mail: trast1207@mail.ru

**Elena G. Evlagina**, Director of the RS of Sericulture

**Viktor G. Evlagin**, Researcher

**Evdokia F. Leinweber**, Candidate of Science in Agriculture, Senior Researcher

*Дата поступления статьи / Received by the editors 09.08.2024*

*Дата принятия к публикации / Accepted for publication 11.09.2024*

*Дата публикации / Published 20.11.2024*

## Мука из насекомых как альтернативный кормовой ингредиент в рационе сельскохозяйственных животных

✉ Лукьянчикова Н.Л., Цимбалова Т.А., Андреева И.В., Шаталова Е.И., Рогачев В.А.

*Siberian Federal Scientific Centre of Agro-BioTechnologies of the Russian Academy of Sciences*  
Новосибирская область, р.п. Краснообск, Россия

✉ e-mail: lukyanchikovanl@sfsca.ru

Представлены результаты исследования новых кормовых средств для сельскохозяйственных животных. В связи с сокращением производства рыбной муки в России, а также нестабильным качеством коммерческой муки животного происхождения, которая традиционно используется как источник полноценного белка, обменной энергии и макроэлементов в рационе домашней птицы, свиней, аквакультуры, актуальным стал вопрос поиска альтернативных кормовых ингредиентов. Изучен вопрос о возможности замены рыбной и мясокостной муки на муку из промышленно культивируемых насекомых. Изучен биохимический состав кормовой муки из насекомых различных отрядов (Diptera, Orthoptera, Coleoptera, Blattodea), перспективных для промышленного культивирования. Благодаря высокому содержанию сырого жира и сырого протеина обменная энергия в данном продукте, определенная для птиц и свиней, имела более высокие значения (16,4–21,60 МДж/кг), чем в исследованных образцах коммерческой рыбной и мясокостной муки отечественных производителей (13,7–18,73 МДж/кг). Содержание сырого протеина в муке из насекомых разных отрядов имело значение от 45 до 87%, при этом доля переваримого пепсином протеина составляла 59,2–87,6%. Абсолютное количество переваримого пепсином протеина в обезжиренной муке из исследованных видов насекомых составило 45,8–61,0 г/100 г и было сопоставимо со значениями, полученными для обезжиренной рыбной (43,9–72 г/100 г) и мясокостной муки (34,8–68,3 г/100 г) разных производителей. По содержанию макроэлементов (кальция и фосфора) продукт значительно уступал рыбной и мясокостной муке. Также в муке из насекомых отмечено значительное количество хитина (4,1–7,2%), что может оказать существенное влияние на кормовую ценность продукта.

**Ключевые слова:** промышленно культивируемые насекомые, мука из насекомых, обменная энергия, кормовая ценность, сырой протеин, переваримый протеин, хитин

## Insect meal as an alternative feed ingredient in the diet of farm animals

✉ Lukyanchikova N.L., Tsimbalova T.A., Andreeva I.V., Shatalova E.I., Rogachev V.A.

*Siberian Federal Scientific Centre of Agro-BioTechnologies of the Russian Academy of Sciences*  
Krasnoobsk, Novosibirsk region, Russia

✉ e-mail: lukyanchikovanl@sfsca.ru

The results of research on new feeding products for farm animals are presented. Due to the reduction of fish meal production in Russia, as well as the unstable quality of commercial fish meal of animal origin, which is traditionally used as a source of complete protein, metabolizable energy and macronutrients in the diet of poultry, pigs, aquaculture, the issue of searching for alternative feed ingredients has become relevant. The possibility of replacing fish and meat and bone meal with meal from industrially cultured insects has been studied. The biochemical composition of feed meal from insects of different orders (Diptera, Orthoptera, Coleoptera, Blattodea) promising for industrial cultivation has been studied. Due to the high content of crude fat and crude protein, the metabolizable energy in this product, determined for poultry and pigs, had higher values (16.4–21.60 MJ/kg) than in the studied samples of commercial fish and meat and bone meal of domestic producers (13.7–18.73 MJ/kg). The crude protein content of insect meal from different insect orders had the values ranging from 45 to 87%, with the proportion of pepsin digestible protein ranging from 59.2–87.6%. The absolute amount of pepsin digestible protein in defatted meal from the insect species studied was 45.8–61.0 g/100 g and was comparable to the values obtained for defatted fish meal (43.9–72 g/100 g) and meat and bone meal (34.8–68.3) from different producers. At the same time, the content of macronutrients (calcium and phosphorus) of the product was significantly inferior to fish and meat and bone meal. Also, insect

meal had a significant amount of chitin (4.1–7.2%), which may have a significant impact on the feed value of the product.

**Keyword:** industrially cultivated insects, insect meal, metabolic energy, feed value, crude protein, digestible protein, chitin

**Для цитирования:** Лукьянчикова Н.Л., Цимбалова Т.А., Андреева И.В., Шаталова Е.И., Рогачев В.А. Мука из насекомых как альтернативный кормовой ингредиент в рационе сельскохозяйственных животных // Сибирский вестник сельскохозяйственной науки. 2024. Т. 54. № 10. С. 108–117. <https://doi.org/10.26898/0370-8799-2024-10-11>

**For citation:** Lukuanchikova N.L., Tsimbalova T.A., Andreeva I.V., Shatalova E.I., Rogachev V.A. Insect meal as an alternative feed ingredient in the diet of farm animals. *Sibirskii vestnik sel'skokhozyaistvennoi nauki = Siberian Herald of Agricultural Science*, 2024, vol. 54, no. 10, pp. 108–117. <https://doi.org/10.26898/0370-8799-2024-10-11>

#### Конфликт интересов

Авторы заявляют об отсутствии конфликта интересов.

#### Conflict of interest

The authors declare no conflict of interest.

#### Благодарность

Работа выполнена при финансовой поддержке FNUU-2022-0008.

#### Acknowledgments

The work was performed with the financial support of the FNUU-2022-0008.

## INTRODUCTION

Currently, in global practice, it is an undeniable fact that industrially cultivated insects are used as raw materials for producing feed and food protein<sup>1</sup> [1, 2]. This direction of practical activity is relevant due to the shortage of animal protein and the search for alternative sources of this valuable component in animal diets and human nutrition. In the Russian Federation, this issue is particularly acute in the production of feed for aquaculture. Currently, the production of feed for valuable fish species accounts for 10–15% of the imported volume, but there is a significant shortage of this product in the domestic market [1].

Industrial insect cultivation has several advantages over traditional livestock farming. These include: a lower feed conversion ratio for insects compared to all types of farm animals (cattle, pigs, poultry); the ability to use organic

waste (food waste, as well as waste from milling, brewing, meat, and winemaking industries) for the industrial cultivation of insects—such as black soldier fly, cricket, mealworm, housefly, and others. Overall, their production is associated with lower land and water resource consumption and minimized negative environmental impacts<sup>2–4</sup> [2–5].

Insects are characterized by a high content of complete protein, fat, minerals, vitamins, biologically active substances, insect protein composition is characterized by a high content of essential amino acids (see footnote 3). According to literature data, the amino acid composition of Diptera insect larvae (which includes the black soldier fly) is the best substitute for fishmeal for aquaculture compared to insects of other insect groups [6].

Positive results have been obtained in experiments on partial replacement of fish meal with

<sup>1</sup>Van Huis A. Potential of insects as food and feed in assuring food security // Annual Review of Entomology, 2013, vol. 58, pp. 563–583. DOI: 10.1146/annurev-ento-120811-153704.

<sup>2</sup>Oonincx D.G.A.B., Van Broekhoven S., Van Huis A., Van Loon J.J.A. Feed conversion, survival and development, and composition of four insect species on diets composed of food by-products // PLoS ONE, 2015, N 10 (12), P. e0144601. DOI: 10.1371/journal.pone.0144601.

<sup>3</sup>Sánchez-Muros M.J., Barroso F.G., de Haro C. Brief summary of insect usage as an industrial animal feed // Feed Ingredient, 2016, pp. 273–309. DOI: 10.1016/B978-0-12-802856-8.00010-7.

<sup>4</sup>Wang Y.-S., Shelomi M. Review of black soldier fly (*Hermetia illucens*) as animal feed and human food // Foods, 2017, N 6 (10), p. 91. DOI: 10.3390/foods6100091.

insect meal in the feeding of pigs [7], quails [8], turkeys [9], chickens [10], partridges<sup>5</sup>, aquaculture [6].

Currently, the company Novye Biotechnologii<sup>6</sup> (Lipetsk) is producing feed protein from fly larvae of the *Lucilia caesar* population by processing shredded meat waste. The company InAgroBio (Yaroslavl Region), specializing in aquaculture, breeds house flies (*Musca domestica*) to provide fry with fodder of its own production<sup>7</sup>. Animal feed protein based on black soldier flies is produced by Biogenesis (Moscow)<sup>8</sup>, Entoprotek LLC (International Biotechnology Company), EcoBelok (Moscow), NordTekhSad (Arkhangelsk).

In accordance with GOST 70269-2022<sup>9</sup>, the Kjeldahl method is recommended for estimating the crude protein content of insect flour, using a nitrogen-to-protein conversion factor of 6.25. The exoskeleton of insects is known to contain chitin, which is a nitrogen-containing polysaccharide (with an estimated nitrogen content of 7.22%). Therefore, this method gives overestimates, with the error being greater the higher the chitin content of a particular species. In addition, some insect proteins are firmly embedded in the chitin matrix and are not digested in the digestive tract of animals<sup>10</sup>. Therefore, for an objective assessment of the feed value of insect meal, it is necessary to determine the amount of protein digested by pepsin in the raw material under study.

Other substances contained in the products obtained from insects are also of practical value. Chitin and its derivative—chitosan, fatty acid complex, organic forms of mineral substances,

melanins, antimicrobial peptides, hormones, etc.<sup>11</sup> [3, 4, 11-12] are in demand on the world market. A valuable product is fat extracted from insect biomass during their processing [13].

The purpose of the research is to study the biochemical composition of insect meal from different insect species, promising for industrial production, and to compare it with traditional sources of animal protein, included in the composition of feeds for farm animals and aquaculture – fish and meat-bone meal.

## MATERIAL AND METHODS

The objects of the study were laboratory cultures of insects: black soldier fly *Hermetia illucens* L. (Diptera), house cricket *Acheta domestica* L. (Orthoptera), yellow mealworm beetle *Tenebrio molitor* L. and zophobas *Zophobas molitor* Fabr. (Coleoptera), marbled *Nauphoeta cinerea* Oliver and black *Rusopocellus nigra* Brun. cockroaches (Blattodea). Populations of these insects are maintained in the laboratory of biological control of phytophages and phytopathogens at the Siberian Federal Scientific Centre of Agro-BioTechnologies of the Russian Academy of Sciences. The stages of the insect life cycle (larvae of the black lionfly, zophobas, yellow mealworm beetle and adult forms of the house cricket, black and marbled cockroaches), at which they reached their maximum mass, were used as a source of feed protein.

Populations of black and marbled cockroaches and house crickets were kept in laboratory conditions on a fruit and vegetable diet with the addition of protein feed used in poultry and live-

<sup>5</sup>Seccia G., Moniello G., Gascoc L., Boverad F., Parisia G. Barbary partridge meat quality as affected by *Hermetia illucens* and *Tenebrio molitor* larva meals in feeds // Food Research International, 2018, vol. 112, pp. 291–298. DOI: 10.1016/j.foodres.2018.06.04.

<sup>6</sup>Processing of organic agricultural waste by fly larvae to produce protein for animals, poultry and fish, and to produce organic fertilizers. URL: <https://www.zooprotein.com/>

<sup>7</sup>Protein of the XXI century: crickets, cockroaches and fly larvae. URL: <https://agrarii.com/protein-xxi-veka-sverchki-tarakanyi-lichinki-muh>

<sup>8</sup>Patent 654 220 C1. Babaev N.A., Bastrakov A.I., Sokolov I.V. Method of processing organic waste by fly larvae *Hermetia illucens* with obtaining protein of animal origin and biohumus. 2017.

<sup>9</sup>GOST 70269-2022 Biotechnology. Fodder flour from insect biomass. Technical conditions. Moscow, Russian Institute of Standardization, 2022, 8 p.

<sup>10</sup>Jonas-Levi A., Martinez J.-J. I. The high level of protein content reported in insects for food and feed is overestimated // Journal of Food Composition and Analysis, 2017, N 62, pp. 184–188. DOI: 10.1016/j.jfca.2017.06.004.

<sup>11</sup>Wang Y.-S., Shelomi M. Review of Black Soldier Fly (*Hermetia illucens*) as Animal Feed and Human Food // Foods, 2017, vol. 6 (10), p. 91. <https://doi.org/10.3390/foods6100091>.

stock production. Wheat bran was used as a substrate and the main feed component for larvae of the yellow mealworm beetle and *Zophobas*, and juicy food (carrots, potatoes) was given twice a week to maintain water balance and vitaminization. The larvae were reared to marketable products, i.e., to an older age, after which they were used for experiments.

The technology of semi-industrial production of forage black soldier fly and maintenance of breeding stock included two stages: keeping adults and obtaining eggs; keeping larvae and obtaining pupae. Adults were kept in mesh insectaries at temperatures ranging from +27 to +31 °C under 24-hour illumination (a 4000 K daylight lamp was used). Black soldier fly eggs were placed in a substrate (wheat bran with 70% humidity) and transferred to a larvarium where air temperature was maintained from +20 to +22 °C. Larvae intended for feeding purposes, when they reached the age of 3 weeks were sieved on a vibrating screen with a cell size of 3 mm, then washed with warm water and used for experiments. Soldier fly larvae intended for maternal stock were continued to be fed until pupation in order to obtain adults of the next generation.

The studied insects, kept one day on starvation and subjected to rapid freezing at -20 °C, in an amount of at least 200 g were dried on a household microwave oven with a power of 800 W for 10 min. The dried insects were ground on a laboratory mill, after which the biochemical parameters of the obtained meal were examined and compared with the samples of commercial fish and meat-bone meal from different domestic manufacturers.

The average sample from black soldier fly

flour was prepared in accordance with GOST 70269-2022, from fish flour – in accordance with GOST 13496.0-2016<sup>12</sup>. The mass of the sample from which the average sample was prepared was 2.5 kg for flour from black soldier fly larvae, 500 g for flour from insects of other species, and at least 2.5 kg for fish meal. All biochemical tests were performed in duplicates according to GOST recommendations. The arithmetic mean of measurements was taken as the final result.

Crude protein was determined in accordance with GOST P 70269-22 by the Kjeldahl method. The content of crude fat, crude fiber (chitin), moisture, crude ash was determined according to GOST R 70269-2022, calcium – according to GOST 32343-2013<sup>13</sup> and phosphorus – according to GOST 51420-99<sup>14</sup>. Pepsin digestible protein was determined in accordance with GOST P 51423-99<sup>15</sup>.

Nitrogen-free extractive substances (NES) were calculated according to the formula

$$\text{NES} = 100 - \text{H} - \text{CP} - \text{CF} - \text{CFb} - \text{C3}. \quad (1)$$

where ME – metabolic energy, MJ/kg; H – humidity, %; CP – crude protein, %; CF – crude fat, %; CFb – crude fiber, %; CA – crude ash, %.

The metabolic energy was calculated in 1 MJ for 1 kg of feed according to the formulas<sup>16</sup>:

$$\text{For birds ME} = (331,53 + 1,002 \times \text{CP} + 3,855 \times \text{CF} - 3,315 \times \text{CA}) / 23,88, \quad (2)$$

$$\text{For pigs ME} = (331,53 + 1,002 \times \text{CP} + 3,855 \times \text{CF} - 3,315 \times \text{CFb} - 3,315 \times \text{CA}) \times 0,042. \quad (3)$$

To determine digestible protein, insect meal, as well as fish and meat and bone meal obtained by the method described above were degreased on a Soxtec (Foss) fat analyzer with petroleum ether with a boiling point of 40–70 °C for 6–8 h

<sup>12</sup>GOST 13496.0-2016. Feeds, mixed fodder. Methods of sampling. Moscow: Standardinform, 2016, 14 p.

<sup>13</sup>GOST 32343-2013. Feed, mixed fodder. Determination of calcium, copper, iron, magnesium, potassium, sodium and zinc by atomic absorption spectroscopy. Moscow: Standardinform, 2020, 16 p.

<sup>14</sup>GOST 51420-99. Fodders, mixed fodders, mixed fodder raw materials. Spectrometric method for determining the mass fraction of phosphorus. Moscow: Standardinform, 2020, 6 p.

<sup>15</sup>GOST R 51423-99. Fodder, mixed fodder, mixed fodder raw material. Method for determining the mass fraction of soluble nitrogen after treatment with pepsin in dilute hydrochloric acid. Moscow: Standardinform, 2020.

<sup>16</sup>Methodology of calculation of metabolizable energy in forages based on the content of crude nutrients (for cattle, sheep and pigs) / M.P. Kirillov, E.A. Makhaev, N.G. Pervov, V.V. Puzanova, A.S. Anikin / Dubrovitsy: Ministry of Agriculture of the Russian Federation RAS VNIIZh, 2008. <http://meganorm.ru/Data/1/4293764645.htm>

and dried at room temperature (see the figure). Then the obtained product was hydrolyzed with pepsin (porcine whey pepsin with enzymatic activity of more than 1.5 million units) in 0.075 M hydrochloric acid, pH 1.3, and the crude protein in the hydrolysate and the mass fraction of crude protein in the initial product were determined.

## RESULTS AND DISCUSSION

According to the data obtained, the amount of crude protein, determined in accordance with the Kjeldahl method, in dry flour for different insect species was from 45.0 to 87.4% (see Table 1). The highest amount of crude protein was found in the flour of the black cockroach (87.4%), a little less in the flour from adult crickets (64.18%) and marbled cockroach (62.05%), in the flour from the larvae of the black soldier fly, yellow mealworm beetle and *Zophobas* its content varied from 45.00 to 48.13%. It should be noted that in the samples of fish and meat and bone meal from different producers, there was also a very large variation of this indicator: in fish meal the values ranged from 44.8 to 69.8%, in meat and bone meal – from 50.0 to 64.37% (see Table 1).

Insect flour is characterized by high fat content: the highest amount of crude fat was obtained from the flour of black soldier flies, *Zophobas* and yellow mealworm beetle and ranged from 32 to 40%, which is undesirable in the

composition of feed mixtures for certain animal species, in particular for fish [14], and implies the procedure of degreasing the product.

At the same time, the sum of insect flour components determined in accordance with GOST R 70269-2022 (humidity, crude fiber, crude protein, crude ash, crude fat) may exceed 100%, since fiber (chitin) in insect flour is counted twice: when crude protein is determined by the Kjeldahl method and when crude fiber is determined by the gravimetric method (as in the case of black cockroach flour, see Table 1).

To obtain objective indices of protein content, we determined the amount of pepsin-digestible protein in defatted insect meal, as well as in defatted fish and meat-bone meal (see Table 2). The digestible protein content in insect meal was 56.0–66.8 g/100 g in absolute values, while in different samples of fish meal these values ranged from 43.9 to 72%, in meat and bone meal – from 34.8 to 68.3% depending on the batch and manufacturer (see Table 2). According to the content of digestible protein in relation to crude protein, the best values were observed in the black soldier fly (85%), yellow mealworm beetle (87.6%), house cricket (79.1%) and *Zophobas* (82.5%), the lowest values were observed in the flour of black and especially marbled cockroaches (64.2 and 59.2%, respectively). Taking into account that the content of crude chitin in flour from marbled and black cockroaches is not



Схема получения обезжиренной муки из насекомых  
Scheme for the production of defatted insect meal

**Табл. 1.** Биохимический состав муки из насекомых по сравнению с различными образцами рыбной и мясокостной муки**Table 1.** Biochemical composition of insect meal compared to various samples of fish and meat and bone meal

Object of study	Moisture content, %	Crude protein, %	Crude fat, %	Crude chitin (fiber), %	Crude ash, %	Nitrogen-free extractive substances, %	Calcium, %	Phosphorus, %	Ca/P	ME for pigs, MJ/kg	ME for birds, MJ/kg
Black soldier fly (larva)	6,77	46,60	32,0	4,1	7,70	2,83	0,4	0,77	0,52	19,22	19,02
Zophobas (larva)	5,00	45,00	40,0	3,8	4,00	2,20	0,36	0,84	0,57	21,10	20,83
House cricket	15,00	64,18	10,40	5,14	4,24	1,04	0,35	0,63	0,56	16,40	16,7
Black beetle	5,90	87,40	17,70	5,78	3,72	-20,5*	0,60	0,63	0,95	18,95	18,3
Marbled cockroach	6,75	62,05	9,67	7,2	3,90	10,43	0,31	0,61	0,51	18,88	18,5
Yellow mealworm beetle	6,62	48,13	32,30	4,4	3,10	5,45	0,26	0,56	0,46	19,77	19,22
Fish flour (ЗАО «Росветфарм»)	5,20	61,40	10,00	0,6	17,5	5,3	5,1	3,75	1,36	15,61	15,56
Fish flour (Vladivostok)	5,24	69,80	9,20	0,6	14,20	0,96	4,1	2,79	1,47	13,70	18,58
Fish flour 1 (ООО Vector, Barnaul)	6,90	44,80	16,70	0,72	27,80	3,08	5,1	3,38	1,51	13,69	14,50
Fish flour 2 (ООО Vector, Barnaul)	4,0	58,20	10,00	0,72	23,00	4,08	4,7	3,18	1,48	14,44	14,65
Feed meal of animal origin, 1st grade (according to GOST 17536-82)	9,0	50,00	13,00	2,00	26,00	0,0	10,1	7,57	1,33	13,83	14,19
Meat and bone flour, "Biotech" enterprise	4,62	64,37	14,15	1,2	15,37	0,29	4,5	3,09	1,46	18,72	16,57

\*The negative value of nitrogen-free extractive substances determined by formula (1) is due to the fact that chitin is a nitrogen-containing compound and is accounted for twice in the formula: as fiber and as crude protein determined by the Kjeldahl method.

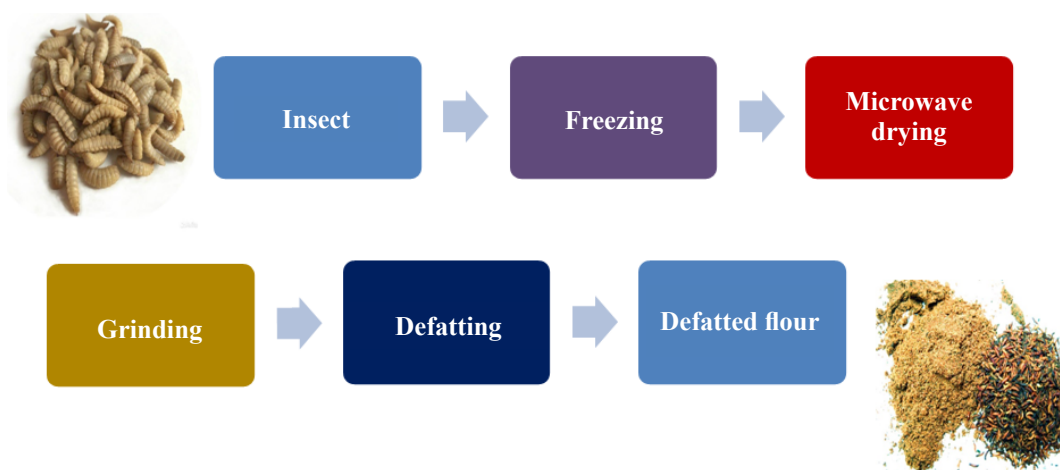
higher than in flour from other insects studied, it can be assumed that cockroaches have a rather high content of protein firmly embedded in the chitin matrix, which is not broken down by digestive enzymes.

In terms of absolute values, the content of digestible protein in defatted insect meal is comparable to the best samples of fish and meat-bone meal (see Table 2).

The content of mineral elements in feeds<sup>17</sup> is important for a balanced fodder ration of productive animals, in connection with which there is a need to assess these indicators in primary raw materials in the production of feeds for spe-

cific animal species. Thus, the component composition of mixed fodders for pond carp fishes, as a rule, is depleted of mineral elements, or they are in a form inaccessible for digestion by fish enzymes. Natural food (plankton, insects, underwater vegetation, etc.) contains all necessary elements in physiologically agreed ratios in accordance with the salt composition of water, and therefore it is an important supplement, leveling the shortcomings of the mineral part of mixed fodders<sup>18</sup>.

According to our data (see Table 1), the amount of calcium and phosphorus in the samples of insect meal differed insignificantly, but

<sup>17</sup>Medvedsky V.A., Bazylev M.V., Bolshakova L.P., Munayar H.F. Biological basis of mineral nutrition of poultry // Scientific Review. Biological Sciences, 2016, N 2, pp. 93-108.

<sup>18</sup>Nutrient requirements of fish: mineral elements. URL: <http://www.aquaristics.ru/pond/forage/potrebnoost-ryb-v-pitatelnyh-veschestvah-mineralnye-elementy>

**Табл. 2.** Содержание сырого и переваримого протеина в обезжиренной муке из насекомых по сравнению с различными образцами обезжиренной рыбной и мясокостной муки, %

**Table 2.** Crude and digestible protein content of defatted insect meal compared to different samples of defatted fish and meat-bone meal, %

Object of study (defatted flour)	Crude protein	Pepsin-digestible protein	Proportion of protein digested by pepsin in relation to crude protein	Crude fiber (chitin)
Black soldier fly (larva)	65,9	56,0	85,0	7,8
Zophobas (larva)	65,6	54,1	82,5	8,7
House cricket	77,51	61,0	79,1	5,6
Black beetle	91,1	58,5	64,2	7,8
Marbled cockroach	77,33	45,8	59,2	7,7
Yellow mealworm beetle	71,1	62,3	87,6	8,7
Fish flour (ЗАО «Росветфарм»)	68,2	66,8	98,0	0,7
Fish flour (Владивосток)	72,19	72,0	99,7	0,7
Fish flour 1 (ООО «Вектор», Барнаул)	44,8	43,9	98,0	0,83
Fish flour 2 (ООО «Вектор», Барнаул)	58,2	56,45	97,0	0,8
Feed meal of animal origin, 1st grade (according to GOST 17536-82)	57,4	50,5	88,0	2,3
Meat and bone meal (poultry), "Biotech" enterprise	78,5	68,3	87	2,0
Meat and bone meal (ZАО "Rosvetfarm")	44,53	34,8	78,1	2,0

in general was significantly inferior to fish and meat-bone meal. At the same time, the calcium/phosphorus ratio in insect meal was less than one, which does not correspond to the optimal values (1.1–1.4 for fish, 2.15–2.25 for poultry and 1.3 for pigs), while in fish and meat and bone meal samples this ratio was optimal (see Table 1).

In terms of metabolizable energy levels calculated from crude nutrients for both pigs and poultry, flours derived from all insect species exceed this value for commercial fish and meat and bone meal samples (see Table 1).

The obtained results indicate that, taking into account the limited resource of fish products,

insects are a promising alternative source of animal protein for feeding productive animals. However, when rationing this product in diets, it is necessary to take into account the high content of chitin in whole insect meal and take into account the share of digestible protein, as well as to correct the content of calcium and phosphorus with the help of mineral supplements. Reliable assessment of insect meal fodder qualities can be made only after its research on animals with the study of the quality of the obtained food products, their cost and profitability.

## CONCLUSIONS

1. The metabolizable energy of insect flour from six studied insects of different groups, cal-

culated by crude matter, exceeds the values of metabolizable energy calculated for different samples of fish and meat and bone meal, which is due to the higher content of crude fat and crude protein in insect flour. The exchangeable energy of insect meal of different species calculated for birds was 16.7–20.83 MJ/kg, for pigs it was 18.88–21.10 MJ/kg, while the values for fish and meat and bone meal were in the range of 13.7–18.72 MJ/kg.

2. The proportion of protein digested by pepsin in relation to crude protein in insect meal from the studied insect species is 59.2–87.6%, which is less than in fish meal (98–99%), but is at the level of values for meat and bone meal. By the absolute amount of digestible protein (grams per 100 g of feed), all samples of insect meal are comparable to the best samples of both fish and meat-bone meal.

3. The crude fiber content in insect meal is significantly higher than in all samples of fish and meat and bone meal due to the presence of chitin and is 4.10–7.2%.

4. The content of calcium and phosphorus in insect meal is significantly inferior to the indicators obtained for fish and meat-bone meal. At the same time, the ratio of calcium and phosphorus in all species of insects is less than unity with optimal values for feeds 1,00–2,25.

## СПИСОК ЛИТЕРАТУРЫ

1. Павлович Г., Лебедев В., Кузьмин И. Актуальность производства белка из биомассы личинок для товарной аквакультуры // Комбикорма. 2021. Т. 5. С. 12–14.
2. Govorushko S. Global status of insects as food and feed source: A review // Trends in Food Science & Technology. 2019. Vol. 91. P. 436–445. DOI: 10.1016/j.tifs.2019.07.032.
3. Ушакова Н.А., Понамарев С.В., Федоровых Ю.В., Бастракова А.И., Павлов Д.С. Физиологические основы питательной ценности концентрата личинок *Hermetia illucens* в рационе рыб // Известия Российской академии наук. Серия биология. 2020. № 3. С. 293–300.
4. Чой Е.Д., Ли В.В., Деркембаева Ж.С., Жолборсов А.А., Джурсаева С.Д., Тукешов С.К., Эшмуратов А.Б., Туркменов А.А. Глобальные перспективы использования личинок мухи черная львинка (Black soldier fly) в животноводческом корме, питании, фармакологии и косметологии (обзор литературы) // Уральский медицинский журнал. 2020. № 10. С. 193–204.
5. Gasko L., Biancarosa I., Liland N.S. From waste to feed: A review of recent knowledge on insects as producers of protein and fat for animal Feeds // Current Opinion in Green and Sustainable Chemistry. 2020. Vol. 23. P. 67–79. DOI: 10.1016/j.cogsc.2020.03.003.
6. Alfiko Y., Xie D., Astuti R.T., Le Wang J.W. Insects as a feed ingredient for fish culture: Status and trends // Aquaculture and Fisheries. 2022. N 7. P. 166–178. DOI: 10.1016/j.aaf.2021.10.004.
7. Некрасов Р.В., Чабаев М.Г., Зеленчикова А.А., Бастраков А.И., Ушакова Н.А. Питательные свойства личинок *Hermetia illucens* L. – нового кормового продукта для молодняка свиней // Сельскохозяйственная биология. 2019. Т. 54. № 2. С. 316–325. DOI: 10.15389/agrobiology.2019.2.316rus.
8. Zotte D. A., Singh Y., Michiels J. Black Soldier Fly (*Hermetia Illucens*) as dietary source for laying quails: live performance, and egg physico-chemical quality, sensory profile and storage stability // Animals (Basel). 2019. – Vol. 25. N 3. P. 115. DOI: 10.3390/ani9030115.
9. Kozłowski K., Ognik K., Stepniowska A., Jskiewicz J., Zdunczyk Z., Kieronczyk B., Benzertiha A., Jozefiak D., Jankowski J. Growth performance, immune status and intestinal fermentative processes of young turkeys fed diet with additive of full fat meals from *Tenebrio molitor* and *Hermetia illucens* // Animal Feed Science and Technology. 2021. Vol. 278. P. 114994. DOI: 10.3390/ani10081339.
10. Tahamtani F.M., Ivarsson E., Wiklicky V., Lalander C., Wall H., Rodenburg T.B., Tuytens F.A.M., Hernandez C.E. Feeding live black soldier fly larvae (*Hermetia illucens*) to laying hens: effects of feed consumption, hen health, hen behavior, and egg quality // Poultry Science. 2021. Vol. 100. N 10. P. 101400. DOI: 10.1016/j.psj.2021.101400.
11. Khayrova A., Lopatin S., Varlamov V. Obtaining chitin, chitosan and their melanin complexes from insects // International Journal of Biological Macromolecules. 2021. Vol. 167. P. 1319–1328. DOI: 10.1016/j.ijbiomac.2020.11.086.
12. Мальцева Т.А. Исследование свойств высушенной личинки мухи *Hermetia illucens* и жира применительно к процессу отжима // Научный журнал КубГАУ. 2021. № 173. С. 1–11.

13. Андреева И.В., Шаталова Е.И., Ульянова Е.Г., Ходакова А.В., Агриколянская Н.И., Голохваст К.С. Техническая энтомология: история, современное состояние и перспективы развития // Сибирский вестник сельскохозяйственной науки. 2022. № 4. С. 32–47. DOI: 10.26898/0370-8799-2022-4-4.
  14. Mohammed A.E. Naiel, Samar S. Negm, Shakira Ghazanfar, Mustafa Shukry, Sameh A. Abdelnour. The risk assessment of high-fat diet in farmed fish and its mitigation approaches: a review // *Journal of Animal Physiology and Animal Nutrition*. 2023. Vol. 107. P. 948–969. DOI: 10.1111/jpn.13759.
- ## REFERENCES
1. Pavlovich G., Lebedev V., Kuz'min I. Topical character of protein production from larval biomass for commercial aquaculture. *Kombikorma = Compound feeds*, 2021, vol. 5, pp. 12–14. (In Russian).
  2. Govorushko S. Global status of insects as food and feed source: A review. *Trends in Food Science & Technolog*, 2019, vol. 91, pp. 436–445. DOI: 10.1016/j.tifs.2019.07.032.
  3. Ushakova N.A., Ponamarev S.V., Fedorovykh Yu.V., Bastrakova A.I., Pavlov D.S. Physiological basis of the nutritional value of a concentrate of *Hermetia illucens* larvae in fish diets. *Izvestiya Rossiiskoi akademii nauk. Seriya biologiya = Proceedings of the Russian Academy of Sciences. Biology Bulletin*, 2020, no. 3. pp. 293–300. (In Russian).
  4. Choi E.D., Li V.V., Derkembraeva Zh.S., Zholborsov A.A., Dzhuraeva S.D., Tukeshov S.K., Eshmuratov A.B., Turkmenov A.A. Global prospects for the use of black Soldier fly larvae in animal feed, nutrition, pharmacology and cosmetology (literature review). *Ural'skii meditsinskii zhurnal = Ural Medical Journal*, 2020, no. 10, pp. 193–204. (In Russian).
  5. Gasko L., Biancarosa I., Liland N.S. From waste to feed: A review of recent knowledge on insects as producers of protein and fat for animal Feeds. *Current Opinion in Green and Sustainable Chemistry*, 2020, vol. 23, pp. 67–79. DOI: 10.1016/j.cogsc.2020.03.003.
  6. Alfiko Y., Xie D., Astuti R.T., Le Wang J.W. Insects as a feed ingredient for fish culture: Status and trends. *Aquaculture and Fisheries*, 2022, no. 7, pp. 166–178. DOI: 10.1016/j.aaf.2021.10.004.
  7. Nekrasov R.V., Chabaev M.G., Zelenchikova A.A., Bastrakov A.I., Ushakova N.A. Nutritional properties of *Hermetia illucens* L., a new feed product for young pigs. *Sel'skokhozyaistvennaya biologiya = Agricultural Biology*, 2019, vol. 54, no. 2, pp. 316–325. (In Russian). DOI: 10.15389/agrobiology.2019.2.316rus.
  8. Zotte D. A., Singh Y., Michiels J. Black Soldier Fly (*Hermetia Illucens*) as dietary source for laying quails: live performance, and egg physico-chemical quality, sensory profile and storage stability. *Animals (Basel)*, 2019, vol. 25, no. 3, p. 115. DOI: 10.3390/ani9030115.
  9. Kozłowski K., Ognik K., Stępniewska A., Jskiewicz J., Zdunczyk Z., Kieronczyk B., Benzertih A., Jozefiak D., Jankowski J. Growth performance, immune status and intestinal fermentative processes of young turkeys fed diet with additive of full fat meals from *Tenebrio molitor* and *Hermetia illucens*. *Animal Feed Science and Technology*, 2021, vol. 278, p. 114994. DOI: 10.3390/ani10081339.
  10. Tahamtani F.M., Ivarsson E., Wiklicky V., Lalander C., Wall H., Rodenburg T.B., Tuytens F.A.M., Hernandez C.E. Feeding live black soldier fly larvae (*Hermetia illucens*) to laying hens: effects of feed consumption, hen health, hen behavior, and egg quality. *Poultry Science*, 2021, vol. 100, no. 10, p. 101400. DOI: 10.1016/j.psj.2021.101400.
  11. Khayrova A., Lopatin S., Varlamov V. Obtaining chitin, chitosan and their melanin complexes from insects. *International Journal of Biological Macromolecules*. 2021. vol. 167. pp. 1319–1328. DOI: 10.1016/j.ijbiomac.2020.11.086.
  12. Mal'tseva T.A. Research of the properties of dried *Hermetia illucens* fly larva and fat in relation to the extraction process. *Nauchnyi zhurnal KubGAU = Scientific Journal of KubSAU*, 2021, no. 173, pp. 1–11. (In Russian).
  13. Andreeva I.V., Shatalova E.I., Ul'yanova E.G., Khodakova A.V., Agrikolyanskaya N.I., Golokhvast K.S. Technical entomology: history, current state and prospects of development. *Sibirskii vestnik sel'skokhozyaistvennoi nauki = Siberian Herald of Agricultural Science*, 2022, no. 4, pp. 32–47. (In Russian). DOI: 10.26898/0370-8799-2022-4-4.
  14. Mohammed A.E. Naiel, Samar S. Negm, Shakira Ghazanfar, Mustafa Shukry, Sameh A. Abdelnour. The risk assessment of high-fat diet in farmed fish and its mitigation approaches: a review. *Journal of Animal Physiology and Animal Nutrition*, 2023, vol. 107, pp. 948–969. DOI: 10.1111/jpn.13759.

## ИНФОРМАЦИЯ ОБ АВТОРАХ

✉ **Лукьянчикова Н.Л.**, кандидат биологических наук, ведущий научный сотрудник, заведующий лабораторией; **адрес для переписки:** Россия, 630501, Новосибирская область, р.п. Краснообск, а/я 463; e-mail: lukyanchikovanl@sfscs.ru

**Цимбалова Т.А.**, инженер

**Андреева И.В.**, кандидат сельскохозяйственных наук, ведущий научный сотрудник, заведующая лабораторией

**Шаталова Е.И.**, кандидат биологических наук, старший научный сотрудник

**Рогачев В.А.**, доктор сельскохозяйственных наук, заведующий лабораторией

## AUTHOR INFORMATION

✉ **Nina L. Lukyanchikova**, Candidate of Science in Biology, Lead Researcher, Laboratory Head; **address:** PO Box 463, Krasnoobsk, Novosibirsk Region, 630501, Russia; e-mail: lukyanchikovanl@sfscs.ru

**Tatiana A. Tsimbalova**, Engineer

**Irina V. Andreeva**, Candidate of Science in Agriculture, Lead Researcher, Laboratory Head

**Elena I. Shatalova**, Candidate of Science in Biology, Senior Researcher

**Victor A. Rogachev**, Doctor of Science in Agriculture, Laboratory Head

*Дата поступления статьи / Received by the editors 29.03.2024*  
*Дата принятия к публикации / Accepted for publication 25.05.2024*  
*Дата публикации / Published 20.11.2024*

## Особенности проявления лейкоза крупного рогатого скота на территории Республики Тыва

✉ Лопсан Ч.О.

*Тувинский научно-исследовательский институт сельского хозяйства – филиал Сибирского федерального научного центра агробιοтехнологий Российской академии наук*

Республика Тыва, г. Кызыл, Россия

✉ e-mail: tuv\_niish@mail.ru

Выявлены особенности проявления лейкоза крупного рогатого скота (ЛКРС) на территории Республики Тыва за 1974–2023 гг. Установлены эпизоотологические показатели неблагополучия, индекса эпизоотичности и индекса очаговости. За все время наблюдения лейкоз на территории 7 высокогорных и отдаленных районов не зарегистрирован. Одной из особенностей благополучия высокогорных и отдаленных районов являются природные и географические условия (изолированное расположение, окруженное горами, занимающими 80% территории региона, ограниченные связи с другими регионами, труднодоступность). Другая особенность – отгонное ведение животноводства, в основном аборигенного скота на подножном корме, с частыми сменами пастбищ и вольным содержанием. С расширением экономических связей, завозом племенного молочного скота из соседних регионов (по результатам исследований, неблагополучных по лейкозу крупного рогатого скота) эпизоотическая ситуация обрела неблагополучие. Это является главной особенностью неблагополучия региона по лейкозу. Лейкоз регистрируется в основном в центральных районах, расположенных на равнинных территориях межгорных котловин, где имеются благоприятные условия для содержания и кормления молочного скота. При совместных условиях содержания и эксплуатации существует риск заражения остальных животных, что является также особенностью лейкоза на территории Республики Тыва. Впервые лейкоз крупного рогатого скота зарегистрирован в Улуг-Хемском районе на молочно-товарной ферме в 1977 г. у коровы голштиннофризской породы. Из 50 лет наблюдения в течение 29 лет в республике зарегистрировано несколько неблагополучных по лейкозу районов (Тандынский, Пии-Хемский, Каа-Хемский, Чеди-Холский, Улуг-Хемский и др.), в общей сложности 60 неблагополучных пунктов. Исследовано 914 638 животных, выявлено 845 гол. положительно реагирующих, или 0,09% всего исследованного по республике поголовья, неблагополучие (НБ) составило 40,8%, индекс эпизоотичности (ИЭ) за 50 лет наблюдения составил 1,2 ед., индекс очаговости (ИО) – 14,08 серопозитивных голов на один неблагополучный пункт. Спорадические и единичные случаи на территории остальных 6 неблагополучных районов (Барун-Хемчикском, Сут-Холском, Кызылском, г. Кызыл, Тес-Хемском, Тоджинском) также связаны с завозом племенного скота, где с проведением диагностических и других противоэпизоотических мероприятий ситуация, не имея эпизоотического и географического развития, быстро улучшалась. Республика Тыва с 2022 г. по лейкозу крупного рогатого скота благополучна.

**Ключевые слова:** лейкоз крупного рогатого скота, исследования, положительно реагирующие животные

## Features of bovine leukosis manifestation on the territory of the Republic of Tuva

✉ Lopsan Ch.O.

*Tuvinian Scientific Research institute of Agriculture – Branch of the Siberian Federal Scientific Centre of Agro-BioTechnologies of the Russian Academy of Sciences*

Kyzyl, Republic of Tuva, Russia

✉ e-mail: tuv\_niish@mail.ru

The peculiarities of bovine leukosis virus (BLV) manifestation on the territory of the Republic of Tuva for 1974–2023 have been revealed. Epizootologic indicators of the disease status, epizootic index and nidus index have been established. During the whole period of observation leukosis has not

been registered on the territory of 7 highland and remote districts. One of the features of the well-being of highland and remote areas are natural and geographical conditions (isolated location surrounded by mountains occupying 80% of the region's territory, limited connections with other regions, difficult accessibility). Another peculiarity is free range animal husbandry, mainly indigenous cattle on fodder, with frequent changes of pastures and free keeping of cattle. With the expansion of economic ties, importation of pedigree dairy cattle from the neighboring regions (which, according to the results of the studies, are unfavorable in terms of bovine leukosis), the epizootic situation became unfavorable. This is the main feature of the region's leukosis adversity. Leukosis registered mainly in the central districts located in the flat territories of intermountain basins, where there are favorable conditions for maintenance and feeding of dairy cattle. Under joint conditions of keeping and exploitation there is a risk of infection of other animals, which is also a feature of leukosis on the territory of the Republic of Tuva. Bovine leukosis was first registered in the Ulug-Khemsy district at a dairy farm in 1977 in a cow of the Holstein Friesian breed. Out of 50 years of observation, 11 leukosis-affected districts (Tandynsky, Pii-Khemsy, Kaa-Khemsy, Chedi-Kholsky, Ulug-Khemsy, etc.), totaling 60 leukosis-affected points, have been registered in the republic for 29 years. 914,638 animals were examined, 845 animals were found to be positive, or 0.09% of the total number of the livestock examined in the country, the disease status was noted in 40.8%, the epizootic index (EI) for 50 years of observation amounted to 1.2 units, the nidus index (NI) – 14.08 seropositive animals per 1 unfavorable location. Sporadic and isolated cases on the territory of the remaining 6 unfavorable districts (Barun-Khemchiksky, Sut-Kholsky, Kyzyl, Kyzyl city, Tes-Khemsy, Tojinsky) are also associated with the importation of breeding cattle, where with the implementation of diagnostic and other anti-epizootic measures, the situation, without epizootic and geographical development, rapidly improved. The Republic of Tuva has been free from bovine leukosis since 2022.

**Keywords:** bovine leukosis, research, positively-reacting animals

**Для цитирования:** Лопсан Ч.О. Особенности проявления лейкоза крупного рогатого скота на территории Республики Тыва // Сибирский вестник сельскохозяйственной науки. 2024. Т. 54. № 10. С. 118–127. <https://doi.org/10.26898/0370-8799-2024-10-12>

**For citation:** Lopsan Ch.O. Features of bovine leukosis manifestation on the territory of the Republic of Tuva. *Sibirskii vestnik sel'skokhozyaistvennoi nauki = Siberian Herald of Agricultural Science*, 2024, vol. 54, no. 10, pp. 118–127. <https://doi.org/10.26898/0370-8799-2024-10-12>

**Конфликт интересов**

Автор заявляет об отсутствии конфликта интересов.

**Conflict of interest**

The author declares no conflict of interest.

## INTRODUCTION

Bovine leukosis is a chronic infectious disease caused by a lymphotropic virus of the family Retroviridae, subfamily Oncornaviridae, type E, which includes T-cell leukemia viruses responsible for the humoral (B-leukocytes) and cellular (T-lymphocytes) immunity of animals and humans [1, 2]. These cells have the ability to transform into tumor cells (hemoblastoses). Their metabolites accumulate in meat, are excreted through milk, and the consumption of products from animals in clinical-hematological and tumor stages can lead to the development

of the disease. Bovine leukosis often progresses asymptotically for a long time, later manifesting as high lymphocytosis and tumor formations in organs and tissues. The development of bovine leukosis is divided into the incubation, infectious, hematological, and final tumor stages of the disease. The incubation period lasts from 2 months to 6 years. The disease is transmitted through contact, alimentary, and intrauterine transplacental routes during the last two trimesters of pregnancy. For leukosis, no vaccines or medications have been developed, so infected cattle are sent for slaughter. The bovine leukosis

virus was first identified in 1969 in the United States from a sick cow. Currently, bovine leukosis is widespread in many countries, including the United States, Canada, China, Japan, and the Russian Federation. Western European countries are considered free of the bovine leukosis virus (BLV). In the USSR, bovine leukosis (BLV) was first introduced in 1940, 1945–1947 through breeding cattle imported from Germany into the western regions of the country, and gradually, leukemia began to be observed in other regions of the Russian Federation [3]. In the Russian Federation, outbreaks of bovine leukosis have been recorded in regions close to the Republic of Tuva, such as the Altai Territory<sup>1</sup> [4–6], the Republic of Khakassia, and the Krasnoyarsk Territory, from where Tuva's farms purchase breeding cattle. The disease causes significant economic damage to livestock farming due to forced slaughter, reduced offspring, decreased quantity and quality of dairy and meat products, and increased costs for anti-epizootic measures, posing a medical and biological problem for the environment. Additionally, milk and meat from animals infected with BLV contain carcinogenic and environmentally hazardous metabolites of tryptophan, lysine, and other cyclic amino acids<sup>2</sup> [7–10].

The purpose of the research is to study the peculiarities of bovine leukosis manifestation in the Republic of Tuva over the period of 1974–2023.

## MATERIAL AND METHODS

The data of annual reports of veterinary laboratories of the Veterinary Service of the Republic of Tuva served as the material for the research.

For retrospective analysis the specific weight of unfavorable locations was calculated, which

characterizes the breadth of the disease in percent<sup>3,4</sup>, calculated by the formula

$$UL = \frac{\text{The number of unfavorable locations}}{\text{The number of settlements}} \times 100.$$

One of the indicators of the intensity of the epizootic situation, the epizootic index (EI), characterizes the intensity of the epizootic situation in time (see footnotes 3, 4) and is calculated by the formula

$$EI = \frac{\text{The number of years during which the disease was registered}}{\text{The number of years of observation}} \times 100.$$

We were also interested in the focality index (FI), which characterizes the number of sick animals per one infected site (see footnotes 3, 4)

$$FI = \frac{\text{The number of sick animals}}{\text{The number of unfavorable locations}}$$

The research work was carried out on the basis of Tuva Research Institute of Agriculture – branch of SFSCA RAS in 2023.

## RESULTS AND DISCUSSION

The geographical location of the Republic of Tuva is characterized by alternating mountain ranges and intermontane basins. Mountain ranges occupy about 80% of the territory (on average, only in the basin, the elevation above sea level ranges from 520 to 1200 meters), while the remaining part consists of flat steppe areas. The Republic of Tuva is an agrarian region with a predominance of transhumant sheep farming, and dairy cattle breeding is developed in the central districts located on the flat territories of intermontane basins.

<sup>1</sup>Rosselkhoznadzor. Epizootic situation in the Russian Federation, 2020. URL: [https://fsvps.gov.ru/fsvps-docs/ru/iac/rf/2020/iac2020\\_all.pdf](https://fsvps.gov.ru/fsvps-docs/ru/iac/rf/2020/iac2020_all.pdf)

<sup>2</sup>Timoshina S.V., Badeeva O.B. Economic damage in bovine leukosis in cattle // *Veterinary Medicine*, 2016, N 4, pp. 23–24.

<sup>3</sup>Dzhupina S.I., Kolosov A.A. Methods of epizootologic research. Methodological recommendations, RAAS, Siberian Branch, Novosibirsk, 1991, 61 p.

<sup>4</sup>Sidorchuk A.A., Voronin E.S., Glushkov A.A. General epizootology. Moscow: Kolos, 2005, 176 p.

In the Republic of Tuva, over the analyzed period of 1974–2023 (50 years), out of the 18 administrative-territorial units, leukosis has not been registered in 7 high-mountain and remote districts (Bai-Taiginsky, Mongun-Taiginsky, Dzun-Khemchiksky, Chaa-Kholsky, Erzinsky, Ovursky, and Tere-Kholsky), where, after the restructuring of ownership, dairy farms have not been restored, and sheep farming and beef cattle breeding are mainly developed. In 11 districts (Barun-Khemchiksky, Sut-Kholsky, Ulug-Khemsy, Tandinsky, Pii-Khemsy, Kaa-Khemsy, Chedi-Kholsky, Kyzylsky, the city of Kyzyl, Tes-Khemsy, and Todzhinsky), leukosis has been registered in different years with varying intensity.

For the first time in the Republic of Tyva, laboratory diagnosis of bovine leukosis began in 1974 using the method of counting leukocytes and lymphocytes in peripheral blood on a Goryaev chamber under a light microscope, which detects leukosis with persistent long-term progression in the final tumor stage. Leukosis was first registered in 1977 on the dairy farm of the state farm 'Ak-Turug' in the Ulug-Khemsy district in 1 head of cattle, accounting for 0.13% of the breeding stock examined across the republic (752 heads)".

For the whole analyzed period 16 308 animals were tested for leukosis by hematological method, 21 sick animals or 0,13% of the examined livestock were detected. In 1974–1989 on dairy farms of state farms out of 4493 animals 7 sick animals or 0,15% of the herd were detected, in 1990–2005 out of 61 Holstein-Friesians brought to dairy farms 8 animals were detected positively reacting in IDR with its introduction, which made 13,1%, in 2006–2023 out of 331 animals positively reacting in IDR and ELISA 6 animals were detected or 1,8%. All leukemia-positive animals aged two years and older were immediately sent to slaughter after the results were obtained. However, no pathological and anatomical changes characteristic of leukemia were detected during post-slaughter examination.

The modern at that time method of antibody detection in the reaction of immune diffusion in agar gel (IDR) was developed in Russia in 1985 and has been used in Russia since 1986 [11]. This test system is designed to detect antibodies to the glycoprotein antigen of bovine leukosis virus in the blood serum of animals by precipitation in agar gel. A positive reaction is evaluated as a carrier of leukosis virus. The method was introduced in the Republic of Tuva in diagnostics in the main Tuva veterinary laboratory in 1990, the research was conducted only in the service area of this laboratory – in the same central districts, where more seropositive were investigated and detected than in other districts, as inter-district laboratories started IDR-diagnostics only in 2000.

The greatest number of years of research 1990–2023 (34 years), coverage of territories of districts, the number of animals tested for leukosis, positively reacting, were found using the method of IDR-diagnostics. 914,638 cattle were tested in IDR, 733 animals seropositive for leukosis were detected, or 0.08% of the total number of animals tested in the country.

The ELISA method of laboratory diagnostics is used to detect specific antibodies to bovine leukosis virus gp51 in serum and blood plasma, bovine milk. Their presence is evaluated as a carrier of the leukemia virus. In Russia ELISA began to use in 1989, in the Republic of Tuva – only in 2006. For 2006–2023 (18 years) 108 679 animals were examined, 516 positive animals were detected in ELISA, results of the IDR and ELISA studies coincided in 838 cases, except for 7 cases detected only in hematologic studies in 1974–1989.

No pathologic-anatomical changes were detected at post-slaughter examination when positives were detected in the IDR and ELISA tests.

In recent years, the increase in the number of the animals positive for leukosis has been influenced by the importation of a large number of pedigree dairy cattle under the State Program to improve the breed of cattle, intensification of dairy production.

There are 147 settlements on the territory of the Tuva Republic, for 50 years of analysis a total of 60 infected sites (60 years, times) have been registered, the number of unfavorable loca-

tions (UL) accounted for 40.8%, the epizootic index (EI) – 1.2 units, the focality index (FI) – 14.08 seropositive animals per 1 infected point (see Tables 1–3).

**Табл. 1.** Степень неблагополучия (НБ) по лейкозу крупного рогатого скота на территории Республики Тыва за 1974–2023 гг.

**Table 1.** The degree of infestation (DI) with bovine leukosis in the territory of the Republic Tuva for 1974–2023

Administrative-territorial unit	Number of settlements	Year and degree of unfavorability							
		1974–1989 (16 years)	UnF, %	1990–2005 (16 years)	UnF, %	2006–2023 гг. (18 years)	UnF, %	1974–2023 (50 years)	UnF %
Republic of Tuva, total	147	4	2,72	18	12,24	38	25,8	60	40,8
Barun-Khemchiksky						1	0,68	1	0,68
Sut-Kholsky				1	0,68			1	0,68
Ulug-Khemsy		1	0,68	1	0,68	2	1,36	4	2,72
Tandinsky				6	4,08	15	10,2	21	14,2
Chedi-Kholsky						6	4,08	6	4,08
Kyzyl				1	0,68			1	0,68
Kyzylsky		2	1,36					2	1,36
Kaa-Khemsy		1	0,68	2	1,36	2	1,36	5	3,4
Pii-Khemsy				5	3,40	9	6,12	14	9,52
Tes-Khemsy				2	1,36	1	0,68	3	2,04
Todzhinsky						2	1,36	2	0,36

**Табл. 2.** Индекс эпизоотичности (ИЭ) по лейкозу крупного рогатого скот на территории Республики Тыва за 1974–2023 гг.

**Table 2.** Epizootic index (EI) for bovine leukosis in the territory of the Republic Tuva for the period of 1974–2023

Administrative-territorial unit	Number of settlements	Number of unfavorable years (sites) and epizootic index							
		1974–1989 (16 years)	%	1990–2025 (16 years)	%	2006–2023 (18 years)	%	1974–2023 (50 years)	%
Republic of Tuva, total	147	4	0,25	18	1,12	38	2,11	60	1,2
Barun-Khemchiksky						1	0,05	1	0,02
Sut-Kholsky				1	0,06			1	0,02
Ulug-Khemsy		1	0,06	1	0,06	2	0,11	4	0,08
Tandinsky				6	0,37	15	0,83	21	0,42
Chedi-Kholsky						6	0,33	6	0,12
Kyzyl				1	0,06			1	0,02
Kyzylsky		2	0,12					2	0,04
Kaa-Khemsy		1	0,06	2	0,12	2	0,11	5	0,1
Pii-Khemsy				5	0,31	9	0,5	14	0,28
Tes-Khemsy				2	0,12	1	0,05	3	0,06
Todzhinsky						2	0,11	2	0,04

**Табл. 3.** Индекс очаговости (ИО) по лейкозу крупного рогатого скота на территории Республики Тыва за 1974–2023 гг.  
**Table 3.** Nidus index (NI) for bovine leukosis in the territory of the Republic Tuva for the period of 1974–2023

Administrative-territorial unit	1974–1989			1990–2005			2006–2023			Total for 1974–2023		
	Number of unfavorable locations	Sick, heads	NI, heads	Number of unfavorable locations	Sick and positive responders, heads	NI, heads	Number of unfavorable locations	Sick and positive responders, heads	NI, heads	Number of unfavorable locations	Sick and positive responders	NI, heads
Republic of Tuva, total	4	7	1,75	18	294	16,33	38	544	14,3	60	845	14,08
Barun-Khemchiksky							1	2	2	1	2	2
Sut-Kholsky				1	10	10				1	10	10
Ulug-Khemsy	1	1	1	1	4	4	2	4	2	4	9	2,25
Tandinsky				6	191	31,8	15	365	24,3	21	556	26,47
Chedi-Kholsky							6	26	4,33	6	26	4,33
Kyzyl				1	1	1				1	1	1
Kyzylsky	2	5	2,5							2	5	2,5
Kaa-Khemsy	1	1	1	2	40	20	2	6	3	5	47	9,4
Pii-Khemsy				5	46	13,55	9	122	13,55	14	168	12
Tes-Khemsy				2	2	2	1	2	2	3	4	1,33
Todzhinsky				2	17	8,5	2	17	8,5	2	17	8,5

From the data of the tables, it is seen that 4 unfavorable sites were registered in 1974–1989 only according to the results of hematological studies, epizootological indices of UL, EI and FI were respectively 2,72%, 0,25 units, and 1,75 positive animals per 1 unfavorable site. Eighteen infected sites, 294 seropositive animals were registered during the period of using one IDR-study for leukosis diagnostics (1990–2005), the infectiousness was 12,24%, EI – 1,12 units, FI was 16,33 animals per 1 infected site. With the introduction of ELISA method and its combined use with IDR-diagnostics (2006-2023), the number of infected sites and virus-carrying animals became twice as high: 38 infected sites, 544 seropositive animals were detected, infectiousness amounted to 25.85%, epizootic index (EI) for 50 years of observation amounted to 2.11 units, FI – 14.3 seropositive animals per 1 infected site.

Detection of positively reactive animals is more observed in the central districts, located on the plains, favorable for the development of dairy cattle breeding [12] and in which diagnostic tests in IDR and ELISA were started earlier than in interdistrict laboratories. The most tense situation is observed in the Tandynsky district, where a total of 21 unfavorable sites were registered in 1990–2023 (21 years), 556 positive animals were detected, the unfavorability was (UL) 14.2%, EI – 0.42 units, FI – 26.47 heads.

The next by the level of epizootic tension was Pii-Khemsy district: 168 positively reacting heads in 14 the unfavorable settlements were detected during the whole period of research, the level of unfavorability amounted to 9.52%, EI – 0.28 units, FI – 12 heads positively reacting to the unfavorable site.

Kaa-Khemsy district was the third in detection of positively reacting animals, for the whole period 1974–2023 47 positively reacting animals were detected, 5 unfavorable sites, unfavorability amounted to 3.4%, EI – 0.10 units; FI – 9.4 heads.

In the Chedi-Kholsky district, leukosis has been observed since 2011 due to the forma-

tion of a milking gort from the purchased Holstein-Friesians from the neighboring region, a total of 6 infected sites were identified, 26 seropositive animals, UL was 4.08%, EI – 0.12 units, FI – 4.33 heads.

Single and sporadic cases of bovine leukosis in different years and periods are observed in the central districts. In the Ulug-Khemsy district in different periods of observation 4 unfavorable sites were identified (1977, 1990, 2009, 2012), 9 positively reacting heads, first in the dairy farms of state farms, after - in large peasant-farms associated with the importation of breeding cattle, but after their sending to slaughter leukosis was usually not traced, unfavorability was 2.72%, EI – 0.08 units, FI – 2.25 heads. In the Kyzylsky district leukosis was registered in 1978, 1981 in 2 cows in a large dairy farm of the state farm “Kok-Tei”, which after restructuring was not restored, epizootological indicators were: UL - 1.36, EI - 0.04 units, FI - 2.5 cows. In the suburb of the capital city Kyzyl, located on a flat area in the central part of the region, in a subsidiary farm in 2005 1 unfavorable site was registered, 1 positive cow bought from a nearby unfavorable farm of the Pii-Khemsy district, the unfavorability was 0.68%, EI - 0.06 units, FI - 1 animal per 1 unfavorable site.

Sporadic and isolated cases were also observed on the territory of other unproblematic districts: southern Tes-Khemsy, eastern Barun-Khemchiksky, Sut-Kholsky, specializing mainly in sheep breeding and keeping of universal indigenous cattle, where dairy farms have not been restored after restructuring of property, as well as on the territory of hunting and fishing Tojinsky district, specializing mainly in reindeer breeding and hunting and fishing. All cases of leukosis are also associated with the importation of breeding cattle, but to a lesser extent, so the epizootic situation with the immediate sending of seropositive animals for slaughter directly from the herd, without overstaying in the field, the adoption of other anti-epizootic measures quickly stabilize.

The Republic of Tuva has been free from bovine leukosis since 2022.

To prevent the spread of bovine leukosis in the region, the following measures are being implemented:

– hematological and serological studies in IDR and ELISA for leukosis and leukosis virus carriage of blood serum samples from breeding stock of cattle;

– when detecting sick and infected with bovine leukosis virus, they are sent for slaughter immediately, without overstaying, directly from the herd, and all other breeding stock is examined after 3 months until two consecutive negative results are obtained.

– in order to prevent further development of the disease to clinical manifestation, to prevent its spread in the region, together with the patients detected by hematological tests, the positive carriers of the virus in IDR and ELISA tests should be removed from the herd with further tests of the rest of the animals after 30 days until twofold negative results with observance of all anti-epizootic, veterinary, sanitary and organizational measures, according to the current regulatory and technical documents<sup>5</sup>.

## CONCLUSION

In the Republic of Tuva hematological studies for bovine leukosis were performed mainly before the collapse of dairy farms. With the introduction of IDR, then ELISA-diagnostics, hematological studies are carried out only in some years, selectively in small quantities from positively reacting animals in IRD and ELISA studies.

Leukosis detected by hematological tests and virus carrier detected by serological tests are observed in imported breeding stock of the Holstein-Friesian breed from neighboring unfavorable regions at the age of 2 years and older.

At present, the welfare of the Republic of Tuva is achieved by the removal of sick animals

and carriers of leukosis virus before the development of clinical stage and pathological-anatomical changes with the observance of anti-epizootic, veterinary-sanitary and organizational measures in the conditions of a cattle-breeding republic, where meat and milk are traditionally the main foodstuffs of the population.

## СПИСОК ЛИТЕРАТУРЫ

1. *Целуева Н.И.* Ретроспективный анализ эпизоотической ситуации по лейкозу крупного рогатого скота в Смоленской области // Ветеринария Кубани. 2022. № 5. С. 9–13. DOI: 10.33861/2071-8020-2022-5-9-13.
2. *Агасиев А.Ш., Козловская А.Ю., Дмитриева О.С., Половинцева Т.М.* Эпизоотическая ситуация по лейкозу крупного рогатого скота в Псковской области // Эффективное животноводство. 2021. № 2 (168). С. 106–109.
3. *Мустафаев А.Р., Баратов М.О.* Ретроспективный анализ распространения лейкоза крупного рогатого скота в Республике Дагестан с учетом природно-климатических условий // Ветеринария сегодня. 2023. № 12 (4). С. 308–314. DOI: 10.29326/2304-196X-2023-12-4-308-314.
4. *Мустафаев А.Р.* Эпизоотическая остановка по энзоотичному лейкозу крупного рогатого скота в общественных и индивидуальных хозяйствах Республики Дагестан // Ветеринария сегодня. 2021. № 2. С. 144–150. DOI: 10.29326/2304-196X-2021-2-37-144-150.
5. *Мустафаев А.Р., Гулюкин М.И., Салихов Ю.С.* Мониторинг по распространению вируса лейкоза крупного рогатого скота в Республике Дагестан за 2018 год // Ветеринария и кормление. 2019. № 4. С. 18–20. DOI: 10.30917//АТТ-ВК-1814-9588-2019-4-5.
6. *Мустафаев А.Р., Баратов М.О.* Сравнительные аспекты диагностики лейкоза крупного рогатого скота при применении реакции иммунодиффузии и иммуноферментного анализа // Ветеринария сегодня. 2023. № 12 (1). С. 52–56. DOI: 10.29326/2304-196X-2023-12-1-52-56.
7. *Ягудин.Р., Сличенко С.А., Усова И.А., Строганова И.Я.* Комплекс мероприятий по борьбе

<sup>5</sup>Order of the Ministry of Agriculture of the Russian Federation No. 156 of 24.03.2021 “On Approval of Veterinary Rules for the implementation of preventive, diagnostic, restrictive measures, establishment and lifting of quarantine and other restrictions aimed at preventing the spread and elimination of foci of bovine leukosis”.

- бе с лейкозом крупного рогатого скота // Ветеринария сегодня. 2022. № 11(3). С. 248–253. DOI:10.29326/2304-196X-2022-11-3-248-253.
8. Целуева Н.И., Гамаюнов В.М. Лейкоз крупного рогатого скота в Смоленской области // Ветеринария. 2018. № 11. С. 23–26. DOI: 10.30896/0042-4846.2018.21.11.23-26.
  9. Гулюкин М.И., Барсуков Ю.И., Логинов С.И., Агаркова Т.А., Разумовская В.В., Двоеглазов Н.Г., Осипова Н.Н. Анализ эпизоотической ситуации по лейкозу крупного рогатого скота в Сибирском Федеральном Округе // Сибирский вестник сельскохозяйственной науки. 2021. Т. 51. № 4. С. 67–75. DOI: 10.26898/0370-8799-2021-4-8.
  10. Осипова Н.А., Агаркова Т.А., Двоеглазов Н.Г., Храмов В.В. Оценка эффективности комплексных противолейкозных мероприятий сельскохозяйственных предприятий // Сибирский вестник сельскохозяйственной науки. 2019 № 5. С. 73–79. DOI: 10.26898/03708799-2019-5-10.
  11. Целуева Н.И. Проблема лейкоза крупного рогатого скота и пути ее решения // Международный вестник ветеринарии. 2019. № 2. С. 33–38. DOI: 10.30896/0042-4846.2018.21.11.23-26.
  12. Мустафаев А.Р., Баратов М.О. Ретроспективный анализ распространения лейкоза крупного рогатого скота в Республике Дагестан с учетом природно-климатических условий // Ветеринария сегодня. 2023. № 12 (4). С. 308–314. DOI: 10.29326/2304-196X-2023-12-4-308-314.
- pp. 308–314. (In Russian). DOI: 10.29326/2304-196X-2023-12-4-308-314.
4. Mustafaev A.R. Epidemic situation on enzootic bovine leukosis in public and individual farms in the Republic of Dagestan. *Veterinariya segodnya = Veterinary Science Today*. 2021, no. 2, pp. 144–150. (In Russian). DOI: 10.29326/2304-196X-2021-2-37-144-150.
  5. Mustafaev A.R., Gulyukin M.I., Salikhov Yu.S. Monitoring of the spread of bovine leukemia virus in the Republic Dagestan in 2018. *Veterinariya i kormlenie = Veterinariya i kormlenie*, 2019, no. 4, pp. 18–20. (In Russian). DOI: 10.30917//ATT-VK-1814-9588-2019-4-5.
  6. Mustafaev A.R., Baratov M.O. Comparative assessment of immunodiffusion and enzyme-linked immunosorbent assay used for bovine leukosis diagnosis. *Veterinariya segodnya = Veterinary Science Today*, 2023, no. 12 (1), pp. 52–56. (In Russian). DOI: 10.29326/2304-196X-2023-12-1-52-56.
  7. Yagudin R., Slichenko S.A., Usova I.A., Stroganova I.Y. Bovine leukosis control measures. *Veterinariya segodnya = Veterinary Science Today*, 2022, no. 11 (3), pp. 248–253. (In Russian). DOI: 10.29326/2304-196X-2022-11-3-248-253.
  8. Tselueva N.I., Gamayunov V.M. Leukemia of cattle in the Smolensk region. *Veterinariya = Veterinary Medicine*, 2018, no. 11, pp. 23–26. (In Russian). DOI: 10.30896/0042-4846.2018.21.11.23-26.
  9. Gulyukin M.I., Barsukov Yu.I., Loginov S.I., Agarkova T.A., Razumovskaya V.V., Dvoeglazov N.G., Osipova N.N. Analysis of the enzootic situation of cattle leukemia in the Siberian Federal District. *Sibirskii vestnik sel'skokhozyaistvennoi nauki = Siberian Herald of Agricultural Science*, 2021, vol. 51, no. 4, pp. 67–75. (In Russian). DOI: 10.26898/0370-8799-2021-4-8.
  10. Osipova N.A., Agarkova T.A., Dvoeglazov N.G., Khramtsov V.V. Estimation of efficiency of comprehensive anti-leukemia measures in agricultural enterprises. *Sibirskii vestnik sel'skokhozyaistvennoi nauki = Siberian Herald of Agricultural Science*, 2019, no. 5, pp. 73–79. (In Russian). DOI: 10.26898/03708799-2019-5-10.
  11. Tselueva N.I. The problem of leukemia in cattle and ways to solve it. *Mezhdunarodny vestnik veterinarii = International Journal of Veterinary*

## REFERENCES

1. Tselueva N.I. Retrospective analysis of the enzootic situation of bovine leukemia in the Smolensk region. *Vetepinariya Kubani = Veterinariya Kubani*, 2022, no. 5, pp. 9–13. (In Russian). DOI: 10.33861/2071-8020-2022-5-9-13.
2. Agasiev A.Sh., Kozlovskaya A.Yu., Dmitrieva O.S., Polovintseva T.M. Epizootic situation of bovine leukemia in the Pskov region. *Effektivnoe zhivotnovodstvo = Efficient animal husbandry*, 2021, no. 2 (168), pp. 106–109. (In Russian).
3. Mustafaev A.R., Baratov M.O. Retrospective analysis of enzootic bovine leucosis spread in Republic of Dagestan considering natural and climatic conditions. *Veterinariya segodnya = Veterinary Science Today*, 2023, no. 12 (4),

*Medicine*, 2019, no. 2, pp. 33–38. (In Russian).  
DOI: 10.30896/0042-4846.2018.21.11.23-26.

12. Mustafaev A.R., Baratov M.O. Retrospective analysis of the spread of bovine leukemia in the Republic Dagestan, taking into account natural

and climatic conditions. *Veterinariya segodnya = Veterinary Science Today*, 2023, no. 12 (4), pp. 308–314. (In Russian). DOI: 10.29326/2304-196X-2023-12-4-308-314.

#### ИНФОРМАЦИЯ ОБ АВТОРЕ

✉ **Лопсан Ч.О.**, кандидат ветеринарных наук, старший научный сотрудник; **адрес для переписки:** Россия, 667005, Республика Тыва, г. Кызыл, ул. Бухтуева, 4; e-mail: tuv\_niish@mail.ru

#### AUTHOR INFORMATION

✉ **Chechek O. Lopsan**, Candidate of Science in Veterinary Medicine, Senior Researcher; **address:** 4, Bukhtueva St., Kyzyl, Republic of Tuva, 667005, Russia; e-mail: tuv\_niish@mail.ru

*Дата поступления статьи / Received by the editors 05.06.2024*  
*Дата принятия к публикации / Accepted for publication 05.08.2024*  
*Дата публикации / Published 20.11.2024*



<https://doi.org/10.26898/0370-8799-2024-10-13>

УДК: 681.2:632.08

Тип статьи: оригинальная

Type of article: original

## Разработка устройства для диагностики пятнистостей земляники садовой

✉ Минеев В.В.<sup>1</sup>, Ёлкин О.В.<sup>1</sup>, Алейников А.Ф.<sup>1,2</sup>, Морозов В.Б.<sup>1</sup>, Рихтер В.А.<sup>1</sup>

<sup>1</sup>Сибирский федеральный научный центр агробиотехнологий Российской академии наук  
Новосибирская область, р.п. Краснообск, Россия

<sup>2</sup>Новосибирский государственный технический университет  
Новосибирск, Россия

✉ e-mail: mineevfti@yandex.ru

Описаны симптомы при поражении листьев земляники садовой пятнистостями, вызванными фитопатогенными грибами. Показана невозможность их идентификации по видимым признакам в начальной стадии поражения. Ранняя диагностика возможна с помощью методов, основанных на взаимодействии антител с антигенами фитопатогенов, молекулярных методов анализа и методов на основе аптамеров. Однако при их использовании имеется ряд трудностей. Для создания портативного средства ранней диагностики предложены методы, основанные на детектировании электрических изменений в растительных тканях листьев в результате атаки грибов-патогенов: метод электрической импедансной спектроскопии и метод электрических эквивалентных схем. Методы позволяют определить диагностический параметр – емкость конденсатора, моделирующего емкость мембран растительных клеток листьев. Выявлено, что значения емкости конденсатора уменьшаются по мере повышения степени поражения листьев земляники. Предложенные методы реализованы в устройстве, состоящем из электродной системы, электронного и вычислительного блоков. В электродной системе неполяризующиеся электроды расположены с двух сторон листа земляники. Электронный блок предназначен для регистрации импеданса растительной ткани. Вычислительный блок (ноутбук) осуществляет поиск частоты, на которой реактивная составляющая импеданса максимальна, и вычисляет по этим данным диагностический параметр. Устройство функционирует под управлением программы регистрации реактивной составляющей импеданса растительной ткани и программы определения диагностического параметра. Для оценки точности устройства проведено сравнение значений диагностического параметра, полученных разработанным устройством и прецизионным анализатором импеданса WK 6505B. Значения параметра составили 1594 и 1574 пФ соответственно.

**Ключевые слова:** земляника садовая, пятнистости, диагностика, импедансная спектроскопия, электрическая эквивалентная схема, емкость клеточных мембран, портативное диагностическое устройство

## Development of a device for diagnostics of garden strawberry spot diseases

✉ Mineev V.V.<sup>1</sup>, Yolkin O.V.<sup>1</sup>, Aleynikov A.F.<sup>1,2</sup>, Morozov V.B.<sup>1</sup>, Richter V.A.<sup>1</sup>

<sup>1</sup>Siberian Federal Scientific Centre of Agro-BioTechnologies of the Russian Academy of Sciences  
Krasnoobsk, Novosibirsk region, Russia

<sup>2</sup>Novosibirsk State Technical University  
Novosibirsk, Russia

✉ e-mail: mineevfti@yandex.ru

Symptoms of garden strawberry leaf spot disease caused by phytopathogenic fungi are described. The impossibility of their identification by visible signs in the initial stage of the lesion is shown. Early

diagnosis is possible using antibody-based methods with phytopathogen antigens, molecular assays and aptamer-based methods. However, there are a number of difficulties in using them. To create a portable means of early diagnosis, methods based on the detection of electrical changes in plant leaf tissues as a result of fungal pathogen attack have been proposed: the method of electrical impedance spectroscopy and the method of electrical equivalent circuits. The methods allow determining a diagnostic parameter, the condenser capacitance modeling the capacitance of leaf plant cell membranes. It has been found that condenser capacitance values decrease as the degree of strawberry leaf lesion increases. The proposed methods are realized in a device consisting of an electrode system, electronic and computing units. In the electrode system, non-polarizing electrodes are located on both sides of the garden strawberry leaf. The electronic unit is designed to record the plant tissue impedance. The computing unit (laptop) searches for the frequency at which the reactive component of the impedance is maximum and calculates the diagnostic parameter from these data. The device operates under the control of a program for recording the reactive component of plant tissue impedance and a program for determining the diagnostic parameter. To evaluate the accuracy of the device, the values of the diagnostic parameter obtained by the developed device and the precision impedance analyzer WK 6505B were compared. The values of the parameter were 1594 and 1574 pF, respectively.

**Keywords:** garden strawberry, spotting, diagnostics, impedance spectroscopy, electrical equivalent circuit, cell membrane capacity, portable diagnostic device

**Для цитирования:** Минеев В.В., Ёлкин О.В., Алейников А.Ф., Морозов В.Б., Рихтер В.А. Разработка устройства для диагностики пятнистостей земляники садовой // Сибирский вестник сельскохозяйственной науки. 2024. Т. 54. № 10. С. 128–140. <https://doi.org/10.26898/0370-8799-2024-10-13>

**For citation:** Mineev V.V., Yolkin O.V., Aleynikov A.F., Morozov V.B., Richter V.A. Development of a device for diagnostics of garden strawberry spot diseases. *Sibirskii vestnik sel'skokhozyaistvennoi nauki = Siberian Herald of Agricultural Science*, 2024, vol. 54, no. 10, pp. 128–140. <https://doi.org/10.26898/0370-8799-2024-10-13>

#### Конфликт интересов

Авторы заявляют об отсутствии конфликта интересов.

#### Conflict of interest

The authors declare no conflict of interest.

#### Благодарность

Работа поддержана бюджетным проектом СФНЦА РАН № 0533-2024-0004.

#### Acknowledgments

This work was supported by the budgetary project of SFSCA RAS No. 0533-2024-0004.

## INTRODUCTION

Garden strawberry holds a significant share in global berry production. In 2017, it accounted for 72% of the total berry harvest worldwide (9.7 million tons out of 13.4) [1]. Strawberries ripen early and contain a complex of biologically active and easily digestible substances essential for humans [2, 3]. Properties such as the ability for rapid vegetative propagation, early fruiting, high profitability and yield, and adaptability allow strawberries to be cultivated in various soil and climatic zones [4]. The infection of cultivated plantations by fungal diseases is one of the main factors reducing the volume of garden strawberry production [5, 6]. The most common fungal diseases of garden strawberries are *Ramularia* leaf spot (white spot), brown spot, and angular

leaf spot [7]. The main causative agents of these leaf spots are fungi – *Ramularia tulasnei* Sass, *Mycosphaerella fragariae*, *Marssonina potentillae* (Desm.), *Dendrophoma obscurans* [8].

For successful control of diseases, it is necessary to carry out their detection and accurate identification of the species of phytopathogenic fungi. The need for their identification is due to the fact that various chemical and biological preparations are used to control specific fungal diseases: fungicides, peptides [9, 10]. Early diagnosis is of great importance: the earlier to take appropriate measures to protect plants, the greater the chances to reduce the range of a particular fungal disease. Otherwise, the plant may die or it will be necessary to increase the dose of fungicides during protective measures, which

leads to the accumulation of highly toxic organic compounds in the environment. At the same time, the quality of strawberry berries, which are usually consumed fresh, will be reduced [11].

Traditional methods are unable to provide an early diagnosis. This is because symptoms do not appear immediately after plant infection during the incubation period. For example, when identifying leaf spots on garden strawberries based on external visible signs in the initial stage of infection, the spots that appear on the surface of the plant's leaves are small (less than 1 mm) and similar in shape and color to all identifiable leaf spots. Additionally, similar damage can be caused by other microorganisms associated with viral and bacterial diseases of garden strawberries, as well as environmental factors such as low and high temperatures, and chemical damage from excessive mineral fertilizers. Characteristic symptoms of leaf spots appear much later when the spots increase in size. In the case of white spot, the central areas of the spots turn white and are surrounded by a dark brown or purple border. In brown spot, numerous shiny black pads containing fungal spores appear on the upper side of the leaf. A distinctive feature of angular leaf spot is the presence of a border around the spot on the lower side of the leaf, which is absent in brown spot. Isolating the fungus into a pure culture on a nutrient medium, obtaining sporulation, and then identifying the fungus under a microscope require significant time. Moreover, not all parasitic fungi can be cultured on artificial nutrient media; often, the presence of living host plant tissues is required.

Early detection of the pathogens causing leaf spots in garden strawberries is possible using the methods that have been rapidly developing recently, based on the interaction of antibodies with antigens of phytopathogens, as well as molecular analysis methods: enzyme-linked immunosorbent assay (ELISA), polymerase chain reaction (PCR), immunochromatographic assay

(ICA), and their modifications<sup>1</sup>. However, there are also a number of difficulties in their practical application. ELISA-based methods are widely used for detecting plant viruses and less frequently for identifying fungi and bacteria. PCR-based methods allow the detection of even a single fungal spore in the analyzed sample, which is an advantage but also a disadvantage, as it increases the requirements for sterility. ICA technologies have low sensitivity and specificity for some pathogens. New solutions based on aptamers (oligonucleotide molecules with the important property of strong and specific binding to target molecules) are known [12]. An example of a device for collecting soybean rust spores and subsequent detection using aptamers is described in [13]. However, the main factor limiting the practical application of all modern methods for diagnosing plant diseases is their high cost. Therefore, the task of developing a simpler and more affordable rapid diagnostic method for garden strawberry diseases is relevant.

When selecting the method, we were guided by the fact that all the methods of diagnostics of plant diseases are based on detection of either the phytopathogen itself or on determination of the changes occurring in the organisms of the pathogen and the host plant during their interaction. To determine a more effective method of diagnostics of fungal diseases, patent and information studies were conducted. It was revealed that the consequences of the attack of fungi-pathogens on plants are mechanical and chemical in nature. Mechanical impact consists in the rupture of the wax layer on the surface of leaves, the outer walls of the epidermal cells, as well as cytoplasmic membranes (plasmalemma) surrounding the protoplast of cells, due to high turgor pressure formed by filamentous formations - hyphae of fungal mycelium in the intercellular space of plant tissue [14]. Chemical action consists in the synthesis and release of a large number of different enzymes and elicitors

<sup>1</sup> Fedorenko V.F., Mishurov N.P., Nemenushchaya L.A. Perspective technologies of diagnostics of the agricultural plant pathogens: scientific analytical review. Moscow: Rosinformagrotekh, 2018, 68 p.

(elicitors are exometabolites of the pathogen that bind to the host receptor and trigger a defense reaction). Depolymerase enzymes cleave high-molecular-weight polymers unable to pass through cell membranes to oligo- and monomers used as nutrient substrates<sup>2</sup>. Other enzymes are able to cleave cell wall (CW) components. In response, the plant produces inhibitors of these enzymes, and low molecular weight products of CW degradation (oligosaccharides, etc.) are signaling molecules that trigger defense mechanisms. Elicitors “turn on” the synthesis of phytoalexins by plant cells, which slow down the synthesis of fungal pathogen enzymes and its growth<sup>3</sup>. Secondary metabolites are never present in a healthy plant and can be used for diagnostic purposes as markers of infection that can be detected, for example, by biochemical analysis. As a result of the impact of fungi-pathogens on plants the electrical properties of the plants are also changed. There are changes in the content of calcium, sodium, potassium ions and protons in the cytosol, depolarization of plasmalemma and tonoplast, as well as changes in the parameters of the transport system of the plasma membrane<sup>4</sup>. From the point of view of express diagnostics, electrical changes are of greater interest than chemical changes, since they can be detected immediately after their occurrence, for example, by electrical impedance spectroscopy (EIS) [15]. In this case, changes in the frequency dependences of the active part of the complex impedance of plant tissue reflect changes in the ion content and conductivity of the transport system, and reactive - changes in polarization and capacitance of cell membranes. The studies

carried out by us in the previous years have also confirmed that these changes are also present when strawberry leaves are affected by garden spots (magnitude of extremum of the reactive component, frequency of extremum, dispersion coefficient)<sup>5</sup>.

The method of equivalent electrical circuits is a promising direction, as it allows to reduce the influence of electrodes and to obtain electrical parameters of cellular structure: equivalents of electrical capacitance of plant cell membranes and electrical resistance of intercellular and intracellular fluids, which can be used to assess the state of plant physiology and pathology<sup>6</sup>.

The purpose of the research is to substantiate a specific equivalent electrical circuit as a model of electrical properties of garden strawberry leaves and the principle of obtaining bioimpedance parameters necessary for determining the equivalent electrical capacitance of plant cell membranes, and to create on this basis a device for strawberry leaf spot diagnosis.

## MATERIAL AND METHODS

The work is based on the methods of EIS and equivalent electrical circuits. The method of equivalent electrical circuits is used to determine the diagnostic parameter, i.e. capacitance of the capacitor modeling the capacitance of plant cell membranes of garden strawberry leaves; the EIS method is used to obtain data for calculating the value of the diagnostic parameter.

The choice of a specific electrical equivalent circuit of bioimpedance of plant tissues of strawberry leaves and the methodology for calculating its parameters was made in favor of the

<sup>2</sup>Dyakov Yu.T., Elansky S.N. General phytopathology: textbook for academic bachelor's degree. Moscow: “Yurait” Publishing House, 2016, 230 p.

<sup>3</sup>Sokolov Yu.A. Elicitors and their application // Proceedings of the National Academy of Sciences of Belarus, Chemical Series, 2014, N 4, pp. 109–121.

<sup>4</sup>Tarchevsky I.A. Effect of elicitors on ionic fluxes and electrical potentials of plants // Vestnik of Lobachevsky University of Nizhni Novgorod, 2001, pp. 60–63.

<sup>5</sup>Patent RU 2714324 MPC A01G 7/00. Method of detection of fungal diseases of garden strawberry / A.F. Aleynikov, V.V. Mineev. Mineev. Appl. 2019.07.01; publ. 14.02.2020.

<sup>6</sup>Zuev A.L., Mishlanov V.Yu., Sudakov A.I., Shakirov N.V., Frolov A.V. Equivalent electric models of biological objects // Russian Journal of Biomechanics, 2012, vol. 16, N 1 (55), pp. 110–120.

circuit (see fig. 1) and the methodology<sup>7</sup> on the basis of the following:

– the proposed scheme and methodology have been tested by the authors on plant tissues specifically;

– the method of calculating the circuit parameters is relatively simple. Thus, to calculate the capacitance of the capacitor  $C_2$ , modeling the capacitance of cell membranes of strawberry leaves, two parameters of the frequency response of the reactive component of the bioimpedance of plant leaf tissues are sufficient: the maximum value of the reactive resistance  $X_{s\ max}$  and the corresponding value of the characteristic frequency  $f_{\max}$ ;

– for hardware realization of  $X_{s\ max}$  and  $f_{\max}$

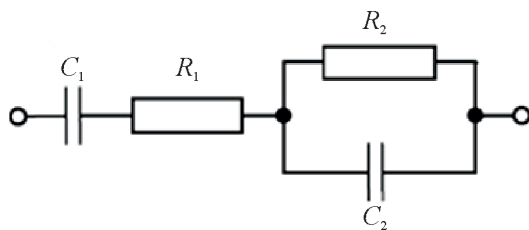

**Рис. 1.** Эквивалентная электрическая схема замещения растительной ткани листа земляники садовой:  $C_1$  – конденсатор, моделирующий емкость двойного электрического слоя на границе раздела металлических измерительных электродов и листа земляники;  $R_1$  – резистор, моделирующий сопротивление двойного электрического слоя на границе раздела металлических измерительных электродов и листа земляники;  $C_2$  – конденсатор, моделирующий емкость мембран растительных клеток листьев земляники;  $R_2$  – резистор, моделирующий сопротивления межклеточной и внутриклеточной жидкостей растительной ткани листьев земляники

**Fig. 1.** Equivalent electrical circuit for replacing plant tissue of a garden strawberry leaf:  $C_1$  – a condenser modeling the capacitance of a double electric layer at the interface of metal measuring electrodes and a garden strawberry leaf;  $R_1$  – a resistor modeling the resistance of the double electrical layer at the interface between metal measuring electrodes and a garden strawberry leaf;  $C_2$  – a condenser simulating the capacitance of the membranes of plant cells of garden strawberry leaves;  $R_2$  – a resistor modeling the resistance of intercellular and intracellular fluids of plant tissue of garden strawberry leaves

parameters determination there is a modern element base in the form of microcircuits, allowing to create devices in portable design;

– as a result of our experimental studies of garden strawberry varieties Tsaritsa and Brighton it was revealed that the capacitance values of capacitor  $C_2$ , modeling the capacitance of plant cell membranes, decreases as the degree of strawberry blotch damage increases and depends on both the degree of damage and the type of fungal disease.

Capacitor capacitance  $C_2$  is calculated by the formula (1) (see footnote 7). The parameters  $X_{s\ max}$  and  $f_{\max}$  are obtained from the experimentally obtained frequency response of the reactive component of bioimpedance by the discrete Fourier transform method, implemented in the impedance converter chip AD5933 of the company ANALOG DEVICES<sup>8</sup>.

$$C_2 = \frac{79577}{f_{\max} X_{s\ max}}, \text{ пФ}, \quad (1)$$

where  $X_{s\ max}$  – maximum value of reactance  $X_s$ , kOhm;  $f_{\max}$  – characteristic frequency value  $f$ , on which the value of reactance is equal to  $X_{s\ max}$ , kHz.

Functional diagram of AD5933 is shown in fig. 2. The microcircuit requires a control device (microcontroller or PC) to function. Control and information exchange with the AD5933 chip is carried out using the I2C bus.

This microcircuit uses a digital signal processing method both for generating the test harmonic voltage and for analyzing the current flowing through the sample under study—the plant tissue of a strawberry leaf (bioimpedance  $Z_x$ ). The alternating current signal with a specified frequency is generated by a built-in direct digital synthesizer (DDS), which includes a 27-bit phase quantization register, clocked either from an external source or from an internal 16 MHz oscil-

<sup>7</sup>Golev I.M., Sanin V.M., Titov S.A., Korotkov L.N. Electrical equivalent circuit of biological objects of plant origin // Bulletin of VSTU, 2013, vol. 9, N 4, pp. 26–29.

<sup>8</sup>Obraztsov S.A., Troitskiy Yu.V. Precision impedance converter AD5933 // Modern Electronics, 2009, N 9, pp. 12–15.



Рис. 2. Функциональная схема AD5933

Fig. 2. AD5933 Functional diagram

lator. After passing through the digital-to-analog converter (DAC), operational amplifier (OA), and the plant tissue of the strawberry leaf  $Z_x$ , the signal is sequentially fed to the input amplifier (IA), programmable amplifier (PA), low-pass filter (LPF), where sampling noise is eliminated, and then digitized using a 12-bit ADC. Next, a discrete Fourier transform is performed to obtain the real (active) and imaginary (reactive) parts of the bioimpedance  $Z_x$ , which become available for reading via the I2C bus by an external control device from the registers  $RgR(f)$  and  $RgI(f)$ . There is also the possibility of frequency spectrum registration with a programmable step, i.e., implementing the EIS method.

## RESULTS AND DISCUSSION

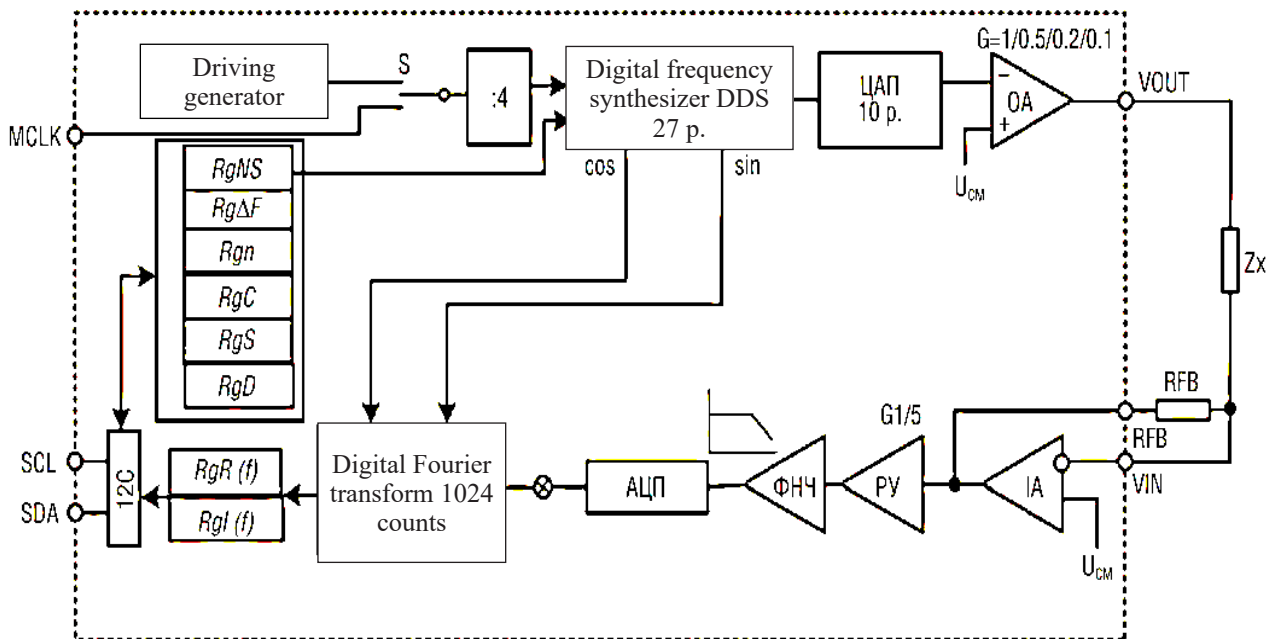
The considered methods are realized as a portable device in the following composition:

- electrode system;
- electronic unit for registration of frequency dependence of the reactive component of plant tissue impedance;
- computational block for finding the maximum of the reactive component of impedance

$X_s$  max, characteristic frequency  $f_{max}$  and calculation of capacitance of capacitor  $C_2$ , modeling the capacitance of cell membranes of strawberry leaves;

– appropriate software.

The photo of the designed and manufactured electrode system is shown in fig. 3.

The design features a two-sided arrangement of electrodes relative to the strawberry leaf. The H124SG electrodes from COVIDIEN (USA), of the 'button' type, are attached to a connector from Neurosoft (Russia), equipped with a cable. The diameter of the electrodes has been reduced through mechanical processing from 8 mm to 5 mm so that they can be positioned between the veins of the strawberry leaf. The connectors are attached to the jaws of a clothespin-type clamp using adhesive. The jaws of the clamp are trimmed so that the surfaces of the electrodes are parallel when in contact with the strawberry leaf. The clamping force is provided by a spring.

To reduce the contact resistance between the electrodes and the surface of the leaf plate, the electrodes are lubricated with electrically conductive electrode gel. Thin-walled fluoroplastic

rings limit the flow of electrode gel when the electrodes are pressed against the strawberry leaf. Thin fluoroplastic plates electrically insulate the metal surface of the connectors in case of accidental contact with the conductive gel. One of the plates has a stopper with a pointed end. The limiter provides a constant gap between the electrodes due to the stop in the opposite plate through a minor puncture of the strawberry leaf. Extremum  $X_s$  max and  $f_{max}$  parameters depend on the type of fungal disease, the degree of damage and the electrode system used. In this regard, for the development of the electronic unit, the possible ranges of their values were determined experimentally by recording the frequency dependences of the reactive impedance  $X_s$  of healthy and spotted leaf tissue of several strawberry varieties. Determination was carried out by a precision impedance analyzer WK 6505B (Wayne Kerr Electronics, Great Britain), included in the "State Register of Measuring Instruments of the Russian Federation" and having a wide range of electrical resistance measurement from 0.01

mOhm to 2 GOM with an error of no more than  $\pm 0.05\%$  in the frequency range from 20 Hz to 5 MHz with a frequency setting error of  $\pm 0.005\%$ , and the developed electrode system (see fig. 3). It is established that the electronic unit should provide registration of the reactive resistance  $X_s$  from 15 to 50 kOhm in the frequency range  $f$  from 400 to 4000 Hz.

The circuit diagram of the electronic block based on the impedance converter AD5933, developed taking into account the recommendations of ANALOG DEVICES, is shown in fig. 4.

The PIC16F876A microcontroller (not shown in fig. 4) is used as a control device. Since the lower boundary of the recorded frequency range is less than 1 kHz, the digital synthesizer DDS (see fig. 3) is clocked at a reduced frequency of 1 MHz from an external oscillator assembled on inverters U5 and U6.

To minimize additive error, the output of operational amplifier OA (see fig. 3) is connected to the input of the voltage repeater U4A AD8606 with low output impedance. To minimize the error, calibration (determination of the gain of the entire recording path and systematic additional phase shift of amplifiers OA, IA and RU) is also provided. For this purpose, a resistor of known nominal value is connected by a switch instead of the analyzed sample  $Z_x$  (not shown in fig. 4).

The external view of the electronic unit is shown in fig. 5.

At this stage, a mobile PC (laptop) was used as a computing unit. The software consisting of two programs was developed for the functioning of the device:

- program for registration of the reactive component of plant tissue impedance as a function of frequency, which provides the formation of a sequence of commands according to the algorithm of the AD5933 chip and the transfer of registration data to the computing unit;
- programs for determining the diagnostic parameter – capacitance of capacitor  $C_2$ , modeling the capacitance of cell membranes of strawberry leaves.

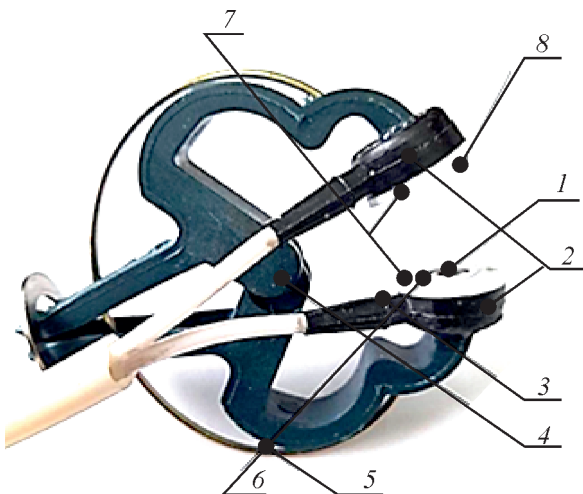

**Рис. 3.** Внешний вид электродной системы:  
1 – электроды; 2 – коннекторы; 3 – губки; 4 – зажим «прищепка»; 5 – пружина; 6 – кольца фторопластовые; 7 – пластинки фторопластовые; 8 – ограничитель

**Fig. 3.** Appearance of the electrode system:  
1 – electrodes; 2 – connectors; 3 – sponges; 4 – clothespin clip; 5 – spring; 6 – fluoroplastic rings; 7 – fluoroplastic plates; 8 – limiter

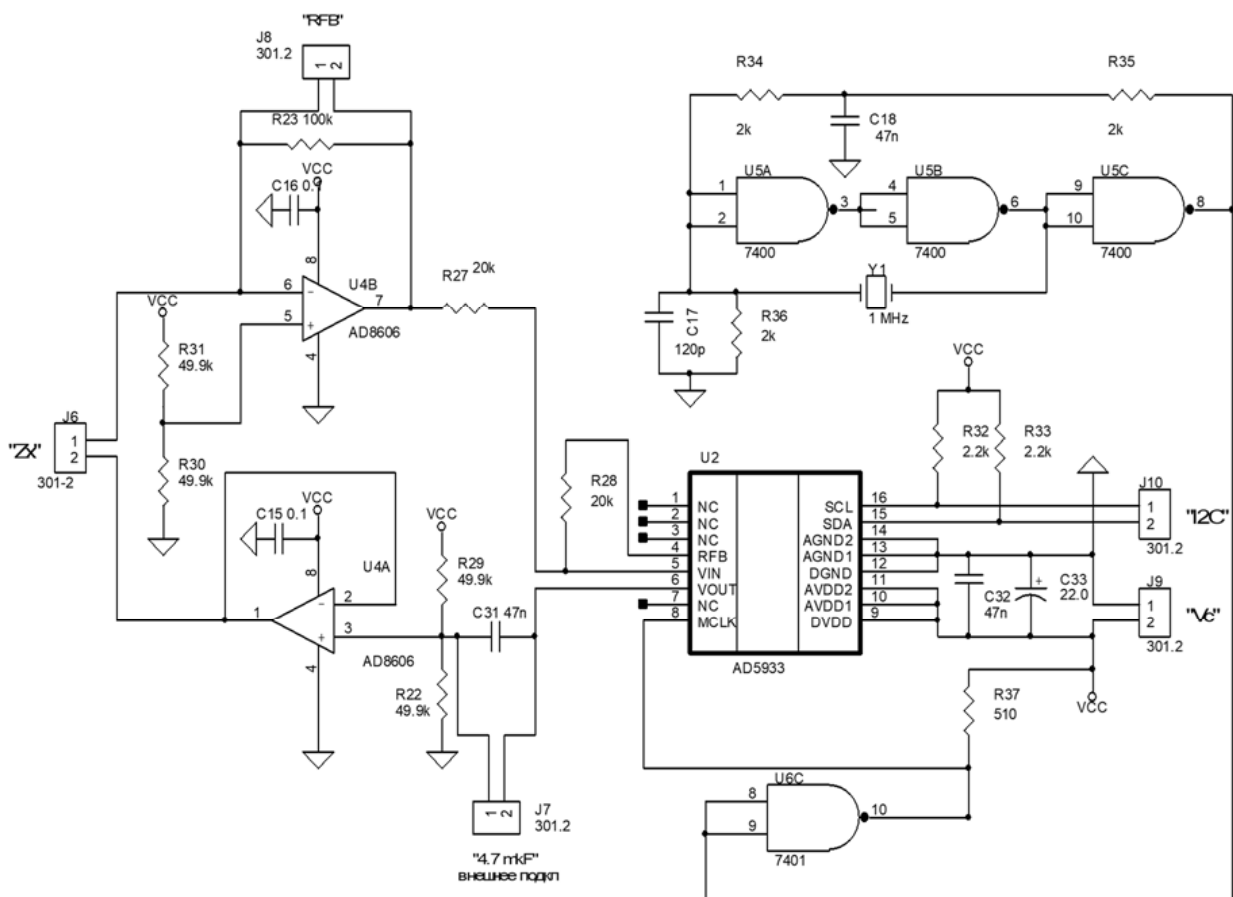

**Рис. 4.** Принципиальная схема электронного блока  
**Fig. 4.** Electronic unit circuit diagram

The program of reactive impedance component registration provides initialization of AD5933 chip and registration process, namely:

- writing the value of the initial frequency to the  $RgNS$  register;
- writing the number of frequency increments to the  $Rgn$  register;
- recording the value  $Rg\Delta F$  of the frequency increment;
- loading commands into the control register  $RgC$ ;
- input of the delay time introduced by the elements of the registration circuit into the register  $RgD$ ;
- control of the current state by reading the contents of the status register  $RgS$ ;
- output signal level setting;
- switching the chip to on state;
- initialization of the DDS oscillator with the initial frequency;

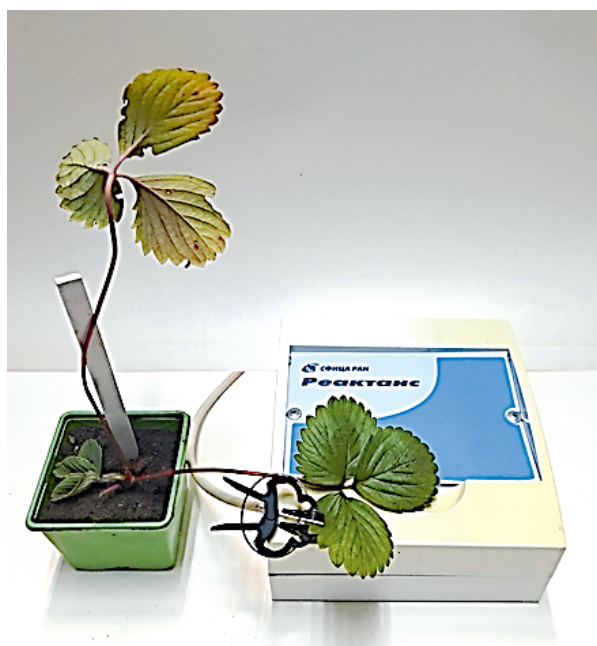

**Рис. 5.** Внешний вид электронного блока с электродной системой  
**Fig. 5.** Appearance of the electronic unit with the electrode system

- start registration at the initial frequency;
- transfer of real and imaginary parts of the immittance components from registers  $RgR(f)$  and  $RgI(f)$ , respectively, to the computing unit;
- transition to the next frequency;
- end of measurements.

The program for determining the diagnostic parameter finds the maximum value  $Xs_{max}$  from the array of values of reactive components of impedance  $X_s$ , determines the corresponding value of characteristic frequency  $f_{max}$  and by formula (1) calculates the value of capacitor capacitance  $C_2$ , which is displayed on the PC screen.

After debugging of the device, a comparative registration of the frequency dependence of the

reactive impedance of plant tissue of strawberry leaves of the Festivalnaya variety was carried out using a precision impedance analyzer WK 6505B and the developed device (see figs. 6, 7). To exclude random error caused by the contact parameters  $C_1$  and  $R_1$  (see fig. 1), which depend on the force of the electrodes pressed against the leaf, leaf morphology, and the area of contact between the electrode and the leaf, the registration was carried out at the same point of the leaf plate without detaching it from the electrode system by connecting the electrode leads first to the WK 6505B analyzer and then to our test device. Thus, the frequency characteristics of one and the same RC-two-pole were registered. In this case, the error in estimating the capacitance

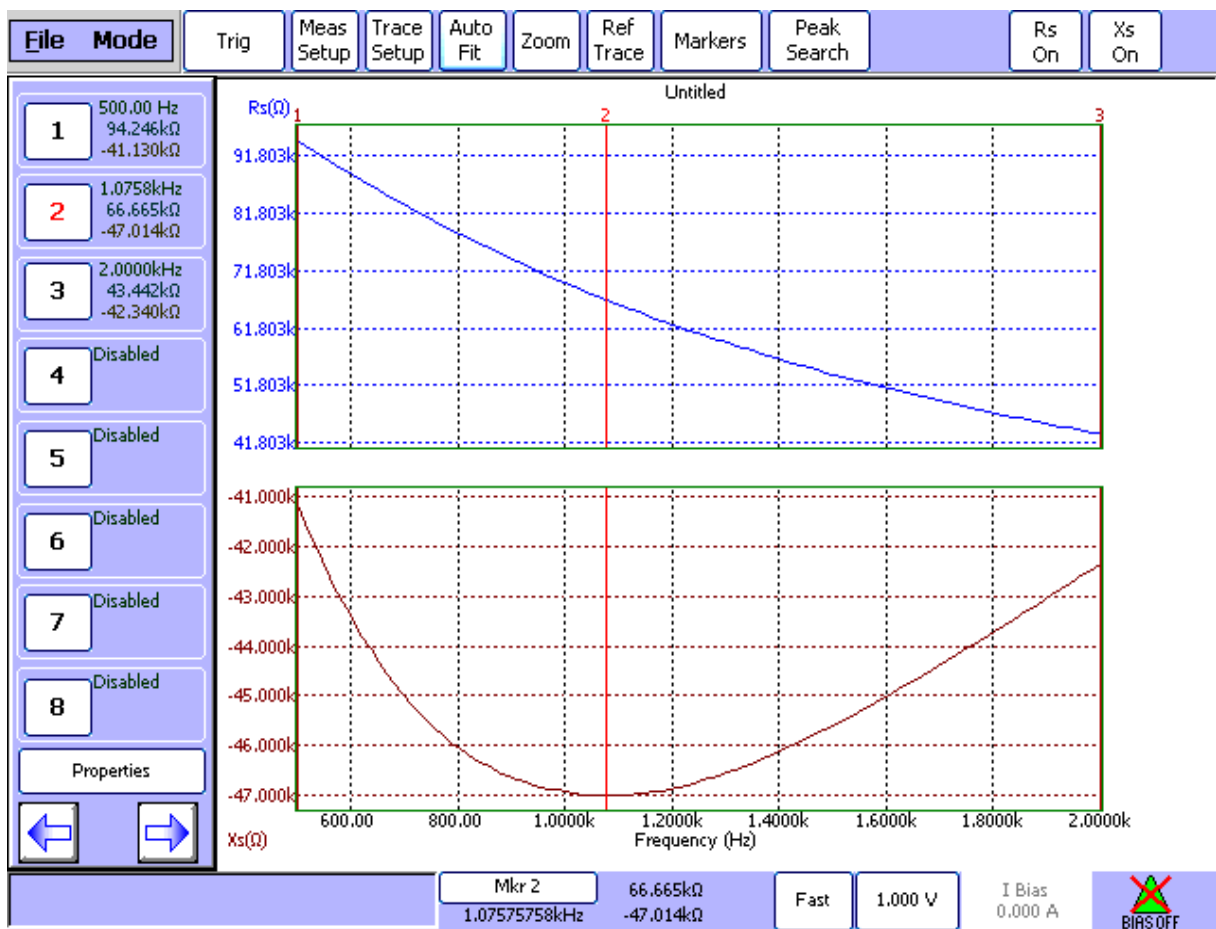

**Рис. 6.** Зависимость реактивного сопротивления  $X_s$  растительной ткани листа земляники сорта Фестивальная от частоты  $f$  (нижний график), полученная анализатором импеданса WK 6505B

**Fig. 6.** Dependence of reactance  $X_s$  of strawberry leaf tissue of the Festivalnaya variety on the frequency  $f$  (the lower graph) obtained with an impedance analyzer WK 6505B

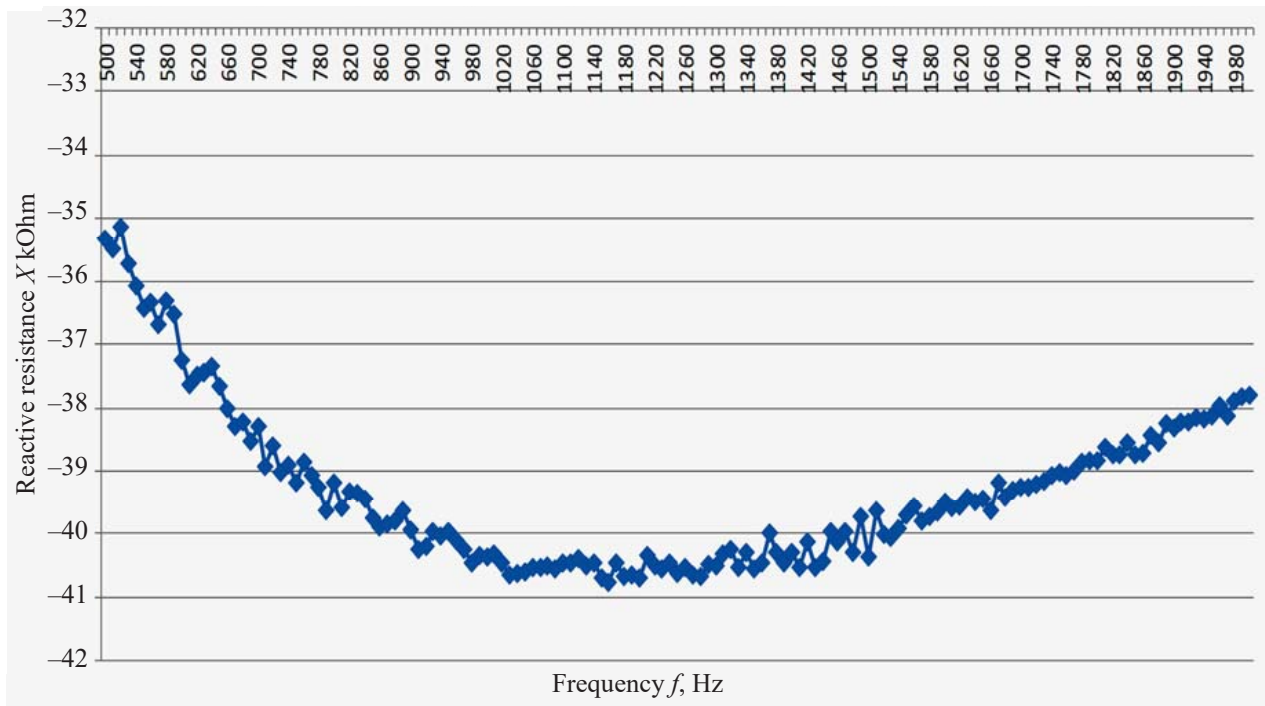

**Рис. 7.** Зависимость реактивного сопротивления  $X_s$  растительной ткани листа земляники сорта Фестивальная от частоты  $f$ , полученная разработанным устройством

**Fig. 7.** Dependence of reactance  $X_s$  of strawberry leaf tissue of the Festivalnaya variety on the frequency  $f$  obtained with the developed device

of capacitor  $C_2$  depends only on the error in determining the parameters  $X_s$  max and  $f_{max}$  (see formula 1). Since the accuracy of determination of these parameters by the WK 6505B analyzer is rather high ( $\pm 0,05$  and  $\pm 0,005\%$ , respectively), the estimation obtained with the WK 6505B analyzer can be taken as a valid one.

The values of the diagnostic parameter - capacitance of capacitor  $C_2$ , modeling the capacitance of leaf cell membranes, obtained from the results of registration of changes in the reactance  $X_s$  of plant tissue from frequency  $f$  (see fig. 6, 7) by calculation according to the formula (1), were 1574 and 1594 pF, respectively. The difference in the results is 1.3%.

## CONCLUSIONS

1. The necessity of express assessment of fungal diseases of garden strawberry with the help of portable technical means in field conditions is shown.

2. Methods based on detection of electrical changes in plant tissues of garden strawberry leaves as a result of fungi-pathogen attack are justified for realization of the portable device: EIS method and the method of electrical equivalent circuits.

3. On the basis of experimental studies, an electrical equivalent circuit in the form of a resistive-capacitive bipolar and a method of calculating its parameters for describing the electrical properties of plant tissues of garden strawberry leaves are proposed.

4. An electrode system has been developed that provides a constant gap between the electrodes located on the upper and lower sides of the strawberry leaf, as well as a constant area of contact between the electrode gel and the leaf surface.

5. On the basis of impedance converter AD5933 an electronic block for registration of frequency dependence of reactive component of

plant tissue impedance was developed; on the basis of mobile PC (laptop) – a computing block for searching the maximum of reactive component of impedance, characteristic frequency and calculation of diagnostic parameter – capacitance of the capacitor modeling the capacitance of cell membranes of strawberry leaves.

6. When determining the diagnostic parameter – capacitance of the capacitor modeling the capacitance of leaf cell membranes – by the developed device and precision impedance analyzer WK 6505B, the difference in the results was as follows 1,3%.

### СПИСОК ЛИТЕРАТУРЫ

1. *Ожерельев В.Н., Ожерельева М.В., Гринь А.М., Сомин В.В.* Динамика производства ягод земляники садовой по странам мира // Вестник Брянской государственной сельскохозяйственной академии. 2019. № 4 (74). С. 60–66.
2. *Жбанова Е.В., Лукьянчук И.В., Миронов А.М.* Витаминная и антиоксидантная ценность плодов сортов и отборных форм земляники селекции ФГБНУ «ФНЦ им. И.В. Мичурина» // Известия Тимирязевской сельскохозяйственной академии. 2019. № 6. С. 36–48. DOI: 10.34677/0021-342x-2019-6-36-48.
3. *Брюхина С.А., Трунов Ю.В., Медеяева А.Ю., Коршунов А.Ю.* Продуктивность и качество ягод земляники садовой в условиях Тульской области // Вестник Мичуринского государственного аграрного университета. 2023. № 2 (73). С. 24–28.
4. *Салимова Р.Р.* Оценка гибридов земляники садовой по хозяйственно ценным признакам // Вестник Мичуринского государственного аграрного университета. 2023. № 2 (73). С. 87–90.
5. *Юдин А.А., Павлова Е.В., Красильникова Е.В., Моторина В.А.* Оценка устойчивости сортов земляники садовой к основным болезням и вредителям // Известия Оренбургского государственного аграрного университета. 2022. № 2 (94). С. 62–66. DOI: 10.37670/2073-0853-2022-94-2-62-66.
6. *Savary S., Willocquet L.* The global burden of pathogens and pests on major food crops // *Nature Ecology and Evolution*. 2019. N 3. P. 430–439.
7. *Зубкова М.И., Насонова Г.В., Князев С.Д.* Особенности проявления основных болезней на землянике садовой // Вестник российской сельскохозяйственной науки. 2019. № 2. С. 41–44. DOI: 10.30850/vrsn/2019/2/41-44.
8. *Кащиц Ю.П.* Видовой состав фитопатогенных микромицетов листьев и ягод земляники садовой в Краснодарском крае и Республике Адыгея // Бюллетень Государственного Никитского ботанического сада. 2020. № 137. С. 23–28. DOI: 10.36305/0513-1634-2020-137-23-28.
9. *Зейналов А.С., Чурилина Т.Н.* Критерии эффективности современных методов защиты земляники от основных вредных организмов (обзорная статья) // Субтропическое и декоративное садоводство. 2020. № 74. С. 148–159. DOI: 10.31360/2225-3068-2020-74-148-159.
10. *Барашикова А.С., Рогожин Е.А.* Потенциал антимикробных пептидов растений для защиты сельскохозяйственных культур от возбудителей болезней // Вестник защиты растений. 2023. Т. 106. № 3. С. 120–136. DOI: 10.31993/2308-6459-2023-106-3-15980.
11. *Graeme J., Kettles V., Estrell L.* Food security in 2044: How do we control the fungal threat // *Fungal Biology*. 2019. Vol. 123 (8). P. 558–564.
12. *Коваленко А.А., Шаройко В.В., Казарцев И.А.* Перспективы применения аптамеров в защите растений и растениеводстве // Вестник защиты растений. 2022. Т. 105. № 1. С. 6–27. DOI: 10.31993/2308-6459-2022-105-1-15186.
13. *Krivitsky V., Granot E., Avidor Y., Borberg E.* Rapid Collection and Aptamer-Based Sensitive Electrochemical Detection of Soybean Rust Fungi Airborne Urediniospores // *ACS Sensor*. 2021. Vol. 6 (3). P. 1187–1198.
14. *Домрачева Л.И., Скугорева С.Г., Стариков П.А., Горностаева Е.А., Ашихмина Т.Я.* Микробы-антагонисты против фитопатогенных бактерий и грибов (обзор) // Теоретическая и прикладная экология. 2022. № 2. С. 6–14. DOI: 10.25750/1995-4301-2022-2-006-014.
15. *Wang Y.Q., Zhao P.F., Fan L.F., Zhou Q., Wang Z.Y.* Determination of water content and characteristic analysis in substrate root zone by electrical impedance spectroscopy // *Computers*

and Electronics in Agriculture. 2019. Vol. 156. P. 243–253.

## REFERENCES

1. Ozherel'ev V.N., Ozherel'eva M.V., Grin' A.M., Somin V.V. Dynamics of garden strawberry production all over the world. *Vestnik Bryanskoi gosudarstvennoi sel'skokhozyaistvennoi akademii = Vestnik of the Bryansk State Agricultural Academy*, 2019, no. 4 (74), pp. 60–66. (In Russian).
2. Zhanova E.V., Lukyanchuk I.V., Mironov A.M. Vitamin and antioxidant value of fruits of strawberry varieties and selected forms bred in I.V Michurin Federal scientific center. *Izvestiya Timiryazevskoi sel'skokhozyaistvennoi akademii = Izvestiya of Timiryazev Agricultural Academy*, 2019, no. 6, pp. 36–48. (In Russian). DOI: 10.34677/0021-342x-2019-6-36-48.
3. Bryukhina S.A., Trunov Yu.V., Medelyeva A.Yu., Korshunov A.Yu. Productivity and quality of strawberry berries under the conditions of the Tula region. *Vestnik Michurinskogo gosudarstvennogo agrarnogo universiteta = Bulletin of Michurinsk State Agrarian University*, 2023, no. 2 (73), pp. 24–28. (In Russian).
4. Salimova R.R. Evaluation of strawberry hybrids by economic and valuable characteristics. *Vestnik Michurinskogo gosudarstvennogo agrarnogo universiteta = Bulletin of Michurinsk State Agrarian University*, 2023, no. 2 (73), pp. 87–90. (In Russian).
5. Yudin A.A., Pavlova E.V., Krasil'nikova E.V., Motorina V.A. Evaluation of resistance of garden strawberry varieties to major diseases and pests. *Izvestiya Orenburgskogo gosudarstvennogo agrarnogo universiteta = Izvestia Orenburg State Agrarian University*, 2022, no 2 (94), pp. 62–66. (In Russian). DOI: 10.37670/2073-0853-2022-94-2-62-66.
6. Savary S., Willocquet L. The global burden of pathogens and pests on major food crops. *Nature Ecology and Evolution*, 2019, no. 3, pp. 430–439.
7. Zubkova M.I., Nasonova G.V., Knyazev S.D. Peculiarities of principal diseases manifestation on strawberry. *Vestnik rossiiskoi sel'skokhozyaistvennoi nauki = Vestnik of the Russian Agricultural Science*, 2019, no. 2, pp. 41–44. (In Russian). DOI: 10.30850/vrsn/2019/2/41-44.
8. Kashchits Yu.P. Species composition of phytopathogenic micromycetes of leaves and berries of garden strawberry in Krasnodar region and the Republic of Adygea. *Byulleten' Gosudarstvennogo Nikitskogo botanicheskogo sada = Bulletin of the State Nikitsky Botanical Gardens*, 2020, no. 137, pp. 23–28. (In Russian). DOI: 10.36305/0513-1634-2020-137-23-28.
9. Zeinalov A.S., Churilina T.N. Efficiency criteria of modern methods for protecting strawberries from the main pests (review). *Subtropicheskoe i dekorativnoe sadovodstvo = Subtropical and ornamental horticulture*, 2020, no. 74, pp. 148–159. (In Russian). DOI: 10.31360/2225-3068-2020-74-148-159.
10. Barashkova A.S., Rogozhin E.A. The potential of plant antimicrobial peptides for crop protection against diseases. *Vestnik zashchity rastenii = Plant Protection News*, 2023, vol. 106, no. 3, pp. 120–136. (In Russian). DOI: 10.31993/2308-6459-2023-106-3-15980.
11. Graeme J., Kettles V., Estrell L. Food security in 2044: How do we control the fungal threat. *Fungal Biology*, 2019, vol. 123 (8), pp. 558–564.
12. Kovalenko A.A., Sharoiko V.V., Kazartsev I.A. Prospects for the application of aptamers in plant protection and crop production. *Vestnik zashchity rastenii = Plant Protection News*, 2022, vol. 105, no. 1, pp. 6–27. (In Russian). DOI: 10.31993/2308-6459-2022-105-1-15186.
13. Krivitsky V., Granot E., Avidor Y., Borberg E. Rapid Collection and Aptamer-Based Sensitive Electrochemical Detection of Soybean Rust Fungi Airborne Urediniospores. *ACS Sensor*, 2021, vol. 6 (3), pp. 1187–1198.
14. Domracheva L.I., Skugoreva S.G., Starikov P.A., Gornostaeva E.A., Ashikhmina T.Ya. Microbes-antagonists against phytopathogenic bacteria and fungi (review). *Teoreticheskaya i prikladnaya ekologiya = Theoretical and applied ecology*, 2022, no. 2, pp. 6–14. (In Russian). DOI: 10.25750/1995-4301-2022-2-006-014.
15. Wang Y.Q., Zhao P.F., Fan L.F., Zhou Q., Wang Z.Y. Determination of water content and characteristic analysis in substrate root zone by electrical impedance spectroscopy, *Computers and Electronics in Agriculture*, 2019, vol. 156, pp. 243–253.

---

## ИНФОРМАЦИЯ ОБ АВТОРАХ

✉ **Минеев В.В.**, старший научный сотрудник; **адрес для переписки:** Россия, 630501, Новосибирская область, р.п. Краснообск, а/я 463; e-mail: mineevfti@yandex.ru

**Ёлкин О.В.**, кандидат технических наук, ведущий научный сотрудник

**Алейников А.Ф.**, доктор технических наук, профессор, главный научный сотрудник

**Морозов В.Б.**, научный сотрудник

**Рихтер В.А.**, научный сотрудник

## AUTHOR INFORMATION

✉ **Valery V. Mineev**, Senior Researcher; **address:** PO Box 463, Krasnoobsk, Novosibirsk Region, 630501, Russia; e-mail: mineevfti@yandex.ru

**Oleg V. Yolkin**, Candidate of Science in Engineering, Lead Researcher

**Alexander F. Aleynikov**, Doctor of Science in Engineering, Professor, Head Researcher

**Vladimir B. Morozov**, Researcher

**Vladimir A. Richter**, Researcher

*Дата поступления статьи / Received by the editors 09.07.2024*  
*Дата принятия к публикации / Accepted for publication 23.08.2024*  
*Дата публикации / Published 20.11.2024*



<https://doi.org/10.26898/0370-8799-2024-10-14>

УДК: 633.521:631.472.56

Тип статьи: оригинальная

Type of article: original

## Влияние органического вещества дерново-подзолистой почвы на урожайность и качество льнопродукции

Прудников В.А., (✉) Степанова Н.В., Фесько Д.Ю.

Республиканское научное дочернее унитарное предприятие «Институт льна»

Витебская область, Агродорок Устье, Республика Беларусь

(✉) e-mail: Natali1673@mail.ru

Изучено влияние органического вещества дерново-подзолистой среднесуглинистой почвы на урожайность и качество льнопродукции путем закладки вегетационно-полевого опыта. Исследования проведены в 2021–2023 гг. в северо-восточной части Республики Беларусь. Почва характеризовалась содержанием органического вещества 1,51–1,52 – 2,02–2,05 – 2,52–2,56%, повышенным содержанием подвижных форм фосфора (242–250 мг/кг почвы) и калия (216–232), средним – бора (0,56–0,62) и меди (2,7–2,9), низким – цинка (2,5–2,9 мг/кг почвы) при кислотности 5,4–5,5 рН<sub>кисл</sub>. Исследования проводили в засушливых условиях вегетации льна-долгунца 2021 г. (ГТК Селянинова 0,74), в слабо засушливых 2022 г. (ГТК 1,24) и экстремальных 2023 г. (ГТК мая – 0,08, июня – 0,68, июля – 3,71, периода вегетации – 1,63). Доказано положительное влияние органического вещества почвы на урожайность и качество льнопродукции. Повышение содержания органического вещества в почве от 1,5 до 2,0–2,5% увеличивало урожайность семян на 16–35% за счет увеличения коробочек (+22–39%) и семян на растении (+46–65%), тресты – на 10–33% за счет повышения технической длины стебля (+6–13%), волокна – на 14–37%, в том числе длинного – на 15–43%, за счет повышения количества и размера лубяных пучков (+5–20 и 5–28%), а также количества элементарных волокон в пучке (+10–15%) и их поперечного размера (+7–10%). Качество стланцевой тресты повышалось на 1–2 номера за счет увеличения в ней содержания длинной фракции волокна на 7–11% отн. и улучшения равномерности цвета на 16–21%. Повышение качества длинного трепаного волокна на 1 номер обусловлено увеличением его горстевой длины (+8–13%) и прочности (+3–8%).

**Ключевые слова:** лен-долгунец, органическое вещество почвы, урожайность, качество

## Influence of organic matter of sod-podzolic soil on the yield and quality of flax products

Prudnikov V.A., (✉) Stepanova N.V., Fesko D.Yu.

Republican Scientific Subsidiary Unitary Enterprise "The Institute of Flax"

Ustye agro town, Vitebsk region, Belarus

(✉) e-mail: Natali1673@mail.ru

The influence of organic matter of sod-podzolic medium loamy soil on the yield and quality of flax products was studied by means of vegetation and field experiment. The research was conducted in 2021–2023 in the north-eastern part of the Republic of Belarus. The soil was characterized by organic matter content of 1.51–1.52 – 2.02–2.05 – 2.52–2.56%, high content of mobile forms of phosphorus (242–250 mg/kg soil) and potassium (216–232), medium content of boron (0.56–0.62) and copper (2.7–2.9), and low content of zinc (2.5–2.9 mg/kg soil) with an acidity of 5.4–5.5 pH<sub>acid</sub>. The studies were conducted under drought conditions of fiber flax vegetation in 2021 (Selyaninov HTC 0.74), under slightly drought conditions in 2022 (HTC 1.24) and extreme conditions in 2023 (HTC May – 0.08, June – 0.68, July – 3.71, vegetation period – 1.63). The positive influence of soil organic matter on the yield and quality of flax products has been proved. Increasing the organic matter content in the

soil from 1.5 to 2.0 –2.5% improved seed yield by 16–35% due to an increase in bolls (+22–39%) and seeds per plant (+46–65%), flax straw – by 10–33% due to an increase in technical stem length (+6–13%), fiber – by 14–37%, including long fiber – by 15–43% by increasing the number and size of bast bundles (+5 – 20 and 5 –28%), as well as the number of elementary fibers in the bundle (+10 –15%) and their transverse size (+7 –10%). The quality of retted flax straw was improved by 1–2 numbers by increasing its content of long fiber fraction by 7–11% rd. and improving color uniformity by 16–21%. The increase in quality of long flax rolled and beaten tow by 1 number is due to an increase in its strick of flax length (+8–13%) and strength (+3–8%).

**Keywords:** fiber flax, soil organic matter, productivity, quality

**Для цитирования:** *Прудников В.А., Степанова Н.В., Фесько Д.Ю.* Влияние органического вещества дерново-подзолистой почвы на урожайность и качество льнопродукции // Сибирский вестник сельскохозяйственной науки. 2024. Т. 54. № 10. С. 141–148. <https://doi.org/10.26898/0370-8799-2024-10-14>

**For citation:** Prudnikov V.A., Stepanova N.V., Fesko D.Yu. Influence of organic matter of sod-podzolic soil on the yield and quality of flax products. *Sibirskii vestnik sel'skokhozyaistvennoi nauki = Siberian Herald of Agricultural Science*, 2024, vol. 54, no. 10, pp. 141–148. <https://doi.org/10.26898/0370-8799-2024-10-14>

#### Конфликт интересов

Авторы заявляют об отсутствии конфликта интересов.

#### Conflict of interest

The authors declare no conflict of interest.

#### Благодарность

Исследования осуществлены за счет средств бюджета Республики Беларусь и средств Республиканского научного дочернего унитарного предприятия «Институт льна».

#### Acknowledgements

The research was carried out at the expense of the budget of the Republic of Belarus and the funds of the Republican Scientific Subsidiary Unitary Enterprise “The Institute of Flax”.

## INTRODUCTION

The intensification of agriculture is associated with an increase in the areas under perennial legumes and leguminous crops, the cultivation of intermediate crops for fodder and green manure, but primarily with an increase in the volume of organic fertilizer application [1]. Soil organic matter creates and maintains the basic properties, functions, and regimes of soils, serves as a producer of CO<sub>2</sub> involved in photosynthesis, a source of macro- and microelements, and prevents erosion processes<sup>1</sup> [2, 3]. A powerful factor influencing the intensity of mineralization and humification processes of plant residues is

the tillage system [4–6] and the fertilization system<sup>2, 3</sup>.

The use of only mineral fertilizer system leads to the greatest losses of organic matter<sup>4</sup>. If up to 81.4 million tons of organic fertilizers (14 t/ha of arable land) were applied to the fields of the Republic of Belarus in the period 1986–1990 [7], in 2018–2022 – only 49.1 million tons (10 t/ha of arable land)<sup>5</sup>. In the total volume of organic matter entering the soil, the share of plant residues is 55% on average in Belarus, the share of organic fertilizers is 45% [7].

Under conditions of constantly increasing potential productivity of agricultural crops, soil

<sup>1</sup>Semyonov V.M., Kogut B.M. Soil organic matter. Moscow: GEOS, 2015, 233 p.

<sup>2</sup>Khaidukov K.P., Shevtsova L.K., Kuzmenko H.H. Influence of long-term application of different fertilizer systems on the content of mobile humus substances in sod-podzolic light loamy soil // Plodorodie, 2012, N 3 (66), pp. 11–13.

<sup>3</sup>Shevtsova L.K., Khaidukov K.P., Kuzmenko H.H. Transformation of organic matter of light loamy sod-podzolic soil under long-term application of fertilizers in flax crop rotation // Agricultural chemistry, 2012, N 10, pp. 3–12.

<sup>4</sup>Kuzmenko N.N. Monitoring of humus of sod-podzolic soil at application of different fertilizer systems // Modern Science Success, 2017, vol. 2, N 9, pp. 181–184.

<sup>5</sup>Agriculture of the Republic of Belarus. Statistical booklet / edited by I.V. Medvedeva. Minsk: Information and Computing Center of the National Statistical Committee of the Republic of Belarus, 2023, 36 p.

organic matter is an important factor in the formation of their high and stable yield<sup>6</sup> [8, 9]. It creates optimal root nutrition of plants, mitigates the negative effects of adverse climatic conditions, and ensures the full realization of the genetic potential of the variety.

The yield of agricultural crops depends more on the content of mobile humus substances, which are most affected by external factors, than on the amount of humus in the soil [10]. Signs of degradation of the qualitative composition of soil organic matter are especially noticeable on the indicators of the content of active components: mobile humus substances, the share of humic acids in their composition, the ability of soil organic matter to mineralization, the content of easily transformable organic matter.

In addition, organic matter is the only source of energy for the vital activity of soil microflora and biota. When there is a lack of fresh organic matter in the soil, soil microorganisms satisfy the need for carbon by decomposition of humus, affecting soil processes and fertility<sup>7,8</sup> [11]. This is especially important for long-staple flax, as the microbial community activity determines straw curing and the quality of the fiber produced.

The purpose of the research is to reveal the potential yield and quality of flax products in the cultivation of long-staple flax on soil with different content of organic matter.

## MATERIAL AND METHODS

The research was conducted in the north-eastern part of the Republic of Belarus on the experi-

mental field of RUE “Flax Institute” in dry conditions of flax growing season 2021 (Selyaninov HTC 0.74), in slightly dry 2022 (HTC 1.24) and extreme 2023 (HTC May – 0.08, June – 0.68, July – 3.71, growing season – 1.63). The period of straw retting in 2021 was set as optimal (HTC 1.53), in 2022 and 2023 – overwatered (HTC 1.85 and 2.16).

The vegetation and field experiment was laid according to the methodology of B.A. Dospekhov<sup>9</sup>. Fiber flax seeds were sown manually at a seed rate of 22 million seeds/ha with a row spacing width of 10 cm. Mineral fertilizers were applied: zinc – 1.0 kg a.i./ha, phosphorus – 60, potassium – 90 kg a.i./ha. The area of the registration plot was 1 m<sup>2</sup>, the repetition was four-fold. The sod-podzolic medium loamy soil was characterized by the content of organic matter 1.51–1.52 – 2.02 – 2.02 – 2.05 – 2.52–2.56%, high content of mobile forms of phosphorus (242–250 mg/kg of soil) and potassium (216–232), medium - boron (0.56–0.62) and copper (2.7–2.9), low - zinc (2.5–2.9 mg/kg of soil) with acidity 5.4– 5.5 pH<sub>кел</sub>.

The crops were cared for during the growing season according to the industry technological regulations for the cultivation of fiber flax<sup>10</sup>. Harvesting was carried out by manual cutting of stems, threshing of bolls and spreading of straw. The anatomical structure of the stem was studied by scanning electron microscopy on cross sections of the middle of the technical length (10 typical stems were sampled)<sup>11</sup>. The quality of flax raw material was determined according to state standards<sup>12, 13</sup>.

<sup>6</sup>Shang Q., Ling N., Feng X., et al. Soil fertility and its significance to crop productivity and sustainability in typical agroecosystem: a summary of long-term fertilizer experiments in China // *Plant and Soil*, 2014, N 381 (1–2), pp. 13–23. DOI: 10.1007/s11104-014-2089-6.

<sup>7</sup>Dobrovolskaya T.G., Zvyagintsev T.G., Chernov I.Yu. Role of microorganisms in ecological functions of soils // *Eurasian Soil Science*, 2015, N 9, pp. 1087–1096. DOI: 10.7868/S0032180X15090038.

<sup>8</sup>Khan K.S., Mack R., Castillo X. Microbial biomass, fungal and bacterial residues, and their relationships to the soil organic matter C/N/P/S ratios // *Geoderma*, 2016, vol. 271, pp. 115–123.

<sup>9</sup>Dospekhov B.A. Methodology of field experiment (with the basics of statistical processing of research results). Moscow: Kolos, 1979, 416 p.

<sup>10</sup>Industry regulations. Cultivation of long-staple flax. Typical technological processes. Minsk: RUE “Flax Institute”, 2019, 15 p.

<sup>11</sup>Andreeva I.I., Rodman L.S., Chichev A.V. Practicum on anatomy and morphology of higher plants. Moscow: Kolos, 2019, 144 p.

<sup>12</sup>STB 1194-2007. Linen flax straw. Requirements for harvesting. Date of introduction 01.07.2011. Minsk: State Standard of the Republic of Belarus, 2009, 12 p.

<sup>13</sup>STB 1195-2008. Long flax rolled and beaten tow. Technical conditions. Date of introduction: 01.11.2008. Minsk: State Standard of the Republic of Belarus, 2008, 18 p.

## RESULTS AND DISCUSSION

On average for 2021–2023 studies, when sowing fiber flax on soil with the content of organic matter of 1.5%, seed yield per 1 ha was 5.7 kg (see Table 1). At the same time, 1.8 bolls, 5.9 seeds in a boll and 10.7 seeds per plant were formed on the plant (see Table 2).

On the soil with organic matter content of 2.0–2.5%, seed yield increased significantly by 0.9–2.0 c/ha (16–35%) due to an increase in the number of bolls on the plant to 2.2–2.5 (22–39%), seeds in the boll to 7.1 (20%) and on the plant to 15.6–17.7 (46–65%). The weight of

1000 seeds in the experiment variants had a positive tendency to increase.

The straw yield was 30.8 c/ha on soil with an organic matter content of 1.5% at a technical stem length of 71 cm, fiber yield was 9.0, including long fiber – 6.0 c/ha. Increasing the content of soil organic matter to 2.0–2.5% influenced the technical stem height, increasing it by 6–13%. Straw yields increased by 3.0–10.3 c/ha (10–33%), fiber yields by 1.3–3.3 c/ha (14–37%), including long fiber yields by 0.9–2.6 c/ha (15–43%).

Seed yield was greatly influenced by the con-

**Табл. 1.** Влияние содержания органического вещества почвы на урожайность льнопродукции (среднее за 2021–2023 гг.)

**Table 1.** The influence of soil organic matter content on the yield of flax products (average for 2021–2023)

Soil organic matter content, %	Yield, c/ha			
	seeds	flax straw	fiber	
			total	long
1,5	5,7	30,8	9,0	6,0
2,0	6,6	33,8	10,3	6,9
2,5	7,7	41,1	12,3	8,6
LSD <sub>05</sub>	0,66 (0,53–0,75)	2,7 (2,2–3,6)	0,83 (0,76–0,92)	0,54 (0,47–0,60)
η, %:				
organic matter	79,1	24,3	28,2	20,1
weather conditions	8,2	71,4	60,4	55,0
interaction of factors	5,3	1,4	8,4	19,7

Note. η – share of factor influence on the yield of fiber flax.

**Табл. 2.** Влияние содержания органического вещества почвы на структуру урожая льна-долгунца (среднее за 2021–2023 гг.)

**Table 2.** The influence of soil organic matter content on the structure of fiber flax yield (average for 2021–2023)

Soil organic matter content, %	Stem length, cm		Number of bolls on a plant	Number of seeds		1000 seed weight, g
	total	technical		on a plant	in a boll	
1,5	71,0	57,7	1,8	10,7	5,9	4,91
2,0	74,7	61,0	2,2	15,6	7,1	4,94
2,5	78,3	65,0	2,5	17,7	7,1	5,06
LSD <sub>05</sub>	2,2 (1,7–3,0)	1,5 (0,93–2,1)	0,29 (0,18–0,46)	1,4 (1,3–1,6)	0,49 (0,35–0,73)	$F_{\phi} < F_{05}$

tent of organic matter in the soil with the share of the influence of this factor ( $\eta$ ) for the years of research 79%, while the yields of straw and fiber were influenced by the weather conditions of the year – 71 and 60%, respectively. The best conditions for the development of fiber flax and formation of flax products were formed in 2021 with the index of environmental conditions ( $I_j$ ) for seed yield of 0.2, straw yield – 9.9, the worst conditions – in 2023 with a negative value of the environmental index –0.1 and –7.9 respectively.

The increase in fiber yield is confirmed by the analysis of the anatomical structure of the flax stalk. On the soil with 1.5% of organic matter on average 26 bast bundles with a total area of 0.14 mm<sup>2</sup> (the share in the bast 48.3%) were formed in the stem (see Table 3). The bundle contained 23 elementary fibers with a cross-sectional area of 234.65 μm<sup>2</sup>/pcs. and a small size of their inside width of the lumen.

With an increase in soil organic matter content to 2.0–2.5% by increasing the bundle size by 5–28%, the number of bast bundles increased by 1.2–5.0 (5–20%), their total area in the bast by 0.02–0.08 mm<sup>2</sup> (14–57%), and their proportion in the bast by 4–11%. In the bundle, the number of elementary fibers increased by 2.4–3.5 (10–15%), their cross-sectional area by 17.38–24.03 μm<sup>2</sup> (7–10%).

Soil organic matter had a positive effect on the quality of flax stem straw, the average num-

ber of which increased from 1.50 on the soil with 1.5% organic matter to 1.67–1.83 on the soil with 2.0–2.5% organic matter (see Table 4). The main indicators of straw quality are the yield of long fiber fraction from straw, its color and uniformity of dyeing.

As the soil organic matter content increased from 1.5 to 2.0–2.5%, the 3-year average of the long fiber fraction in the flax straw increased from 19.0 to 20.3–21.2% (1.3–2.2%): in 2022 from 21.8 to 23.2–26.2% (1.4–4.4%), in 2023 from 14.3 to 17.6–19.9% (3.3–5.6%).

In 2022 and 2023, an increase in soil organic matter content from 1.5 to 2.0–2.5% increased the quality of retted flax straw from 1.75 to 2.00–2.50 and from 1.00 to 1.25–1.50 numbers (by 1–2 variety numbers), respectively. In 2021, a tall plant stand (up to 82 cm) was formed on the soil with an organic matter content of 2.5%, which could not withstand squall winds. As a result of root lodging of the plants, the quality of flax straw decreased by 1 number (from 1.75 to 1.50) compared to sowing flax on the soil containing 1.5–2.0% of organic matter.

The quality of long flax rolled and beaten tow is a set of physical and mechanical characteristics, which are expressed by the design number. The fiber obtained under the conditions of 2021–2023 had low and medium handful length (51–58 cm), high flexibility (49–53 mm) and increased strength (breaking load) (216–235 N).

**Табл. 3.** Характеристика структурных элементов луба льна-долгунца в зависимости от содержания органического вещества почвы

**Table 3.** Characteristics of the structural elements of fiber flax bast depending on the content of soil organic matter

Soil organic matter content, %	Bast fibre bundles				Elementary fibers			
	number	square		share in a bast, %	number in a bundle	cross-sectional area, μm <sup>2</sup>	size of the internal lumen, μm <sup>2</sup>	useful fiber area, μm <sup>2</sup>
		one bundle, μm <sup>2</sup> /pc.	total in a stem, mm <sup>2</sup>					
1,5	25,8	5478,11	0,14	48,3	23,1	234,65	11,88	222,77
2,0	27,0	5770,31	0,16	52,6	25,5	252,03	11,42	240,61
2,5	30,9	7018,31	0,22	59,5	26,6	258,68	15,20	243,48
$\bar{x} \pm Sx$	$27,90 \pm 0,54$	$6088,91 \pm 335,90$	$0,17 \pm 0,01$		$25,07 \pm 0,53$	$248,45 \pm 11,12$	$12,83 \pm 1,97$	$235,62 \pm 9,56$

**Табл. 4.** Влияние содержания органического вещества почвы на качество льняной стланцевой тресты и длинного трепаного волокна (среднее за 2021–2023 гг.)

**Table 4.** Influence of soil organic matter content on the quality of flax retted straw and long flax rolled and beaten tow (average for 2021–2023)

Performance characteristics of flax raw materials	Soil organic matter content, %		
	1,5	2,0	2,5
<i>Retted flax straw (STB 1194–2007)</i>			
Yield of total fiber from flax straw, % (V, %)	29,3 (11,0)	30,6 (11,7)	30,2 (15,5)
Long fiber yield from flax straw, % (V, %)	19,0 (21,5)	20,3 (13,9)	21,2 (15,0)
Fiber color index (V, %)	1,9 (16,6)	2,3 (19,9)	2,2 (19,8)
Number of percentage meters	169,0	189,3	195,7
Flax straw number	1,50	1,67	1,83
<i>Long flax rolled and beaten tow (STB 1195–2008)</i>			
Grab length, cm (V, %)	51,0 (9,0)	55,0 (9,6)	57,7 (5,6)
Flexibility, mm (V, %)	52,7 (4,0)	51,7 (7,3)	49,3 (6,2)
Breaking load, H (V, %)	215,7 (18,1)	223,0 (19,7)	235,0 (20,1)
Color, group	3	3	3
Fiber number	10,0	11,0	11,0

The content of organic matter of sod-podzolic medium loamy soil influenced the indices and average number of long flax rolled and beaten tow. Increase of the soil organic matter from 1.5 to 2.0–2.5% raised the fiber quality number from 10 to 11 due to increase of its grab length by 8–13% and breaking load by 3–9%.

The dependence of long flax rolled and beat-

en tow quality on soil organic matter content was described by linear regression equations, which prove its strong influence on the grab length ( $R^2 = 0,99$ ) and fiber strength ( $R^2 = 0,98$ ) (see the figure).

### CONCLUSION

Positive effect of soil organic matter on the

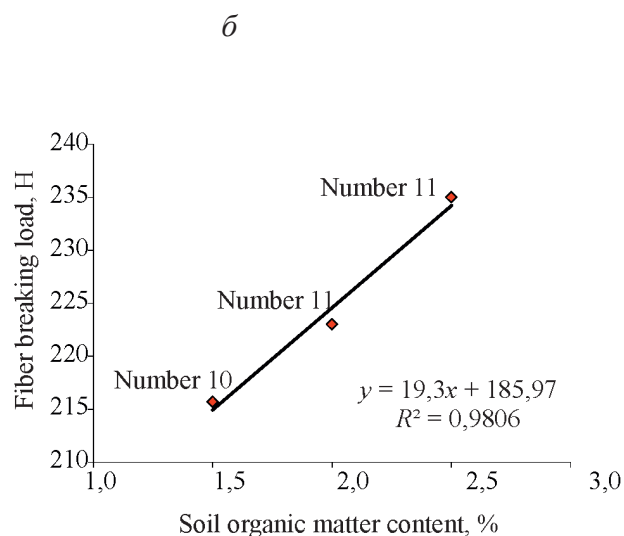
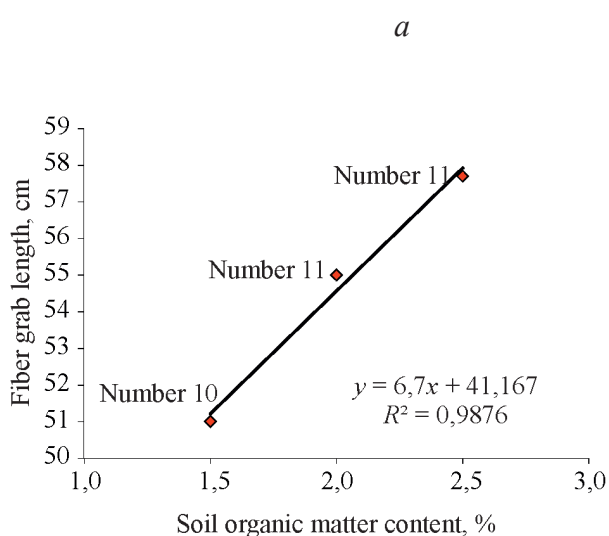

Влияние содержания органического вещества дерново-подзолистой почвы на горстевую длину (а), разрывную нагрузку (б) и номер длинного трепаного волокна (среднее за 2021–2023 гг.)

The influence of the organic matter content of soddy-podzolic soil on the strick of flax length (a), breaking load (б) and the number of long flax rolled and beaten tow (average for 2021–2023)

yield and quality of flax products has been proved. The increase in soil organic matter content from 1.5 to 2.0–2.5% boosted seed yield by 16–35% due to an increase in bolls (+22–39%) and seeds per plant (+46–65%), retted flax straw – by 10–33% due to an increase in technical stem length (+6–13%); fiber – by 14–37%, including long fiber – by 15–43% by increasing the number and size of bast bundles in the stem (+5–20 and 5–28%), as well as the number of elementary fibers in the bundle (+10–15%) and their transverse size (+7–10%). The quality of the retted flax straw has been improved by 1–2 numbers by increasing the content of long fiber fraction in it by 7–11% RH and improving the color by 16–21%. Increase in the quality of long flax rolled and beaten tow by 1 number is due to an increase in its grab length (+8–13%) and strength (+3–9%).

## СПИСОК ЛИТЕРАТУРЫ

1. Прудникова А.Г., Прудников А.Д., Богданова Л.И. Содержание гумуса в пахотных почвах Смоленской области и его трансформация под влиянием факторов интенсификации земледелия // *Агрохимический вестник*. 2023. № 3. С. 20–23. DOI: 10.24412/1029-2551-2023-3-005.
2. Hayes M.H.B., Swift R.S. Vindication of humic substances as a key component of organic matter in soil and water // *Advances in Agronomy*. 2020. Vol. 163. P. 1–37.
3. Швец Т.В., Поздеев И.А. Роль органического вещества в восстановлении плодородия почв на основе программы «умного» земледелия // *Тенденции развития науки и образования*. 2022. № 92-14. С. 145–150. DOI: 10.18411/trnio-12-2022-673.
4. Черногаев В.Г., Свирина В.А. Сравнительный анализ эффективности применения различных способов обработки почвы в системе ресурсосберегающих технологий земледелия // *Аграрная наука*. 2020. № 343 (11). С. 105–107. DOI: 10.32634/0869-8155-2020-343-11-105-107.
5. Байбеков Р.Ф., Хайдуков К.П., Коваленко А.А., Забугина Т.М. Качественный состав органического вещества дерново-подзолистой почвы в длительном полевом опы-

те // *Земледелие*. 2020. № 1. С. 8–11. DOI: 10.24411/0044-3913-2020-10102.

6. Богомолова Ю.А., Ивенин В.В., Ивенин А.В. Роль ресурсосберегающих технологий и деструкторов соломы в изменении содержания и качественного состава органического вещества светло-серой лесной почвы в условиях Нижегородской области // *Вестник Чувашского государственного аграрного университета*. 2023. № 4 (27). С. 13–19. DOI: 10.48612/vchfe5z-f7pk-uuab.
7. Серая Т.М., Богдевич И.М., Богатырева Е.Н., Станилевич И.С. Повышение запасов органического вещества в почвах пахотных земель республики Беларусь // *Почвоведение и агрохимия*. 2021. № 2 (67). С. 49–63.
8. Кирюшин В.И. Управление плодородием почв и продуктивностью агроценозов в адаптивно-ландшафтных системах земледелия // *Почвоведение*. 2019. № 9. С. 1130–1139. DOI: 10.1134/S0032180X19070062.
9. Перетрухин В.В., Домненкова А.В., Чернушевич Г.А., Босак В.Н. Роль органического вещества в повышении плодородия почвы и питании растений // *Главный агроном*. 2022. № 2. С. 8–12.
10. Балабанова Н.Ф., Воронкова Н.А., Дороненко В.Д., Цыганова Н.А. Содержание лабильного органического вещества в луговочерноземной почве при длительном применении удобрений // *Земледелие*. 2020. № 2. С. 7–9. DOI: 10.24411/0044-3913-2020-10202.
11. Dou S., Shan J., Song X. Are humic substances soil microbial residues or unique synthesized compounds? A perspective on their distinctiveness // *Pedosphere*. 2020. Vol. 30 (2). P. 159–167.

## REFERENCES

1. Prudnikova A.G., Prudnikov A.D., Bogdanova L.I. Humus content in arable soils of the Smolensk region and its transformation under influence of factors of agricultural intensification. *Agrokhimicheskii vestnik = Agrochemical Herald*, 2023, no. 3, pp. 20–23. (In Russian). DOI: 10.24412/1029-2551-2023-3-005.
2. Hayes M.H.B., Swift R.S. Vindication of humic substances as a key component of organic matter in soil and water. *Advances in Agronomy*, 2020, vol. 163, pp. 1–37.

3. Shvets T.V., Pozdeev I.A. The role of organic matter in restoring soil fertility based on the smart farming program. *Tendentsii razvitiya nauki i obrazovaniya = Trends in the development of science and education*, 2022, no. 92-14, pp. 145–150. (In Russian). DOI: 10.18411/trnio-12-2022-673.
4. Chernogaev V.G., Svirina V.A. Comparative analysis of the efficiency of application of different methods of tillage in the system of resource-saving agriculture technologies. *Agrarnaya nauka = Agrarian science*, 2020, no. 343 (11), pp. 105–107. (In Russian). DOI: 10.32634/0869-8155-2020-343-11-105-107.
5. Baibekov R.F., Khaidukov K.P., Kovalenko A.A., Zabugina T.M. Qualitative composition of organic matter of sod-podzolic soil in a long field experiment. *Zemledelie = Zemledelie*, 2020, no. 1, pp. 8–11. (In Russian). DOI: 10.24411/0044-3913-2020-10102.
6. Bogomolova Yu.A., Ivenin V.V., Ivenin A.V. The role of resource-saving technologies and straw destructors in changing the content and qualitative composition of organic matter of light gray forest soil in the Nizhny Novgorod region. *Vestnik Chuvashskogo gosudarstvennogo agrarnogo universiteta = Vestnik Chuvash State Agrarian University*, 2023, no. 4 (27), pp. 13–19. (In Russian). DOI: 10.48612/vchfe5z-f7pk-uuab.
7. Seraya T.M., Bogdevich I.M., Bogatyreva E.N., Stanilevich I.S. Increasing the stock of organic substance in soils agricultural lands of the Republic of Belarus. *Pochvovedenie i agrokhimiya = Soil Science and Agrochemistry*, 2021, no. 2 (67), pp. 49–63. (In Russian).
8. Kiryushin V.I. Management of soil fertility and productivity of agrocenoses in adaptive landscape farming systems. *Pochvovedenie = Eurasian Soil Science*, 2019, no. 9, pp. 1130–1139. (In Russian). DOI: 10.1134/S0032180X190762.
9. Peretrukhin V.V., Domnenkova A.V., Chernushkevich G.A., Bosak V.N. The role of organic matter in increasing soil fertility and plant nutrition. *Glavnyi agronom = Chief Agronomist*, 2022, no. 2, pp. 8–12. (In Russian).
10. Balabanova N.F., Voronkova N.A., Doronenko V.D., Tsyganova N.A. Content of labile organic matter in meadow-chernozem soil at prolonged application of fertilizers. *Zemledelie = Zemledelie*, 2020, no. 2, pp. 7–9. (In Russian). DOI: 10.24411/0044-3913-2020-10202.
11. Dou S., Shan J., Song X. Are humic substances soil microbial residues or unique synthesized compounds? A perspective on their distinctiveness. *Pedosphere*. 2020, vol. 30 (2), pp. 159–167.

#### ИНФОРМАЦИЯ ОБ АВТОРАХ

**Прудников В.А.**, доктор сельскохозяйственных наук, профессор, заведующий отделом

✉ **Степанова Н.В.**, кандидат сельскохозяйственных наук, ведущий научный сотрудник; **адрес для переписки:** Республика Беларусь, 211003, Витебская область, Агродорок Устье, ул. Центральная, 27; e-mail: Natali1673@mail.ru

**Фесько Д.Ю.**, научный сотрудник

#### AUTHOR INFORMATION

**Vladislav A. Prudnikov**, Doctor of Science in Agriculture, Professor, Department Head

✉ **Natalia V. Stepanova**, Candidate of Science in Agriculture, Lead Researcher; **address:** 27, Zentralnaya St., Ustye agro town, Vitebsk Region, 211003, Belarus; e-mail: Natali1673@mail.ru

**Dina Yu. Fesko**, Researcher

Дата поступления статьи / Received by the editors 04.06.2024  
Дата принятия к публикации / Accepted for publication 19.08.2024  
Дата публикации / Published 20.11.2024

## AUTHOR GUIDELINES

The guidelines are drawn up in accordance with the ethical principles, common for all the members of the scientific community, and the rules for publications in international and local scientific periodic magazines as well as in compliance with the requirements stipulated by the State Commission for Academic Degrees and Titles for the periodicals included in the List of Russian peer-reviewed scientific journals in which the major scientific outcomes of theses for the degrees of Doctor or Candidate of Sciences must be published.

The journal publishes original articles on fundamental and applied issues by the following directions:

- general agriculture and crop production;
- plant breeding, seed production and biotechnology;
- agrochemistry, soil science, plant protection and quarantine;
- fodder production;
- infectious diseases and animal immunology;
- private zootechnics, feeding, technology of feed preparation and production of livestock products;
- breeding, selection, genetics, and animal biotechnology;
- technologies, machinery and equipment for the agro-industrial complex;
- food systems.

The article sent to the editorial board must correspond to the thematic sections of the journal “Siberian Herald of Agricultural Science”:

Section name	Code and name of the scientific specialty in accordance with the Nomenclature of Scientific Specialties, for which academic degrees are awarded
Agriculture and chemicalization	4.1.1. General agriculture and crop production 4.1.3. Agrochemistry, soil science, plant protection and quarantine
Plant growing and breeding	4.1.1. General agriculture and crop production 4.1.2. Plant breeding, seed production and biotechnology
Plant protection	4.1.3. Agrochemistry, soil science, plant protection and quarantine
Fodder production	4.1.1. General agriculture and crop production 4.1.2. Plant breeding, seed production and biotechnology 4.1.3. Agrochemistry, soil science, plant protection and quarantine
Zootechnics and veterinary medicine	4.2.3. Infectious diseases and animal immunology 4.2.4. Private zootechnics, feeding, technology of feed preparation and production of livestock products 4.2.5. Breeding, selection, genetics, and animal biotechnology
Mechanization, automation, modelling and dataware	4.3.1. Technologies, machinery and equipment for the agro-industrial complex
Agriproducts processing	4.3.3. Food systems
Problems. Opinions Scientific relations From the history of agricultural science Brief reports From dissertations	4.1.1. General agriculture and crop production 4.1.2. Plant breeding, seed production and biotechnology 4.1.3. Agrochemistry, soil science, plant protection and quarantine 4.2.3. Infectious diseases and animal immunology 4.2.4. Private zootechnics, feeding, technology of feed preparation and production of livestock products 4.2.5. Breeding, selection, genetics, and animal biotechnology 4.3.1. Technologies, machinery and equipment for the agro-industrial complex 4.3.3. Food systems

## RECOMMENDATIONS TO THE AUTHOR BEFORE SUBMITTING AN ARTICLE

Submission of an article to the journal “Siberian Herald of Agricultural Science” implies that:

- an article has not been published before in any other journal;
- an article is not subject to review in any other journal;
- all co-authors agree with the publication of the current version of the article.

Before submitting an article, it is necessary to make sure that the file (files) contains all the information required in Russian and English, tables and figures provide the source of the information presented, all references are written correctly.

## PROCEDURE FOR SENDING MANUSCRIPTS OF ARTICLES

1 Submission of the article is carried out through the electronic editorial board on the journal's website <https://sibvest.elpub.ru/jour/index>. After preliminary registration of the author, choose the option "Send a manuscript" in the upper right corner of the page. Then download the manuscript (in \*.doc or \*.docx format) and the accompanying documents. When you have finished uploading, be sure to select the option "Send a Letter", in which case the editorial board will be automatically notified of the receipt of the new manuscript.

Accompanying documents to the manuscript of an article:

- a scanned copy of a letter from the organization confirming authorship and permission to publish (sample cover letter);
- a scanned copy of the author's note in the form provided (sample author's note), in which consent must be expressed for the open publication of the article in the printed version of the journal and its electronic copy in the Internet;
- a scanned copy of the manuscript with the authors' signatures. The author, by signing the manuscript and sending it to the editorial office, thereby transfers the copyright for the publication of this article to SFSCA RAS;
- author questionnaires in Russian and English (sample author questionnaire);
- a scanned copy of your post-graduate school transcript (for full-time postgraduate students).

2. All manuscripts received by the editorial board are registered via the electronic editorial system. The author's personal account shows the current status of the manuscript.

3. Non-reviewed materials (scientific chronicles, reviews, book reviews, materials on the history of agricultural science and activities of institutions and scientists) are sent to the e-mail: [sibvestnik@sfsca.ru](mailto:sibvestnik@sfsca.ru) and are registered by the executive secretary.

## ARTICLE DESIGN PROCEDURE

The text of the manuscript is printed in Times New Roman font, type size 14 with 1.5 spacing, all margins 2.0 cm, page numbering at the bottom. The size of a manuscript should not exceed 15 pages (including tables, illustrations and bibliography); the articles placed in the sections "From dissertations" and "Brief reports" should not exceed 7 pages.

Article design structure:

UDC

- 2. Title of an article in Russian and English (no more than 70 characters).
- 3. Surnames and initials of the authors, full official name of the scientific institution where the research was conducted in Russian and English.

If authors from different institutions took part in the preparation of the article, it is necessary to indicate the affiliation of each author to a particular institution using the superscript index.

4. Abstract in Russian and English. The size of the abstract should not be less than 200-250 words. The abstract is a brief and consistent presentation of the material of the article on the main sections and should reflect the main content, follow the logic of the presentation of the material and description of the results in the article with the provision of specific data. The abstract should not include the newly introduced terms, abbreviations (with the exception of common knowledge), references to the literature. The abstract should not emphasize the novelty, relevance and personal contribution of the author; the place of research should be indicated to the district (region), specific organizations should not be mentioned.

5. Keywords in Russian and English. There should be up to 5-7 words by the topic of the article. It is desirable that the keywords support the abstract and the title of the article.

6. Information on the conflict of interests or its absence. The author should notify the editor on the real or potential conflict of interests by including the information in the appropriate section of the article. If there is no conflict of interests, the author should also inform the editor about it.

Example wording: "The author declares no conflict of interest".

7. Acknowledgements in Russian and English. This section lists all sources of funding for the study, as well as acknowledgements to people who contributed to the article but are not the authors.

8. The main body of the article. When presenting original experimental data, it is recommended to use subheadings:

**INTRODUCTION** (problem statement, goal and tasks of the study)

**MATERIAL AND METHODS** (conditions, methods (methodology) of research, object description, place and time of research)

**RESULTS AND DISCUSSION**

**CONCLUSION**

**REFERENCES.** The number of sources must be at least 15. The list of references includes only peer-reviewed sources: articles from scientific journals and monographs. Self-citation of no more than 10% of the total number. The bibliography list should be designed as a general list in the order of mention in the text, it is desirable to refer to sources 2-3 years old. The rules for the list of references are in accordance with GOST R 7.05-2008 (requirements and rules for compiling a bibliographical reference). In the text the reference to the source is marked by a serial number in square brackets, for example [1]. Literature in the list is given in the languages in which it was published. In the bibliographic description of the publication, it is necessary to include all authors, without abbreviating them by one, three, etc. It is unacceptable to abbreviate the names of articles, journals, publishing houses.

1. If it is necessary to refer to abstracts, dissertations, collections of articles, textbooks, recommendations, manuals, GOSTs, information from websites, statistical reports, articles in socio-political newspapers, etc., such information should be placed in a footnote at the end of the page. Footnotes are numbered in Arabic numerals and placed page by page through continuous page numbering.

**Attention!** Theoretical, review and problem articles can have any structure, but must contain an abstract, keywords, list of references.

#### **EXAMPLE OF REFERENCES in Russian and English and FOOTNOTES**

##### **REFERENCES (in Russian):**

###### **Monograph**

*Klimova E.V.* Field crops of Zabaikalya: monograph. Chita: Poisk, 2001. 392 p.

###### **Part of a book**

*Kholmov V.G.* Minimum tillage of coulisse-strip fallow for spring wheat with intensification of arable agriculture in southern forest-steppe of Western Siberia // Resource-saving tillage systems. Moscow: Agropromizdat, 1990. pp. 230-235.

###### **Periodical publication**

*Pakul A.L., Lapshinov N.A., Bozhanova G.V., Pakul V.N.* Technological grain qualities of spring common wheat depending on the system of soil tillage // Siberian Herald of Agricultural Science. 2018. vol. 48. № 4. pp. 27-35. DOI: 10.26898/0370-8799-2018-4-4.

##### **REFERENCES (in English):**

References are compiled in the same order as the Russian version, according to the following rules:

Names and surnames of the authors are given in the established way of transliteration, English title of the article, transliteration of the name of the Russian-language source (for example through the site: <https://antropophob.ru/translit-bis/>) = English title of the source. The order of presentation for a monograph is the following: city, English name of the publisher, year, number of pages; for a journal: year, volume, number, pages. (In Russian).

**Example:** Author A.A., Author B.B., Author C.C. Title of article.

Transliteration of the authors. English title of the article.

Zaglavie jurnala = Title of Journal, 2012, vol. 10, no. 2, pp. 49–54.

Transliteration of the source = English name of the source

###### **Monograph**

*Klimova E.V.* Field crops of Zabaikalya. Chita, Poisk Publ., 2001, 392 p. (In Russian).

###### **Part of a book**

*Kholmov V.G.* Minimum tillage of coulisse-strip fallow for spring wheat with intensification of arable agriculture in southern forest-steppe of Western Siberia. *Resource-saving tillage systems*, Moscow, Agropromizdat Publ., 1990, pp. 230–235. (In Russian).

###### **Periodical publication**

*Pakul A.L., Lapshinov N.A., Bozhanova G.V., Pakul V.N.* Technological grain qualities of spring common wheat depending on the system of soil tillage. *Sibirskii vestnik sel'skokhozyaistvennoi nauki = Siberian Herald of Agricultural Science*, 2018, vol. 48, no. 4, pp. 27–35. (In Russian). DOI: 10.26898/0370-8799-2018-4-4.

##### **FOOTNOTES:**

Quoted text<sub>1</sub>.

<sup>1</sup>*Klimova E.V., Andreeva O.T., Temnikova G.P.* Ways to stabilize food production in Transbaikalia // Problems and prospects of perfecting zonal farming systems in modern conditions: materials of the scientific and practical conf. (Chita, October 16-17 2008). Chita, 2009, pp.36-39.

**Digital Object Identifier – DOI** (when the cited material has it) should be indicated at the end of the bibliographic reference.

Example:

*Chu T., Starek M.J., Brewer M.J., Murray S.C., Pruter L.S.* Assessing lodging severity over an experimental maize (*Zea mays* L.) field using UAS images // Remote Sensing. 2017. Vol. 9. P. 923. DOI: 10.3390/rs9090923.

The DOI of the article should be checked on the website <http://search.crossref.org/> or <https://www.citethisforme.com>. To do this, enter the title of the article in English in the search bar.

## **FIGURES, GRAPHS, TABLES, SCREENSHOTS, PHOTOGRAPHS AND FORMULAS**

The figures must be of good quality, suitable for printing. All figures must have captions. The caption must be translated into English. Figures should be numbered in Arabic numerals according to the order in the text. If there is only one figure in the text, it is not numbered. References to figures should be formatted as follows: “Fig. 3 indicates that ...” or “It is indicated that ... (see Fig. 3)”. The caption under the figure includes a figure number and its title. “Figure 2. Description of vital processes.” The translation of the figure caption should be placed after the figure caption in Russian.

Tables should be of good quality, suitable for printing. Tables suitable for editing are preferred, not scanned or as figures. All tables should have headings. The title of the table should be translated into English. Tables should be numbered in Arabic numerals according to the order in the text. If there is only one table in the text, it is not numbered.

References to tables should be formatted as follows: “Table 3 states that ...” or “It is stated that ... (see Table 3)”. The title of the table includes a table number and its title: “Table 2. Description of Vital Processes.” The translation of the table title should be placed after the table title in Russian.

Photos, screenshots must be uploaded separately as files of the following format\*.jpeg files (\*.doc and \*.docx if the image has additional marks). The resolution of the image should be >300 dpi. The image files should be given a name corresponding to the figure number in the text. In the description of the file a caption should be given separately, which should correspond to the name of the picture placed in the text.

Graphs, charts, histograms, etc. should be attached as a separate file in Microsoft Excel program.

Attention should be paid to the spelling of formulas in the article. All formulas must be editable, i.e. it must be possible to make changes to them. To avoid confusion, it is necessary to write Greek ( $\alpha$ ,  $\beta$ ,  $\pi$ , etc.), Russian (A, a, B, b, etc.) letters and numbers in straight font, Latin letters in italics (*W*, *Z*, *m*, *n*, etc.). Mathematical signs and symbols should also be written in straight font. It is necessary to clearly indicate upper and lower superscript characters ( $W_1$ ,  $F_1$ , etc.).

## **INTERACTION BETWEEN THE JOURNAL AND THE AUTHOR**

The Editorial Board asks the authors to be guided by the above stated rules when preparing the article.

All the articles submitted to “Siberian Herald of Agricultural Science” go through preliminary check for compliance with formal requirements. At this stage the Editorial Board reserves the right to:

- accept the article for review;
- return the article to the author (authors) for revision with a request to correct the mistakes or add the missing data;
- return the article which is designed not according to the journal’s requirements to the author (authors) without consideration;

- reject the article due to its inconsistency to the journal’s goals, lack of originality and little scientific significance.

Correspondence with the authors of the manuscript is maintained through a key contact mentioned in the manuscript.

All scientific articles submitted to the editorial board of the journal “Siberian Herald of Agricultural Science” undergo obligatory double-blind reviewing (author and reviewer do not know about each other). Manuscripts are sent in accordance with their research profile for reviewing to the members of the Editorial Board.

In controversial cases, the editor may involve several specialists in the review process, as well as the Editor-in-Chief. If the reviewer’s opinion is positive, the article is submitted to the editor for preparation for publication.

In case a decision is made to have the manuscript revised, reviewer’s comments and remarks are passed to the author. The latter is given two months to make amendments. If, within this period, the author has not notified the editors about the actions planned, the article is removed from the publication waiting list.

In case there is a decision to reject the article, the notification with the editorial decision is sent to the author.

The designated author (contact author) is sent the final version of the manuscript accepted for publication, which he/she must check.

## **REVERSAL OF EDITOR/ REVIEWER’S DECISION**

In case the author does not agree with the conclusions of the reviewer and/or editor, they can dispute the decision made. In order to do this, the author should:

- amend the manuscript in compliance with the comments substantiated by reviewers and editors;
- clearly outline their stance on the issue under question.

The editors facilitate the second submission of manuscripts that could potentially be accepted but were rejected due to the need of significant amendments or collection of the additional data, and are ready to clearly explain what must be rectified in the manuscript for it to be accepted for publication.

## **ACTIONS OF THE EDITORIAL BOARD IN CASE OF PLAGIARISM AND DATA FALSIFICATION DETECTION**

The Editorial Board of the “Siberian Herald of Agricultural Science” follows the conventional ethical principles for scientific periodicals and guidelines of the “Publication Ethics Code” developed and approved of by the Committee on Publication Ethics (COPE) and demands that all those involved in the publishing process should obey these principles.

## **ERRORS RECTIFICATION AND ARTICLE WITHDRAWAL**

In case of error detection that affect understanding of an article but do not distort the results of research, they can be rectified by replacing the pdf-file of an article. In case of error detection that distort the results of research or in case of plagiarism or misconduct of the author (authors) connected with data falsification, the article can be withdrawn. The withdrawal can be initiated by the editors, the author, organization or private individual. Such article is marked with the note “Article withdrawn”, the page of the article gives the reason for withdrawal. Information about the article withdrawal is sent to data bases where the journal is indexed.

## ***УВАЖАЕМЫЕ ПОДПИСЧИКИ!***

Подписку на журнал «Сибирский вестник сельскохозяйственной науки»  
(как на годовой комплект, так и на отдельные номера)  
можно оформить одним из следующих способов:

**В агентстве подписки ООО «Урал-Пресс»  
подписной индекс 014973**

Ссылка на издание <https://www.ural-press.ru/search/?q=014973>.

В разделе контакты зайти по ссылке  
<http://ural-press.ru/contact/>, где можно выбрать филиал по месту жительства

---

**В редакции журнала**

тел. 7 (383) 348-37-62, e-mail: [sibvestnik@sfscsca.ru](mailto:sibvestnik@sfscsca.ru)

---

Полнотекстовая версия журнала  
«Сибирский вестник сельскохозяйственной науки»  
размещена на сайте Научной электронной библиотеки:  
<http://www.elibrary.ru>.